



## **HIGH PRESSURE WATER JETTING IN THE OIL AND GAS INDUSTRY**

# OIL AND GAS INDUSTRY

## RELIABLE CLEANING UNDER EXTREME CONDITIONS



Underlying the refineries and off-shore platforms for both the extraction and processing of oil and gas are the strongest operational safety standards. In order to guarantee a secure and simultaneously effective service, the production, storage and transport facilities must be regularly inspected, cleaned, serviced and possibly repaired. The exterior conditions in this regard are often extreme.

Due to the dimensions and the materials used, typical tasks include cleaning, de-coating and derusting, as well as cutting and separating. Therefore, the most varied procedures and devices come into use, which require considerable effort and expense. As the single suitable solution for all of these tasks, high pressure water jetting is becoming more and more common. As a blasting

and cutting tool, water is both safety-conscious as well as environmentally harmless. For this method, the proven WOMA® plunger pumps, as well as a complete range of units and tools specifically developed for the highest of pressure, are available.

01

### General Surface Cleaning

Various different surfaces and materials must be cleaned regularly in order to guarantee continuous work processes and safety during operation.

02

### Sieve and Filter Cleaning

For sieves and filters, the ability to function depends largely on the condition of their surfaces. Therefore, they must be constantly cleaned.



03

### Heat Exchanger Cleaning

Stubborn deposits often build up in heat exchangers. Clean surfaces are the basis of efficient production processes here.

04

### Tank Cleaning

A quick and thorough cleaning of tanks is necessary in order to disrupt the production process as little as possible.

05

### Pipe Cleaning

Pipes have important functions across the industry. In order to fulfil these functions, their consistency must be ensured.

06

### Cleaning and Maintenance Off-Shore

Differing materials must be cleaned, derusted, decoated and cut under the most extreme conditions and in the narrowest of spaces.

# GENERAL SURFACE CLEANING

In the processing and manufacturing industry, regular cleaning work and maintenance is essential in order to guarantee continuous work processes and operational safety. The cleaning of surfaces entails vastly differing requirements. Therefore, typical and frequent tasks include:

- General cleaning work such as the cleaning of machine parts, procedural components, transport containers, valves, etc.
- Cleaning of technical installations and surfaces that influence the production process
- Removal of coating and painting on buildings and technical devices
- De-rusting of steel surfaces
- Removal of burned materials, e.g. due to high process temperatures or welding work

The use of water to clean under high pressure is suitable for a wide variety of surfaces and materials. In combination with innovative accessories, a high work efficiency with a simultaneously high safety level is achieved by the user.

Insoluble substances such as oil, dispersion or mineral colours, as well as stubborn deposits, can be broken down, dissolved, and removed using high water pressure. Because water gets into practically every small



**01** With the WOMA® FloorMaster, large floor spaces can be cleaned quickly and safely.

**02** The removal of erosion and cleaning of every kind is possible with help from the high water pressure gun.

**03** Rubber and other stubborn coatings can be removed.

space, sharp-edged surfaces and flanges do not need to be cleaned afterwards. Water pressure cleaning does not develop dust exposure and eliminates the need for the sourcing and disposal of blasting abrasives. The related burden of this for users, surfaces and the environment is consequently avoided. Because only clean water is used, removed substances can easily be filtered out. Neither collection tanks, nor acids, lyes or any other solvents, which must be disposed of, need to be used. The materials used, quantities of waste and costs are greatly reduced as a consequence of this.

For water jetting procedures with ultra high pressure, correspondingly strict legal safety standards apply. Innovative product developments provide the possibility of working far away from the lance and reduce the risk for the user. Parallel to this, modern, lighter protective equipment offers a greater range of movement during work.

The high pressure water technique is designed for use in EX-areas, as no flying sparks occur. With regard to cleaning parts in areas with a threat of explosion, these need not be dismantled, but can be cleaned directly on-site.

#### Advantages at a glance

- High pressure water jetting can be used for the cleaning of various surfaces and materials
- The smallest of cracks, corners and any unevenness can be reached
- No additional subsequent cleaning is required

### WOMA® INNOVATION: SAFE PARTS CLEANING

With the mobile parts cleaning device MCS Safety, WOMA® revolutionises parts cleaning in terms of safety and efficiency by using high pressure water jetting. With this system, personnel and work pieces are separated using a mobile safety wall. On one side, the part to be cleaned is fixed onto a movable table, which can be operated by a steering wheel. The water tool is mounted on a telescopic lance and can be steered from the other side of the safety wall. The operator is always outside of the danger area and does not need to wear any protective equipment for using high pressure.



# SIEVE AND FILTER CLEANING

In almost all sectors of industry, sieves and filters, as well as their baskets, trays and nets come into use. The ability of these important procedural components to function depends substantially on the condition of their surface. Consequently, sieves and filters must be cleaned on a regular basis.

High pressure water jetting is often used for diverse cleaning work in sieves and filters:

- Removal of incrustation and dirt from sieves and filters
- Cleaning of plastic, long and round sieves
- Cleaning of filter cloth, viscose filters, cartridge filters or wet felts
- Descaling of suction strainers
- Removals of dirt from drainage and filter press
- Removal of residue from steel trays



**01\_WOMA®** offers many water tools for the thorough cleaning of sieves and filters.

High pressure water jetting guarantees an extremely gentle removal of dirt and deposits without damaging the filter and carrier material. Completely free of chemical or abrasive contents. The development of gases, cinders, and steam is consequently avoided, in contrast to chemical cleaning. Cleaning with high pressure water is a particularly flexible and sustainable method, where deposits, caking, coating, plating, incrustation, oxide layers, slurries and calcification can be removed from sieves and filters in a reliable way.

WOMA® offers a wide range of tools and accessories for the most varying geometrics and dirt from sieves and filters. By using these, very good cleaning results can be achieved even in difficult to access, narrow,

or contaminated areas. Cleaning can often be done even during operation or upon fixed machines, without the need to dismantle the installation. Automated cleaning tools remove the need for manual, dirty and unhygienic work whilst promoting safe and continuous work.

#### Advantages at a glance

- Careful and reliable removal of dirt
- Avoidance of cinders, gases and steam
- Reliable cleaning also in hard-to-reach areas, during operation or within fixed installations



**01** The cleaning of very dirty filter baskets is no problem using high pressure water jetting.

**02** WOMA® offers a suitable solution even for small diameters and hard-to-access sieves and filters.

**03** A smooth production process is not guaranteed with a very dirty filter.

**04** After cleaning, the filter is again usable.



# HEAT EXCHANGER CLEANING

The thermal exchange process in heat exchangers often leads to a build up of stubborn deposits, which can harden and reduce flow, or even completely block the apparatus. Clean surfaces and unhindered material flow are, however, the basis for efficient production processes, which are required for constant production temperatures.

Through a regular and residue-free cleaning process for the heat exchangers, process efficiency can be improved, and energy can be simultaneously saved. Technical requirements and local conditions can be very different and are already consistently taken into consideration during the planning for the cleaning:

- Large total surface areas that are hard to clean, with partly complicated geometric build, such as U-shaped pipes or narrow pipes with just a 12 mm diameter
- Various deposits with often extremely hard top layers
- In some cases, both internal and external cleaning is necessary

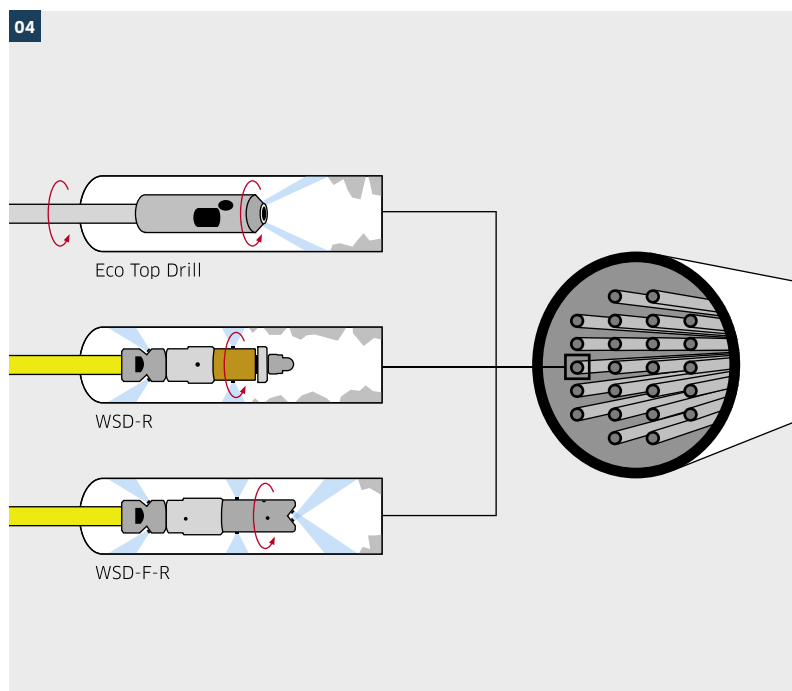
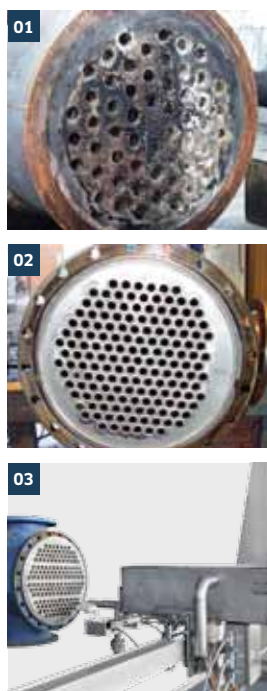

- 01** Stubborn deposits in heat exchangers can completely block production lines.
- 02** Clean surfaces are the basis for efficient production processes.
- 03** Optimal for danger zones: Remote controlled system by WOMA® for cleaning of tube bundles.
- 04** The accessory programme from WOMA® offers diverse water tools for the cleaning of heat exchangers.



- Often it is not possible to clean the heat exchanger on site, because there is too little space or no access. Then, the heat exchanger must be dismantled and transported to a washing area
- The cleaning tasks must be completed as soon as possible so that production can continue
- Liquid mediums often contain dirt and fixed components, for example, carbonate, minerals, oxide, burned chemicals or deposits from oil and sulphite

Every cleaning method has systemic pros and cons. High pressure water jetting, on the other hand, is usable universally for internal and external cleaning, varying surfaces, mediums and coatings. In comparison, other cleaning processes have considerable disadvantages in part, namely usability, cleaning results and cost.

Chemical washing in acid baths is very complicated and requires large tubs. Cleaning with ultrasound is very time-consuming and does not reach deep crevices well. Sand-blasting is abrasive and linked to high material and disposal costs. Mechanical drilling is complex and only suitable for straight pipes.

#### Advantages at a glance

- Universally usable cleaning method for the internal and external cleaning of heat exchangers
- Heat exchangers with particularly complex geometrics and particularly small pipes can be reliably cleaned
- Work in areas with threat of explosion is possible

## EXPERTISE PLATE HEAT EXCHANGERS

Plate heat exchangers often consist of plates with a wide surface area. These must be deconstructed in order to be cleaned, and every plate must be cleaned on both sides. These surfaces are a considerable challenge to clean. Regular surface cleaning with UHP devices and work tools targets perfect results every time.

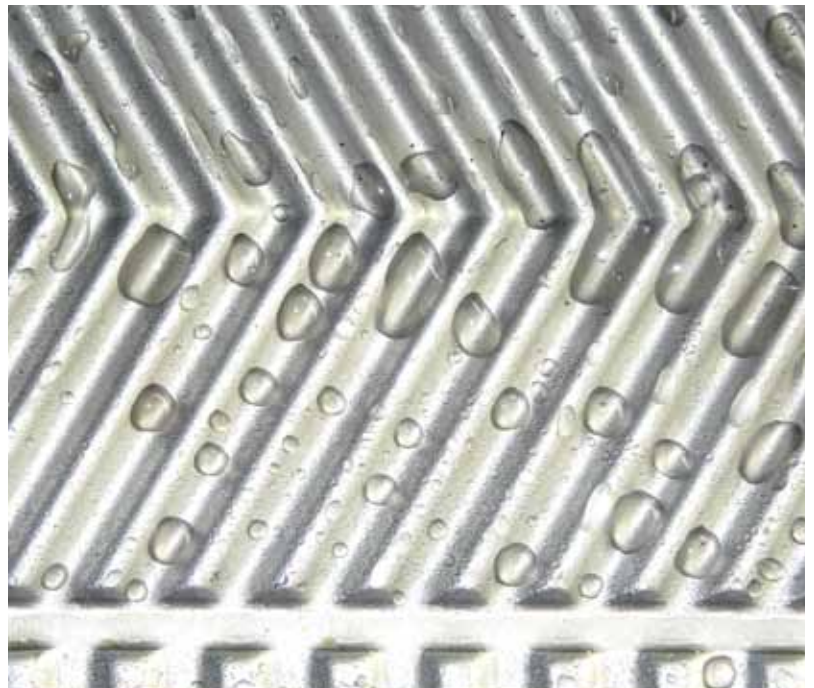

# TANK CLEANING

Internal cleaning is the main point of tank maintenance. In order to disrupt the production process as little as possible, a quick and thorough cleaning of storage tanks, reactor tanks etc. is crucial. The external cleaning of tanks occurs primarily for avoiding corrosion or for visual reasons.

The large number of varying tank designs is a challenge for internal cleaning: size, diameter, material, facing horizontally or vertically, number, position and size of the opening, build and size of the stirring unit. The prominent cleaning processes are time-consuming due to required personal protective equipment, often in addition to respiratory protection. In very large tanks, not all places can be reached by hand. The modern answer to all questions regarding internal cleaning of tanks is the WOMA® TankMaster.

Tank washing heads are high pressure water tools with a self-propelling rotor, which is driven using the reactive power of the escaping water jets. The rotor speed is dependant on the volume flow as well as the operating pressure and is regulated through a simple-to-operate magnetic brake.

Depending on the power, tank washing heads can be used without extension arms for tanks up to 6 m wide. Using extension arms, tank diameters of 12–15 m are pos-

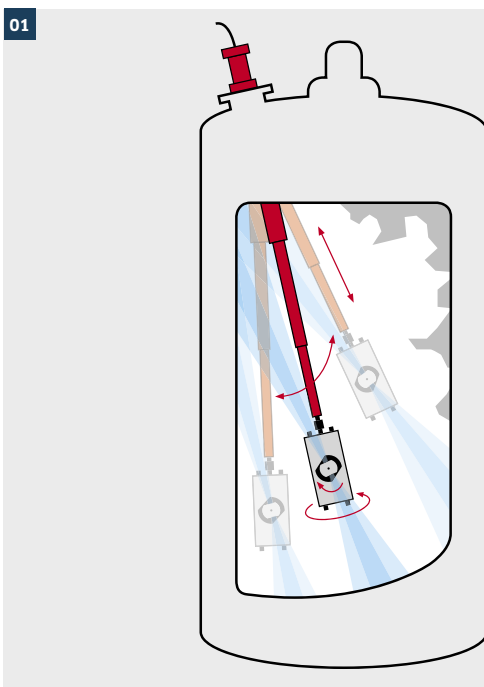

**01** For the safe and thorough internal cleaning of tanks, the TankMaster can be placed with a positioning device.

**02** For the manual cleaning of tanks, WOMA® offers a wide portfolio of high pressure guns.

**03** WOMA® water tools are also suitable for the cleaning of tanks for transportation and tankers containing dangerous goods.

sible. In tanks with a diameter of more than 15 m, the tank washing heads must be used with a positioning device or a decentralised service opening in the tank. More tank washing heads can be brought into use in tanks that are constructed in a horizontal direction or which have more openings: hanging free in the container or with help from a positioning device, which places the TankMaster onto all points in the container.

For optimal cleaning results and minimal cleaning time, a dense jetting image of the tank cleaning head and its optimal positioning in the tank – without shadow – is necessary. Due to ATEX certification of the tank washing heads and the positioning device, the TankMaster is also an efficient and economical solution for tankers transporting dangerous goods and tanks located in areas where there is a risk of explosion.

The TankMaster fulfils the requirements of users and service contractors:

- It can be lifted by one person and carried into all established container openings
- Universally usable through small dimensions and a light weight
- Robust construction for rough everyday operation

The efficient solution for external cleaning of steel tanks is the Magnet Lizard. This high pressure water tool with up to 2500 bar pressure quickly, thoroughly and reliably removes deposits of all kinds. The Magnet Lizard, with permanent magnets and chain drive, moves horizontally or vertically on the external wall – to a great height – and spares the user from time and cost intensive scaffolding to revise or dismantle.

#### Advantages at a glance

- Safe and fast cleaning for tanks of all sizes
- Robust tank washing heads with a light weight and very good jetting image
- ATEX certified products for cleaning of tanks transporting dangerous goods and those in explosion-risk areas

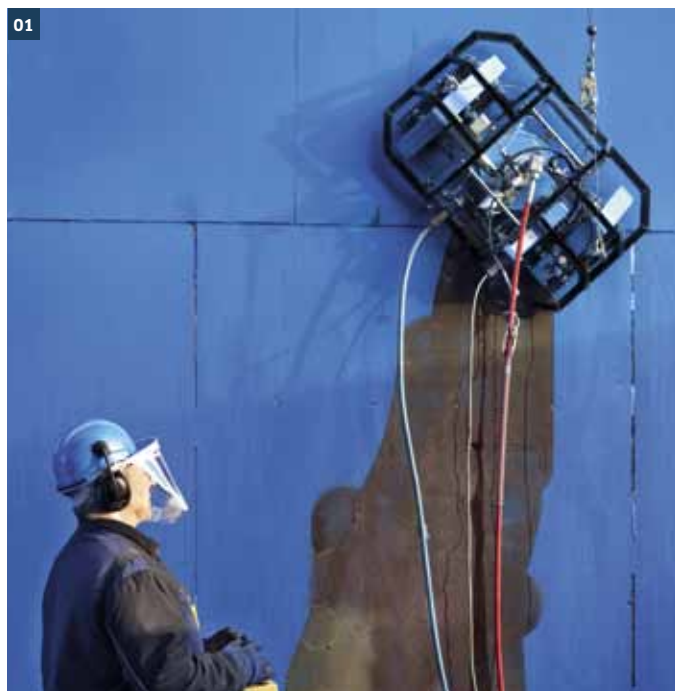

**01** The WOMA® Magnet Lizard is the optimal work tool for external cleaning and paint removal from large surfaces.

**02** WOMA® water tools cover the entire width of tank cleaning.

**03** Easy-to-reach places can be cleaned with a high pressure gun.

# PIPE CLEANING

Pipes are the lifeline of all facilities in every sector of industry: From pipes with 12 mm internal width to big pipelines, for fluids, solid materials or gases, with vacuums, overpressure or in a constant flow of flux. In order for pipes to fulfil their important functions, their continuity must be guaranteed.

All kinds of pipes and sewers must be kept clear, and this is important for a number of reasons. The material flow must be able to circulate unhindered, otherwise, it can lead to disruptions in the production process. Professional pipe cleaning is the requirement for meaningful inspections, filling and pressure tests as well as preparation for repairs. High pressure water jetting can be used for the washing and cleaning of pipes, internally and externally, as well as cutting pipes.

There are infinitely many different pipes and haulings. The corresponding cleaning methods are just as different. Large lengths and widths all add up to large surfaces. In addition, there are a multitude of different materials, bends and valves.

Particularly challenging are the hard deposits that can completely block pipes: sand, stone and organic material, for example, roots. Mediums such as crude oil, diesel or gas can be most problematic. Crude oil



**01** Dirty pipes can be a reason for disruptions in production process.

**02** Clean pipes are required for unhindered, freeflowing production materials.

**03** WOMA® offers high pressure units and accessories to clean pipes of all widths.

contains accompanying substances such as limestone, sulphite, salt etc., which cause stubborn deposits and can completely block pipes. In all of these cases, production can come to a standstill. When the going inside pipes gets tough, the water must get even tougher. As tough as ultra-high pressure. High pressure is the optimal solution for all time-sensitive cleaning tasks regarding dirty, blocked or corroded pipes.

Different jets can be adapted to clean the pipes, which means that deposits and severe blockages can be removed. In many cases, pipelines are fixed in place and offer only a few openings for access. In this case, cleaning with high water pressure is possible on site, without the need to deconstruct the pipe, particularly in hard-to-access facilities, whether it is due to high-up places, or narrow areas.

In contrast to mechanical tools such as hammers, chisels and brushes, there is no danger of damage during cleaning. The high pressure water jet technology is a quick, simple and extremely cost-effective procedure. Using water as a cleaning medium is simple to recycle using a filter.

With pipes with very large diameters, for example, water pressure pipes from hydro-electric power plants, pipelines and sewer pipes, which need to be cleaned over a long stretch, a lot of power is required. The WOMA® high pressure water technique is also the leader when it comes to such tasks, where other procedures have limits, or have exceeded their limits.

#### Advantages at a glance

- The cleaning of pipes is feasible, even in hard-to-access areas
- Pipes with differing widths can be freed from dirt and deposits
- Water jetting causes no damages to the inner walls of the pipes

## EXPERTISE PIPE CUTTING

Pipes are not just cleaned, but are also cut, for example, to repair damages, replace sections, build connections or when tearing down facilities. Cold cutting with help from abrasives at 2000–3000 bar pressure is the most versatile and economical solution. Pipes of all wall thicknesses can be cut. This procedure is spark-free and can also be used on areas at risk of explosion.



# CLEANING AND MAINTENANCE OFFSHORE

There are hardly any more extreme working fields than offshore. The external conditions on the high seas pose challenges for both people and materials. More extensive technology is assembled in the tiniest space. With kilometer-long drill pipes, aggressive environmental influences as well as round-the-clock operations, every unplanned interruption costs a lot of money.

Typical operations on offshore platforms are cleaning, layering and derusting, as well as the cutting and separation of surfaces and materials of every different type and dimension.

- Cleaning of pipes and pipe systems
- Removal of algae and deposits, lacquer and coating on the outer walls
- Removal of rust and coating of ballast tanks and storage areas
- Cutting of steel, other metals and a number of other materials
- Underwater cleaning to remove mussel growths, etc.
- Cleaning of drilling tools and drill pipes
- General cleaning of the platform of oil, grease, dust, rust and other dirt



**01** Work carried out on offshore platforms occurs under the most extreme conditions.

**02** Due to the rough environment, platforms must be cleaned, derusted and sanitised every day.

**03** WOMA® offers the right products for underwater maintenance work.

WOMA® provides high pressure water jet technology specifically for offshore use with crucial advantages. The logistics are noticeably reduced. Transport and disposal of blasting abrasives are omitted. The percentage of disposable residue is reduced to 98%. Desalted water is available on the platforms anyway. The salt content of processed areas is minimised, as the high pressure jetting itself gets into the smallest of cracks. Blasting abrasives, in contrast, often release the salt into the surface. High pressure water jetting cleans particularly thoroughly and produces an excellent adhesive foundation for new coats. Sensitive parts such as welding seams or connecting elements are not damaged. The work progress in comparison to mechanical brushes is even considerably quicker.

High pressure water jetting is high precision: prescribed rust removal can be done without any problems. Compact work tool dimensions enable the work to be completed in difficult-to-access and narrow areas. With help from mechanical guiding devices, geometrically exact removal can be done without difficulty. It is also possible to remove multi-layered systems. Every for-

mation of dust is excluded. This enables a simultaneous process of more tasks, for example, dust-sensitive maintenance work in parallel to foundation preparation.

### Advantages at a glance

With high pressure water jetting, the following materials can be reliably cleaned from metal and concrete surfaces:

- Bonded, multilayer coatings and layers of paint
- Flameproof coatings
- Bitumen
- Chemical contamination
- Rubber, rosin, lacquer
- Oil, rust, dirt
- Marine growth

With abrasive high pressure water jetting devices, the following materials and components can be cut:

- Construction steel
- Coated steel constructions
- Tanks, pipes and pipelines
- Strongly reinforced concrete
- Fibre-reinforced materials
- Multiple layer constructions
- Glass and ceramic

## EXPERTISE DRILL PIPES

Millions of pipes for drilling of gas and oil are in use worldwide. The investment and functionality of this expensive equipment can be ensured through continuous cleaning. In operation, drill pipes can regularly become partially or completely blocked and corroded due to aggressive mediums. Sulphate, salt and cinders are particularly problematic in this respect. The internal and external cleaning of dirty, corroded drill pipes with high pressure water jetting removes all deposits reliably, quickly and above all, economically.





# WOMA® PRODUCT PORTFOLIO

Ultra-high pressure is a challenging technique that only a few master. Here at WOMA®, we have over 50 years of intensive experience in cleaning, removal and cutting with high pressure.





At the centre of every WOMA® ultra-high pressure device is the pump. Powered through particularly powerful and reliable electronic motors or diesel engines, WOMA® pumps generate enormous pressure of up to 4000 bar. A permanent, technological challenge, which we meet consistently with passion for technology and the highest

standards of quality. Our in-house production level of 80% emphasises our demand for quality, high performance and availability without compromise. A standard that customers all over the world trust. A standard that we guarantee with professional service. Worldwide.

	General Surface Cleaning	Sieve and Filter Cleaning
		
<b>Recommended WOMA® High pressure units</b>	EcoRunner 250Z EcoMaster MK3 EcoMaster D 1502 Classic EcoMaster D 250Z Classic EcoTherm 800 EcoCold 500/30 Classic	EcoRunner 250Z EcoMaster D 1502 Classic EcoMaster D 250Z Classic EcoTherm 800
<b>Recommended WOMA® Water tools</b>	High pressure guns Turbo Nozzle TD3000-SCS Eco Top Rotating Cleaner FloorMaster VacuJet MCS Safety	High pressure guns Turbo Nozzle TD3000-SCS Orbimaster Speedy TubeMaster





Heat Exchanger Cleaning	Tank Cleaning	Pipe Cleaning	Cleaning and Maintenance Offshore
			
<p>EcoRunner 250M EcoMaster MK3 EcoMaster D 250M Classic EcoMaster D 250Z Classic</p>	<p>EcoRunner 250Z EcoMaster D 250Z Classic EcoMaster D 150Z Classic EcoMaster D 1502 Classic</p>	<p>EcoRunner 250Z EcoMaster D 250Z Classic EcoMaster D 1502 Classic EcoTherm 800 EcoCold 500/30 Classic</p>	<p>EcoMaster Offshore</p>
<p>Pipe Cleaning Nozzles Whirl Jet Nozzles Eco Top Drill PreventMaster FlexlanceMaster TBS Expert</p>	<p>High pressure guns TankMaster Telescopic device TV5000 EX Positioning device PV5000/12000</p>	<p>Pipe Cleaning Nozzles Whirl Jet Nozzles TubeMaster</p>	<p>High pressure guns Underwater guns EcoTop Cutter Pipe Cleaning Nozzles Whirl Jet Nozzles TubeMaster</p>

# WATER AS A TOOL



The power of water has been used by people since ancient times. Water power has propelled mills and lifted heavy loads. Water power is an important re-generating energy source. However, water can be much more. The revolutionary idea of using the mechanical effects of flowing water for cleaning with enormous pressure formed the foundations of WOMA® in 1962. Since then, this idea has become the driving force across businesses.

WOMA®'s first innovated product - the ATÜLAG, a high pressure cleaner for Sewage cleaning - revolutionised the industry of that time. Since then, WOMA® has become one of the leading manufacturers of high pressure pumps, high pressure units and accessories.

Consequent research and development allowed us to master systems using water pressure up to 4000 bar. In order to better understand how enormously high this pressure is, it equals four times the water pressure at the deepest point of the ocean. In the Mariana Trench, this is up to 10000 m deep. Humans have been to this region of highest pressure only once. WOMA® customers work with this pressure every day.

WOMA® has delivered high pressure technology to customers across the world for over 50 years. As part of the Kärcher group, we have reached through the international

distributor and service network of the market leader in cleaning techniques, a growing international target market.



**01** WOMA® has produced high pressure pumps and units for more than 50 years.

**02** WOMA®'s first successful product is the WOMA® ATÜLAG.

**03** Still today, WOMA® products are being constructed and assembled in Duisburg.

**04** WOMA® has mastered pumps and systems of up to 4000 bar.

**05** Since its formation in 1962, WOMA® has been operating from its office in Duisburg and from here, delivers to customers all over the world.



# CONTACT AND SUPPORT

## **WOMA GmbH**

Werthausen Straße 77 - 79  
47226 Duisburg

P.O. Box 14 18 20  
47208 Duisburg

Phone +49 2065 304-0  
Fax +49 2065 304-200

Email [info@woma.de](mailto:info@woma.de)  
Web [www.woma.de](http://www.woma.de)