

KÄRCHER

makes a difference



THE INDUSTRY SPECIALISTS.

Robust. Versatile. Fully hydraulic.

Totally efficient. Endurance meets economy.

A new class of ride-on sweepers has arrived for industrial use. With an environmental friendly Lpg drive, robust steel chassis, impact-protected side brushes and fully hydraulic operation of all functional units. Rigorously designed for efficiency and reliability, with high-quality components. Drive performance, filter and sweeping performance, load capacity and design - these sweepers are in a class of their own. With the exemplary ergonomics and ease of use you expect from Kärcher. The KM 130/300 R and KM 150/500 R gives contract cleaners, industry, logistics and municipalities exactly what they need. Both models can be equipped to tackle the demands of practically any cleaning job.

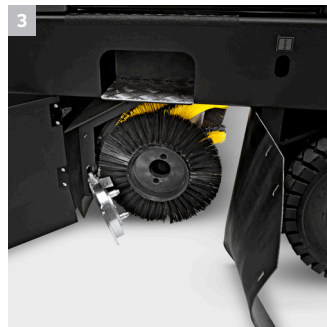
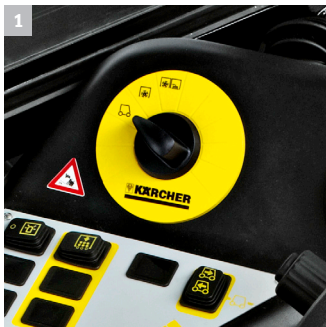

1 EASY Operation: multi-information display

The Kärcher EASY Operation concept has self-explanatory symbols for intuitive use and preventing incorrect operation. All displays are in the operator's field of vision and can be read at a glance. A comfortable and ergonomic operator workplace ensures greater safety and productivity.

2 Lasting power: choose LPG

The KM 130/300 and the KM 150/500 are operated with LPG power, for emission-free, quiet and long periods of uninterrupted use.

3 Flexible Footprint System

The Flexible Footprint System combines the advantages of rigid and floating roller brushes. The roller brush, which adapts to any unevenness in the surface, can be operated with variable contact pressure. For great cleaning results with minimum wear and tear.

4 Container lift

For quick and easy emptying of the waste container, both machines have a hydraulic container lift. The dirt can be emptied at various heights, whether onto the ground in a yard, or directly into a container.

KM 130/300 R

NEW



High capacity and power for heavy-duty use.

This powerful sweeper with fully hydraulic traction drive and sweeping system cleans all industrial surfaces effortlessly - from fine dust to construction waste. High working and transport speed and simple no-tools brush roller replacement shorten prep times and increase efficiency. The Lpg version KM 130/300 R ensures professional cleanliness even in noise-sensitive indoor areas.



Equipment presented with additional side broom and canopy, available on request. See optional items.

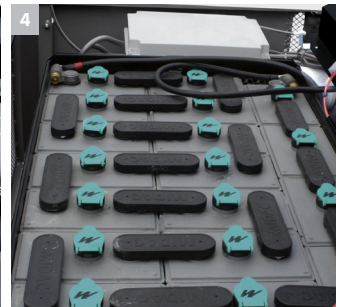
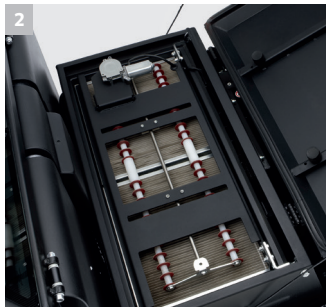

1 Rugged construction

- Solid steel frame.
- Fully hydraulic traction drive.

2 Efficient long-life filter

- Flat fold filter with 59 ft² filter area.
- Effective filter cleaning with dual scraper for dust free sweeping.

3 User-friendly design

- Easy-Operation design.
- Easy to get in and out.
- Extremely service-friendly.

4 Long run times

- Lpg for indoor and outdoor use.
- Emission-free and environmental friendly.
- Low-noise level.

KM 150/500 R



Maximum performance for the toughest jobs.

Built up for the toughest jobs with its robust steel chassis, durable and reliable components and an outstanding dust filter system, this machine fits well in heavy duty industrial environments. If a low noise level or emission-free work is required the LPG version is the only one in the market in this size range. The KM 150/500 enables high working and transport speeds, low-maintenance, fully hydraulic traction drive and sweeping system.

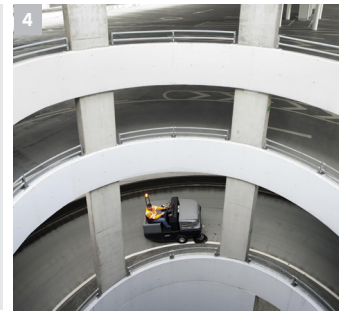
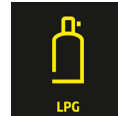

1 Efficient filter system

- Flat fold filter with 75 ft² filter area.
- Effective filter cleaning with dual scraper for dust free sweeping.

2 Comfortable workplace

- All controls are clearly arranged and easy to reach.
- All displays in operator's field of vision.

3 Easy to service

- Perfect access to service relevant parts.
- Main roller brush and filter can be replaced without tools.

4 Long run times

- LPG-drive.
- Emission-free and environmental friendly.
- Low-noise level.

Technical Data and Equipment.



KM 130/300 R Lpg

KM 150/500 R Lpg

- Easy roller brush replacement without tools
- Fully hydraulic drive and sweeping system
- High working and transport speed

Technical data

Drive		Four-stroke Lpg engine - Kubota	Four-stroke Lpg engine / Kubota
Power		17.5 kW	22 kW
Max. area performance - 2 SB	ft² / h	139,932 (13,000 m ² /h)	193,752 (18,000 m ² /h)
Working width - main broom	inches	39 (1000 mm)	47 (1200 mm)
Working width with 1/ 2 brushes	inches	51 (1300mm) / 61 (1550 mm)	59 (1500 mm) / 71 (1800 mm)
Waste container capacity	gallons	81 (300 l)	132 (500 l)
Climbing capacity	%	18	18
Working speed	mph	6 (10 km/h)	7 (12 km/h)
Filter area	ft²	59 (5,5 m ²)	75 (7 m ²)
Weight	lbs.	1,875 (850 kg)	3,119 (1,415 kg)
Dimensions (L x W x H)	inches	81" x 52" x 56" (2150 mm x 1330 mm x 1430 mm)	96" x 61" x 65" (2442 mm x 1550 mm x 1640 mm)

Equipment

Product	Order No.	Description
KM 130/300 R Lpg	9.841-398.0	KM 130/300 R Lpg
KM 150/500 R Lpg	9.841-404.0	KM 150/500 R Lpg

Accessories KM 130/300 R



Standard Accessories (included)

Order No.	Description	Image
6.987-438.0	Main Roller Brush, regular, 39" (1000 mm) - standard for Bp machine	
	Warning Beacon	
4.515-328.0	Front Wheel, solid rubber, puncture-proof, non-marking (set of 2)	1
6.988-158.0	Flat pleat filter, green, standard	
6.987-083.0	Side Brush, regular	

Optional Accessories

Order No.	Description	Image
6.987-439.0	Main Roller Brush, hard, 39" (1000 mm)	
6.987-460.0	Main Roller Brush, soft, 39" (1000 mm)	
6.987-440.0	Main Roller Brush, soft, natural 39" (1000 mm)	
8.638-972.0	Left Side Broom Kit. Factory install only.	
6.987-519.0	Flat pleat filter, white	2
4.515-332.0	Front Wheel, pneumatic (set of 2)	
8.636-955.0	Overhead Guard. Factory install only.	
8.636-956.0	Overhead Guard w/windscreen & wiper. Factory install only.	3
8.636-889.0	Dust control cover for side brush. Factory install only.	
6.905-773.0	Side Brush, hard	
6.905-620.0	Side Brush, soft	
6.905-619.0	Side Brush, hard steel bristles	
8.636-953.0	Front/Rear Light kit. Factory install only.	4
8.636-957.0	Closed Cab w/plastic curtains. Factory install only.	5
8.640-256.0	Comfort Seat	
8.640-208.0	Seat Belt	
8.638-973.0	Water spray dust control system. Factory install only.	

Accessories KM 150/500 R



Standard Accessories (included)

Order No.	Description	Image
	Warning Beacon	1
6.987-083.0	Side Brush, regular	
6.987-085.0	Main Roller Brush, regular, 47" (1200 mm) - standard for Bp machine	
4.515-329.0	Front Wheel, solid rubber, puncture-proof (set of 2)	
6.988-159.0	Flat pleat filter, green, standard	

Optional Accessories

Order No.	Description	Image
6.905-773.0	Side Brush, hard	
6.905-620.0	Side Brush, soft	
6.905-619.0	Side Brush, hard steel bristles	
8.636-953.0	Front/Rear Light kit. Factory install only.	2
8.640-256.0	Comfort Seat	
8.640-208.0	Seat Belt	
6.987-436.0	Main Roller Brush, hard, 47" (1200 mm)	
6.987-437.0	Main Roller Brush, soft, natural 47" (1200 mm)	
8.636-989.0	Left Side Broom kit. Factory install only.	3
6.987-177.0	Flat pleat filter, white	
8.638-992.0	Dust control cover for side brush. Factory install only.	4
8.638-990.0	Overhead Guard. Factory install only.	5
8.638-991.0	Overhead Guard w/windscreen & wiper. Factory install only.	
8.638-975.0	Water spray dust control system (factory install only)	

Please contact us for more information:

Kärcher Canada Inc.

6535 Millcreek Drive
Unit 67
Mississauga, ON L5N 2M2
Canada

Phone 888-705 9444
Fax 800-465-6013

www.karcher.ca