

FloorMaster[®]

FM 1000-E-24V

The FloorMaster[®] is intended for use as floor cleaning unit. In connection with a suction device the surface is cleaned and simultaneously disposed in a nonpolluting way. The high temperature resistant up to 95°C makes the FloorMaster[®] in connection with WOMA Ecotherm[®] units to an extremely efficient water tool.

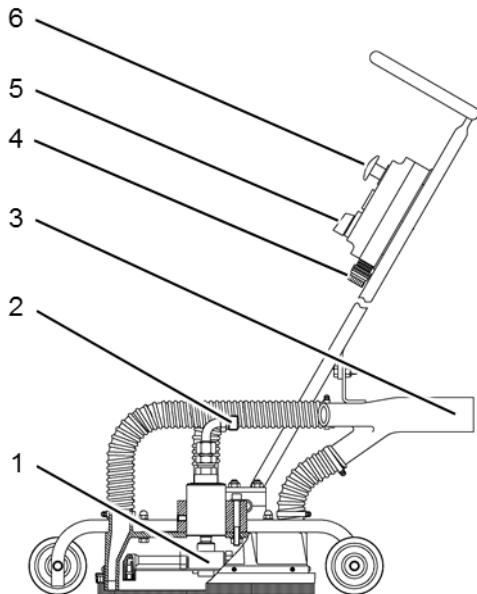

- 1 Nozzle bar
- 2 High pressure connection
- 3 Suction connection
- 4 Electric control cable connection
- 5 High pressure ON/OFF
- 6 EMERGENCY-STOP

Special benefits

- Using a suction device a separate disposal of suspension risen from cleaning is not necessary.
- Height adjustment for spray bar
- Speed control by nozzle adjustment

Technical data	
Material no.	6.025-260.0
Operating pressure	max. 1,000 bar
Volume flow	max. 25 l/min
Medium temperature	max. 100 °C
Weight	approx. 23 kg
Working width	approx. 300 mm
Height	approx. 1,100 mm
Length	approx. 800 mm
Control voltage	24V DC
Speed spray bar	1,500 1/min
Suction connection	DN 70
High pressure connection	M24x1.5 (24°DK)
No. of nozzles	2
Recommended nozzles	Form 4 or Form 19

Nozzle selection* – Ecotherm [®] 600	
Ø 0.9 mm, Form 4	2 x 6.025-470.0
Ø 1.1 mm, Form 19 (30°)	2 x 6.025-467.0

* Other combinations on request

Nozzle selection* – Ecotherm [®] 800	
Ø 0.7 mm, Form 4	2 x 9.885-950.0
Ø 0.8 mm, Form 19 (30°)	2 x 9.886-186.0

* Other combinations on request

Accessories	
Sealing for nozzle	2 x 6.025-168.0
Adjustment tool for nozzle Form 19	9.883-958.0
Nut runner for nozzle Form 4 and Form 19	9.883-469.0
Vacutec	9.740-045.0