

FlexLanceMaster[®]

Hose feeding device

FlexLanceMaster[®] is a pneumatic hose feeding device for the remote-controlled extension and retraction of high-pressure cleaning hoses in tube bundle heat exchangers. This makes it a sensible extension to the portal system PreventMaster[®] (not included). With the wide selection of the roller sets, the system can be adapted to many applications.

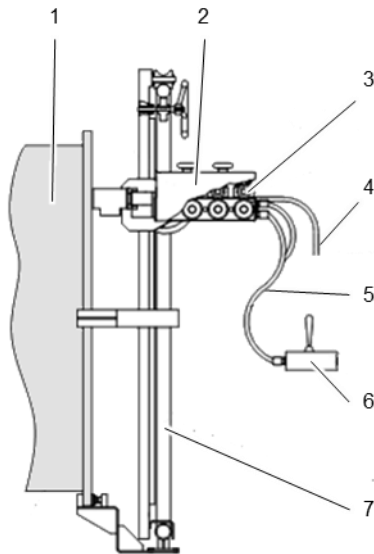

- 1 Tube bundle heat exchanger
- 2 Safety cover
- 3 Hose feeding device
- 4 High pressure hose
- 5 Control hose
- 6 Control unit
- 7 PreventMaster[®]
(not included)

Special benefits

- Maximum working safety
- Effortless work
- Pneumatically controlled feed movement
- Easy assembly and setup

Technical data	
Material-Number	9.871-146.0*
Weight	approx. 12 kg
Required air pressure (oiled)	3 - 7 bar
Air consumption at 6.3 bar	0.468 m ³ /min
Air connection	DN9-NW7.2
Feeding speed at 6.3 bar	max. 8 m/min
Length of control hose	5 m

* FlexLanceMaster[®] is delivered without roller sets, this is to be ordered specifically from the accessory program.

Accessories

Roller sets	
Hose outer diameter [mm]	Material- Number
Ø 7.7 – Ø 8.0	9.872-173.0
Ø 9.5 – Ø 9.8	9.872-172.0
Ø 10.7 – Ø 11.0	9.872-171.0
Ø 11.5 – Ø 11.8	9.872-170.0
Ø 12.6 – Ø 12.9	9.907-683.0
Ø 13.0 – Ø 13.3	9.907-682.0
Ø 15.0 – Ø 15.3	9.872-167.0
Ø 16.9 – Ø 17.2	9.872-166.0