

High-pressure pump 1000M

The type 1000M high-pressure pump provides a max. operating pressure of 3,000 bar and a max. flow rate of 218 l/min.



The high-pressure plunger pumps of the M-series provide working pressures of up to 3,000 bar. This makes the pumps of the M-series ideal for work such as cutting, fragmenting, stripping and de-rusting.

Built in central valve design, these plunger pumps have high volumetric efficiencies even at high pressures. The hard metal plungers used are extremely stable and ensure a long service life and therefore low maintenance costs. Furthermore, they are insensitive to temperature shocks. The guide of the plunger as well as the sealing water system ensures a long service life of the sealing system and counteracts the intrusion of air.

On request, the availability of an ATEX version can be checked.

Technical data		
Weight	approx.	2.470 kg
Inlet pressure connection		IG 2"
Pressure connection with flange		9/16" UNF-LH
Cooling water connection		IG 1/2"
Crankshaft	max. min.	500 1/min Depends on operation parameters
Drive shaft		Diameter 75mm k6, Clutch mounting with clamping set
Torque at drive shaft	max.	4,600 Nm
Moment of inertia J	i = 3.00 i = 3.69 i = 4.23	1.197 kgm ² 0.924 kgm ² 0.777 kgm ²
Centrifugal moment GD ²	i = 3.00 i = 3.69 i = 4.23	46.97 Nm ² 36.26 Nm ² 30.48 Nm ²
Inlet pressure	min. max.	1.5 bar 5.0 bar
Pressure amplitude	max.	± 2.0 bar
Flow temperature	min. max.	+5 °C +30 °C (higher temperatures on request)
Flow inlet requirement	min.	1.5x nominal feed rate of the pump, dependent on the conversion set
Emission sound pressure level according to DIN EN ISO 11200		>80 dB(A)
Oil capacity of transmission end	approx.	45 l
Oil viscosity ISO VG under DIN 51517-2 or -3		320 mm ² /s
Oil pressure lubrication		2.5 - 5.0 bar
Oil pressure set value overflow valve		5.0 bar
Oil filter fineness		0.025 mm
Oil temperature	max. Set value	80 °C 60 - 70 °C
Heat exchanger cooling water requirement	appr.	20 - 30 l/min
Heat exchanger cooling water temperature	min. max.	+5 °C +45 °C
Heat exchanger cooling water pressure	min. max.	1.5 bar 10 bar

Performance variants**										
Pinion shaft		Crank shaft	P22		P24		P26		P28	
1,500 [1/min]	1,800 [1/min]		3,000 bar*		2,500 bar		2,000 bar		1,800 bar	
Gear ratio		[1/min]	[kW]	[l/min]	[kW]	[l/min]	[kW]	[l/min]	[kW]	[l/min]
3.00		500*	685	126	700	154	676	186	713*	218*
	3.69	488	668	122	683	150	659	181	696	213
	4.23	426	583	107	596	131	575	158	607	186
3.69		407	558	102	569	125	549	151	580	177
4.23		355	486	89	496	109	479	132	506	155

* Maximum values of the pump

** Technical changes reserved

Overview pump 1000M

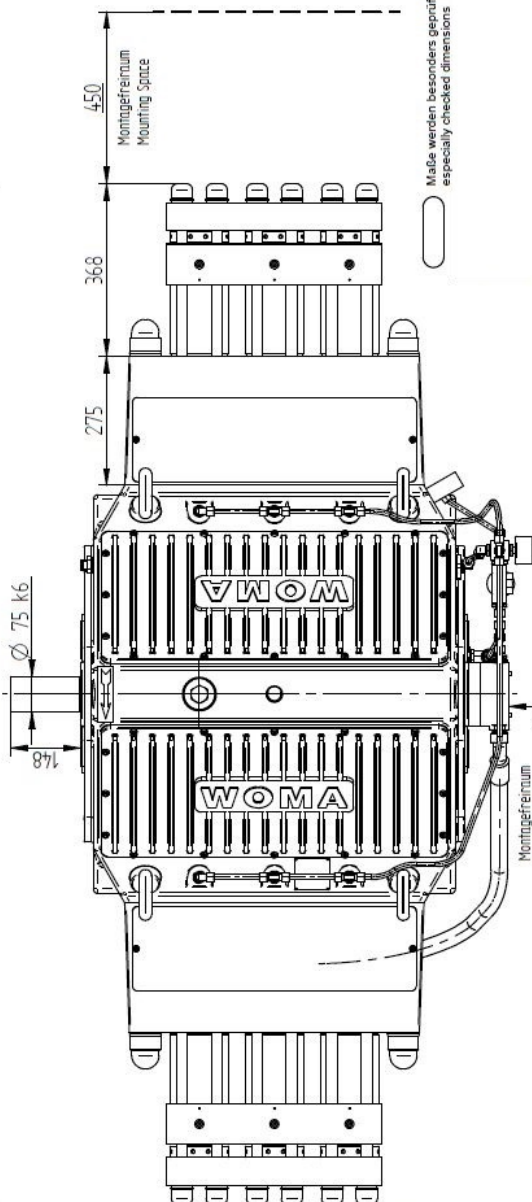
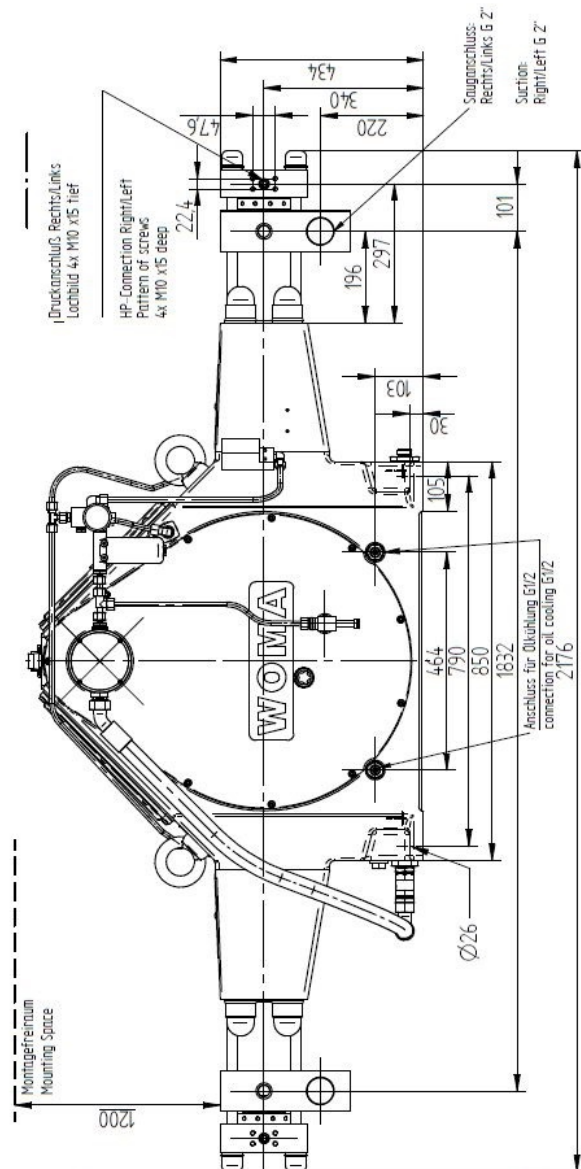
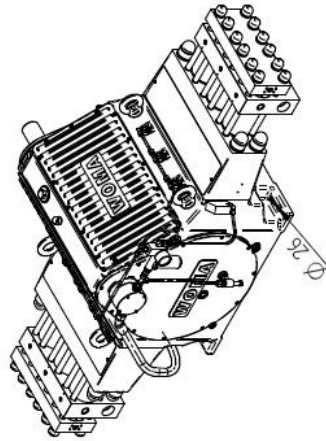
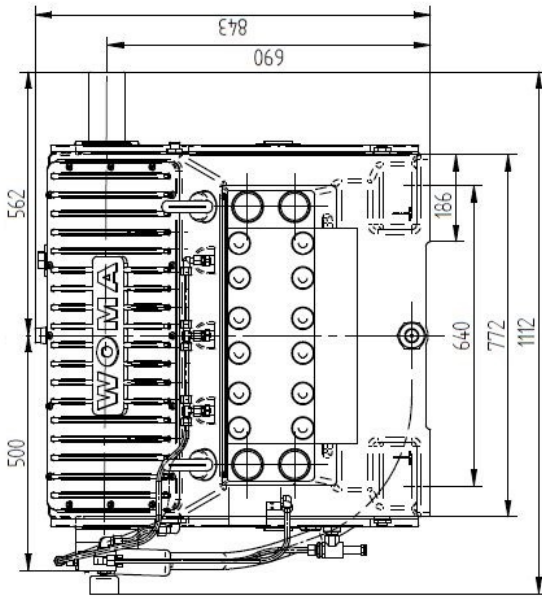

Ölfüllung: ca. 45l
Gewicht: ca. 24,70kg netto
Alle Maße in mm
Gewinde "M" nach DIN 13 / ISO 261
Gewinde "G" nach DIN ISO 228 / 1

Öl capacity: approx. 45l
Weight: approx. 24,70kg net
All dimensions in mm
Thread "M" as per DIN 13 / ISO 261
Thread "G" as per DIN ISO 228 / 1