

High Pressure Gun

HP 1500S-VDG-Ergo

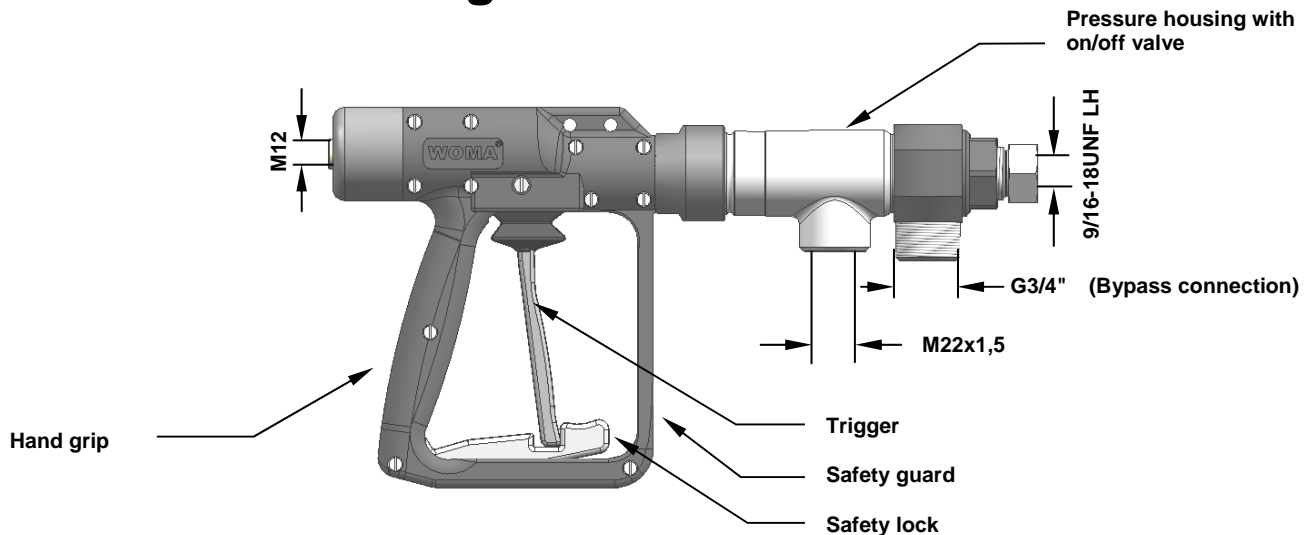

Description:

The HP 1500S-VDG-Ergo is a positive shutoff type high pressure jetting gun which incorporates an internal on/off valve and a bypass for a max. operating pressure of 1500 bar.

A patented power transfer mechanism prevents premature fatigue of the operator's hand and has a positive effect on the service life of the gun.

In non actuating trigger position, the flow medium will be lead through the bypass line and the high pressure aggregate becomes pressureless.

Standard equipment includes; a trigger safety guard and latching trigger lock to prevent unintentional use, forged steel pressure housing and light weight polymerized hand grip.

Advantages:

- High safety standard.
- Patented power transfer mechanism.
- Quick switching operation.
- Turnable hand grip for easy operation.
- Full encapsulated polymerized hand grip offers high tensile strength and excellent resistant to most chemicals.
- All functional parts are protected from dirt and water invasion.

Technical data:

Material-No.:	9.915-412.0
Operating pressure:	max. 1500 bar
Medium temperature:	max. 100 °C
Recoil force perm. without body support:	max. 150 N
Recoil force perm. with body support:	max. 250 N
Weight:	appr. 3 kg
Length:	appr. 360 mm
Height:	appr. 200 mm
Width:	appr. 50 mm

HP 1500S-VDG-Ergo – Components

Nozzle connection	
Material No.	Nozzle form
9.873-090.0	1 and 8
9.872-008.0	4 and 19
9.878-291.0	21

Nozzle connection for nozzle form
4 for coherent jet forming
Mat.-No.: 9.872-183.0

Orbimaster

Turbo nozzle

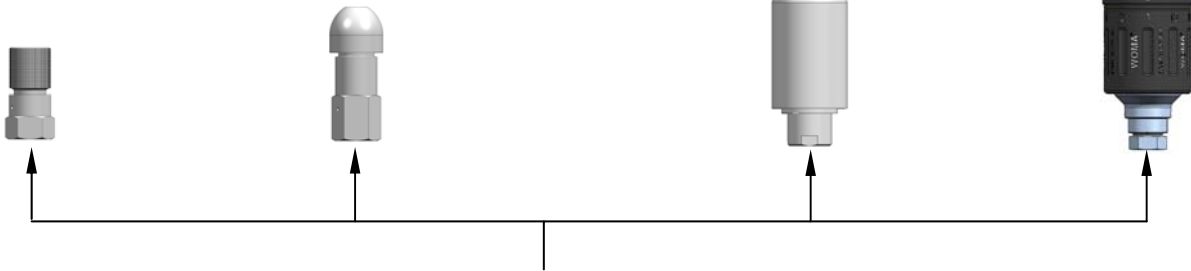

Nozzle pipe		Weight
Material No.	L (mm)	kg
9.891-181.0	300	0,26
9.891-182.0	500	0,43
9.891-183.0	750	0,64
9.891-184.0	1000	0,85
9.891-207.0	1500	1,30
9.891-185.0	2000	1,69
9.891-186.0	3000	2,53
9.891-187.0	4000	3,37
9.891-188.0	5000	4,21
9.891-189.0	6000	5,05
9.891-383.0	7000	5,89

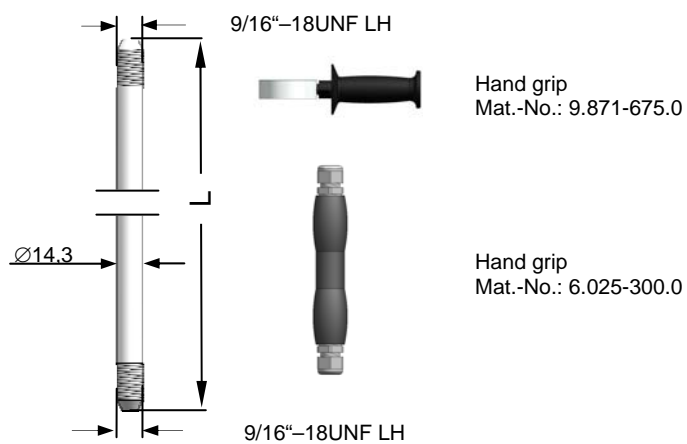

Bypass Hose
Mat.-No.: 9.887-970.0
Weight: ca. 0,6 kg
Length: 1,5 m

Gun housing HP 1500S-VDG-Ergo
Mat.-No.: 9.915-412.0
Weight: appr. 3,0 kg

Body support
Mat.-No.: 6.025-301.0
Weight: appr. 0,73 kg

Turnable hose connection	
Material No.	B
9.872-624.0	M22x1,5 24° DK
9.872-436.0	M22x1,5 60° DK
9.872-437.0	M24x1,5 24° DK
9.872-438.0	G1/2 60° DK

Hose connection	
Material No.	A
9.871-967.0	M22x1,5 24° DK
9.871-968.0	M22x1,5 60° DK
9.871-969.0	M24x1,5 24° DK
9.871-970.0	G1/2 A 60° DK
9.871-971.0	G3/4 A 60° DK

