

KÄRCHER

makes a difference

High pressure cleaner
Electric motor - Cold water

English..... 3

MODELS:

1.106-160.0
HD 2.0/1000 Dual Mister

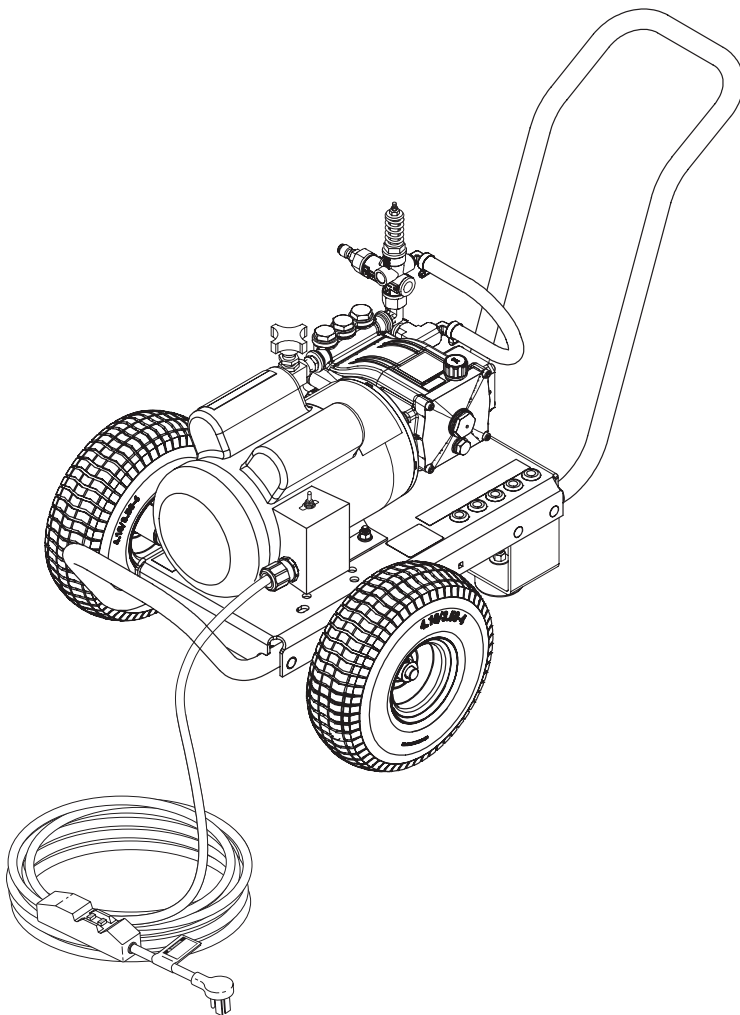

**Register
your product**

www.kaercher.com/welcome



9.808-246.0-C (09/10/20)

CONTENTS

Important Safety Information	4-5
Operating instructions for misting mode	6
Operating instructions for high pressure mode.....	7
Exploded View	8
Exploded View Parts List	9-10
Pump Assembly, Exploded view	11
Filter Exploded view.....	12
Cleaning The Water Inlet Filter	13
LF2030S Series Pump Exploded view and part's list	14-15
VRT3 Unloader exploded view and part's list	16
Wiring Diagram	17
Troubleshooting	18
Preventative Maintenance	19

INTRODUCTION & IMPORTANT SAFETY INFORMATION

Thank you for purchasing this Pressure Washer.

We reserve the right to make changes at any time without incurring any obligation.

Owner/User Responsibility:

The owner and/or user must have an understanding of the manufacturer's operating instructions and warnings before using this pressure washer. Warning information should be emphasized and understood. If the operator is not fluent in English, the manufacturer's instructions and warnings shall be read to and discussed with the operator in the operator's native language by the purchaser/owner, making sure that the operator comprehends its contents.

Owner and/or user must study and maintain for future reference the manufacturers' instructions.

The operator must know how to stop the machine quickly and understand the operation of all controls. Never permit anyone to operate the engine without proper instructions.

SAVE THESE INSTRUCTIONS

This manual should be considered a permanent part of the machine and should remain with it if machine is resold.

When ordering parts, please specify model and serial number. Use only identical replacement parts.

This machine is to be used only by trained operators.

single phase this product should only be connected to a power supply receptacle protected by a GFCI.

DANGER: Improper connection of the equipment-grounding conductor can result in a risk of electrocution. Check with a qualified electrician or service personnel if you are in doubt as to whether the outlet is properly grounded. Do not modify the plug provided with the product - if it will not fit the outlet, have a proper outlet installed by a qualified electrician. Do not use any type of adaptor with this product

DANGER: Une mauvaise connexion du conducteur de terre de l'équipement peut entraîner un risque d'électrocution. Vérifier auprès d'un électricien qualifié ou du personnel d'entretien si vous avez des doutes quant à savoir si la sortie est correctement mise à la masse. Ne pas modifier la fiche fournie avec le produit - si elle n'entre pas dans la sortie, faire installer une sortie appropriée par un électricien qualifié. Ne jamais utiliser un adaptateur avec ce produit.

IMPORTANT SAFETY INFORMATION

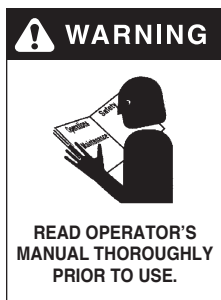

WARNING: To reduce the risk of injury, read operating instructions carefully before using.

AVERTISSEMENT: Pour réduire le risque de blessures, lire attentivement les instructions de fonctionnement avant l'utilisation.

1. Read the owner's manual thoroughly. Failure to follow instructions could cause malfunction of the machine and result in death, serious bodily injury and/or property damage.

2. Know how to stop the machine and bleed pressure quickly. Be thoroughly familiar with the controls.
3. Stay alert — watch what you are doing.
4. All installations must comply with local codes. Contact your electrician, plumber, utility company or the selling distributor for specific details. If your machine is rated 250 volts or less, single phase will be provided with a ground fault circuit interrupter (GFCI). If rated more than 250 volts, or more than



WARNING: Keep wand, hose, and water spray away from electric wiring or fatal electric shock may result.

DANGER: Garder la lance, le boyau et le jet d'eau à l'écart de tout câblage électrique ou des chocs électriques mortels pourraient survenir.

5. To protect the operator from electrical shock, the machine must be electrically grounded. It is the responsibility of the owner to connect this machine to a UL grounded receptacle of proper voltage and amperage ratings. Do not spray water on or near electrical components. Do not touch machine with wet hands or while standing in water. Always disconnect power before servicing.



WARNING: Flammable liquids can create fumes which can ignite, causing property damage or severe injury.

AVERTISSEMENT: Des liquides inflammables peuvent produire des vapeurs qui peuvent s'enflammer, causant ainsi des dommages à la propriété ou des blessures graves.

WARNING: Risk of explosion — Do not spray flammable liquids.

AVERTISSEMENT: Risque d'incendie - Ne pas pulvériser de liquides inflammables.

6. Do not allow acids, caustic or abrasive fluids to pass through the pump.

IMPORTANT SAFETY INFORMATION

7. Never run pump dry or leave spray gun closed longer than 1-2 minutes.
8. Keep operating area clear of all persons.



WARNING: High pressure spray can cause paint chips or other particles to become airborne and fly at high speeds. To avoid personal injury, eye, hand and foot safety devices must be worn.

AVERTISSEMENT: Un jet haute-pression peut écailler la peinture ou provoquer l'émission d'autres particules dans l'air et leur projection à hautes vitesses. Pour éviter les lésions corporelles, une protection des yeux, du visage, des mains et des pieds doit être portée lors de l'utilisation de cet équipement.

9. Eye, hand, and foot protection must be worn when using this equipment.

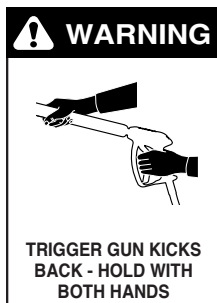

WARNING: Grip cleaning wand securely with both hands before starting. Failure to do this could result in injury from a whipping wand.

AVERTISSEMENT: Agripper la lance de nettoyage avec les deux mains avant de commencer. Le non-respect de cette consigne pourrait mener à des blessures

causées par le mouvement violent de la lance.



WARNING: High pressure developed by these machines will cause personal injury or equipment damage. Keep clear of nozzle. Use caution when operating. Do not direct discharge stream at people, or severe injury or death will result.

AVERTISSEMENT: La haute pression générée par ces machines causera des lésions corporelles ou des dommages à l'équipement. Se tenir à l'écart de la buse. Faire preuve de prudence lors de l'utilisation. Ne pas décharger directement le jet vers des personnes ou des animaux, car cela risquerait de causer des blessures graves ou même la mort.

10. To reduce the risk of injury, close supervision is necessary when a machine is used near children. Do not allow children to operate the pressure washer. **This machine must be attended during operation.**
11. Never make adjustments on machine while in operation.

12. Be certain all quick coupler fittings are secured before using pressure washer.



WARNING: Protect machine from freezing.

AVERTISSEMENT: Protéger la machine contre le gel.

13. To keep machine in best operating conditions, it is important you protect machine from freezing. Failure to protect machine from freezing could cause malfunction of the machine and result in death, serious bodily injury, and/or property damage. Follow storage instructions specified in this manual.

14. Inlet water must be clean fresh water and no hotter than 90°F.
15. Manufacturer will not be liable for any changes made to our standard machines or any components not purchased from us.
16. The best insurance against an accident is precaution and knowledge of the machine.



WARNING: Be extremely careful when using a ladder, scaffolding or any other relatively unstable location. The cleaning area should have adequate slopes and drainage to reduce the possibility of a fall due to slippery surfaces.

AVERTISSEMENT: Une modification non autorisée de la machine ou l'utilisation de pièces de rechange non approuvées peut causer des lésions corporelles et/ou des dommages à la propriété, et annulera la garantie du fabricant.

17. Do not overreach or stand on unstable support. Keep good footing and balance at all times.
18. Do not operate this machine when fatigued or under the influence of alcohol, prescription medications, or drugs.

WARNING: Do not spray machine or any people, animals or electrical parts.



AVERTISSEMENT: Ne pas vaporiser sur la machine ou les gens, les animaux ou les pièces électriques.



Follow the maintenance instructions specified in the manual.

OPERATING INSTRUCTIONS FOR MISTING MODE

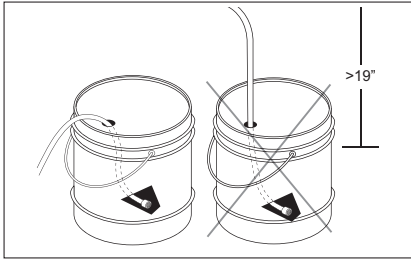

STEP 1: Attach ½” hose to a disinfectant bucket (Recommendable that water inlet is at floor level). We recommend Vital Oxide

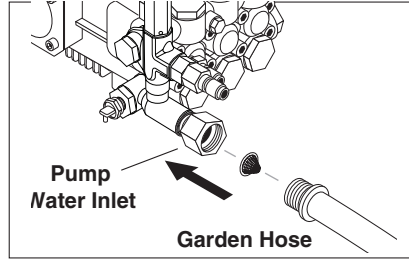

STEP 2: Connect ½” hose to pump Water inlet. Inspect inlets.
CAUTION: Do not run the pump without water or pump damage will result.

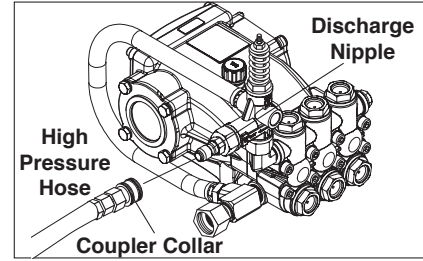

STEP 3: Connect ¼” high pressure hose to the discharge nipple. Push coupler collar forward until secure.

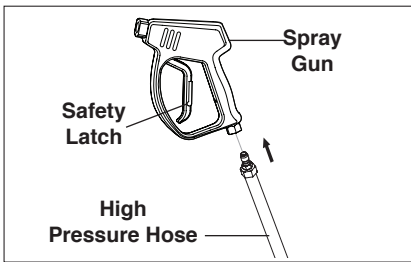

STEP 4: Attach the high pressure hose to the spray gun.

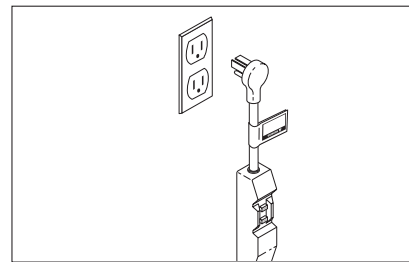

STEP 5: Connect to appropriate power supply. Push reset button on GFCI.

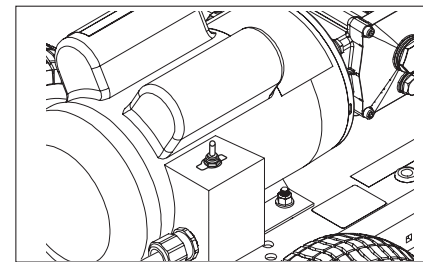

STEP 6: Start up the machine.

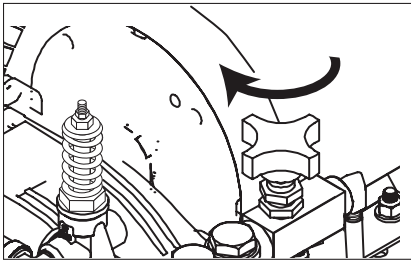

STEP 7: Close metering valve to purge hose.

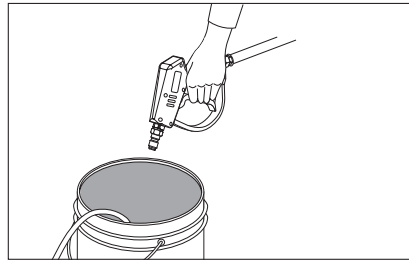

STEP 8: Purge any air trapped in hose (Recommend to do this over the disinfectant bucket).

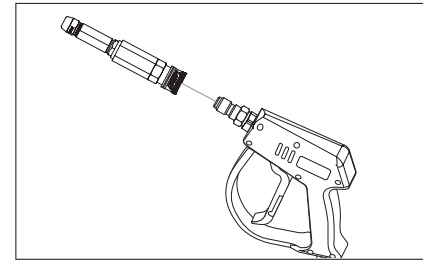

STEP 9: Attach misting nozzle into the spray gun.

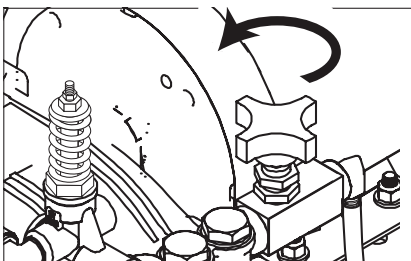

STEP 10: Open metering valve to use Misting mode.

CAUTION: If valve stays close in misting mode nozzle may get damage

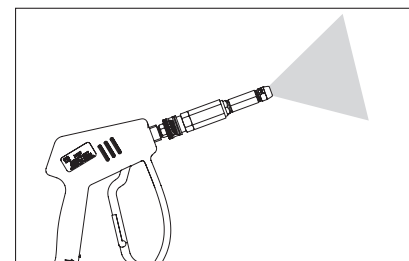

STEP 11: Ready to use, mist Vital Oxide disinfectant.

OPERATING INSTRUCTIONS FOR HIGH PRESSURE MODE

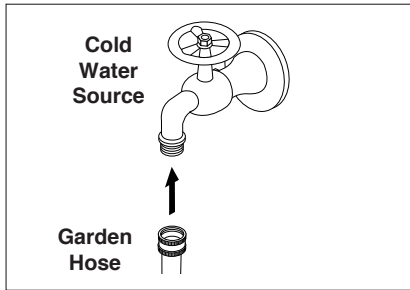

STEP 1: Connect 1/2" hose to cold water inlet.

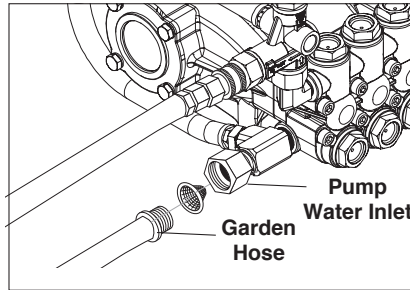

STEP 2: Check inlets filters, remove debris, then connect the garden hose to pump water inlet.

CAUTION: Do not run the pump without water or pump damage will result.

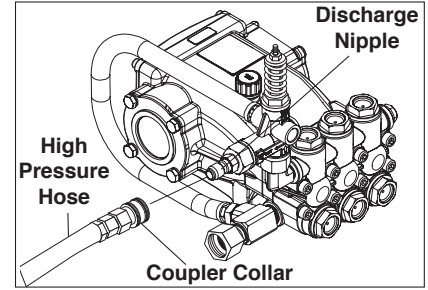

STEP 3: Connect 1/4" high pressure hose to the discharge nipple. Push coupler collar forward until secure.

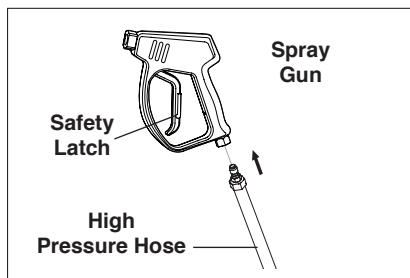

STEP 4: Attach the high pressure hose to the spray gun.

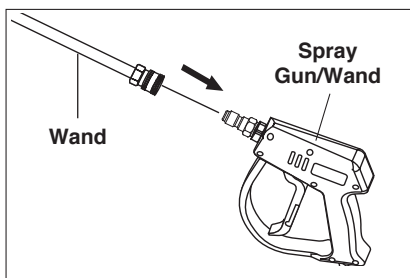

STEP 5: Attach wand to spray gun.

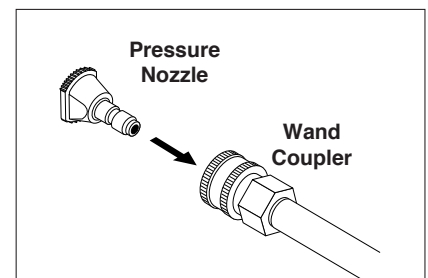

STEP 6: Pull spring-loaded collar of the wand coupler back to insert your choice of pressure nozzle.

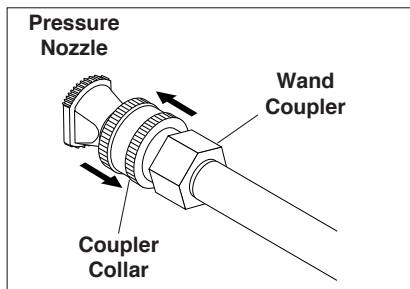

STEP 7: Close metering valve to purge hose.

CAUTION: If valve is open, pressure wont reach rate

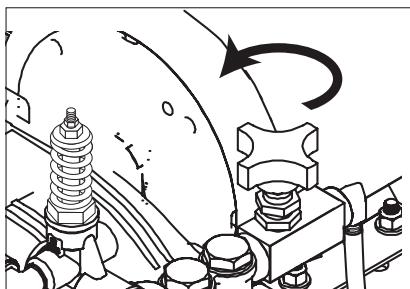

STEP 8: Open metering valve to use Misting mode.

CAUTION: If valve stays close in misting mode nozzle may get damage

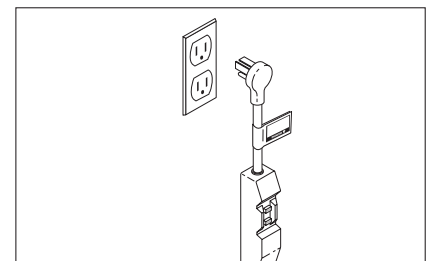

STEP 9: Connect to appropriate power supply. Push reset button on GFCI.

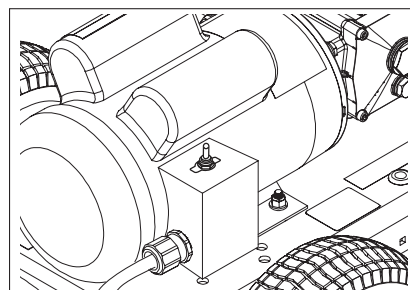

STEP 10: Start up the machine.

EXPLODED VIEW

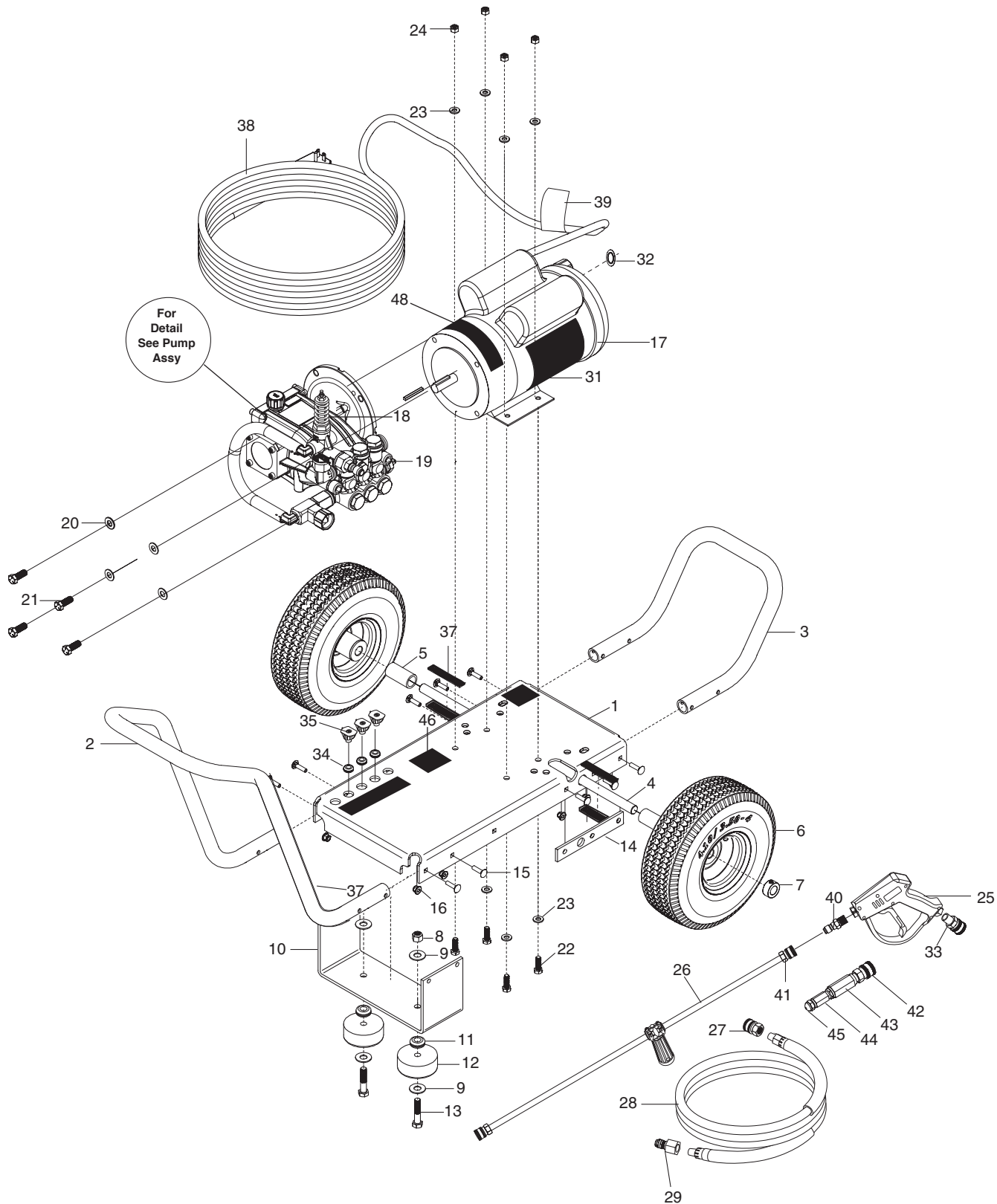

EXPLODED VIEW PARTS LIST

ITEM	PART NO.	DESCRIPTION	QTY
1	8.924-115.0	Al Base Direct Drive	1
2	8.924-394.0	Al Handle	1
3	8.924-393.0	Al Bumper	1
4	9.803-097.0	Axle, 5/8 X 20.125 Long	1
5	8.924-179.0	AL Spacer Tube DD Frame	2
6	8.756-365.0	QH Wheel Assy 10", Gray STL RIM, Flat	1
7	9.802-782.0	Collar, 5/8" Bore Shaft 3010	2
8	9.197-003.0	3/8-16 NE Nylon Insert L/N ZC 5UM White	2
9	9.802-817.0	Washer, 3/8" x 1"	4
10	8.924-116.0	Foot AL DD Frame CW	1
11	9.802-064.0	Grommet, Rubber, Nozzle Holder	2
12	9.802-066.0	Pad Soft Rubber	2
13	9.196-041.0	Hex Head Bolt 3/8-16 X 1-3/4	2
14	8.924-074.0	Camaro Silver Axle Holder DD CW	1
15	9.802-706.0	Bolt, 1/4"-20 x 1-3/4" Carriage Zinc	8
16	9.197-010.0	1/4-20" Nylon Insert Lock Nut With Flange	10
17	9.804-516.0	Motor, 1.5HP 1PH, 115V 1725RPM, TEFC	1
18	8.750-299.0	Unloader, VRT3, 8 GPM @4500 PSI	1
19	8.754-761.0	Pump, Leuco LF2030S, 2.1@3000, 1725RPM	1
20	9.198-004.0	3/8", USS F/W Zinc	4
21	9.802-720.0	Bolt, 3/8" x 1", NC HH	4
22	9.802-710.0	Screw 5/16" x 1" NC	4
23	8.718-980.0	Washer, 5/16" Flat, SAE	8
24	9.802-776.0	Nut, 5/16-18, ESNA	4
25	8.750-247.0	Trigger Gun Model m407	1
26	8.783-039.0	Wand 30" Zinc Plated, Handle & Coupler	1
27	9.802-166.0	Coupler, 3/8" Socket, Female, Brass	2
28	8.925-393.0	Hose 1/4"x75' 4000 PSI SWxSW CPL S120	1
29	9.802-170.0	Coupler, 3/8" Plug, Female, Steel Zinc	1
30	8.900-305.0	Label, Landa, Home Depot, ZE Warning	1
31	9.800-037.0	Label, French Inst./Warn	1
32	9.803-834.0	Washer, Reducing 3/4" x 1/2"	1
33	9.802-169.0	Coupler, 3/8"Socket, Male, Brass	1
34	8.755-187.0	Grommet, Rubber, Nozzle Holder Base 3/16	5
35	8.712-338.0	Nozzle, SAQCMEG 1503.5, Yellow	1
	8.712-339.0	Nozzle, SAQCMEG, 2503.5, Green	1
	8.712-340.0	Nozzle, SAQCMEG 4003.5, White	1
36	9.800-016.0	Label, Disconnect Power Supply	1
37	8.755-210.0	Four Nozzle Label, Black	1
38	9.802-432.0	GFCI, 120V 15A, W/ 36' 12-3 CORD	1
39	8.932-969.0	Label, Warning, Service Cord	1
40	8.707-139.0	Coupler, 1/4"Plug, Male, Steel/Zinc	1
41	9.802-164.0	Coupler, 1/4"Socket, Female, Brass	1
42	8.756-030.0	Coupler, 1/4 Socket, Male, Brass	1
43	8.709-175.0	Filter,High Pressure 1/4"Npt-Fx1/4"Np	1
44	8.758-918.0	Adapter 9/16 X 1/4	1
45	8.756-697.0	Fuel Nozzle, 2.50 X 80 BZ	1
46	9.800-049.0	Label, Manufacturer's cleaning solution	1

PUMP ASSEMBLY EXPLODED VIEW

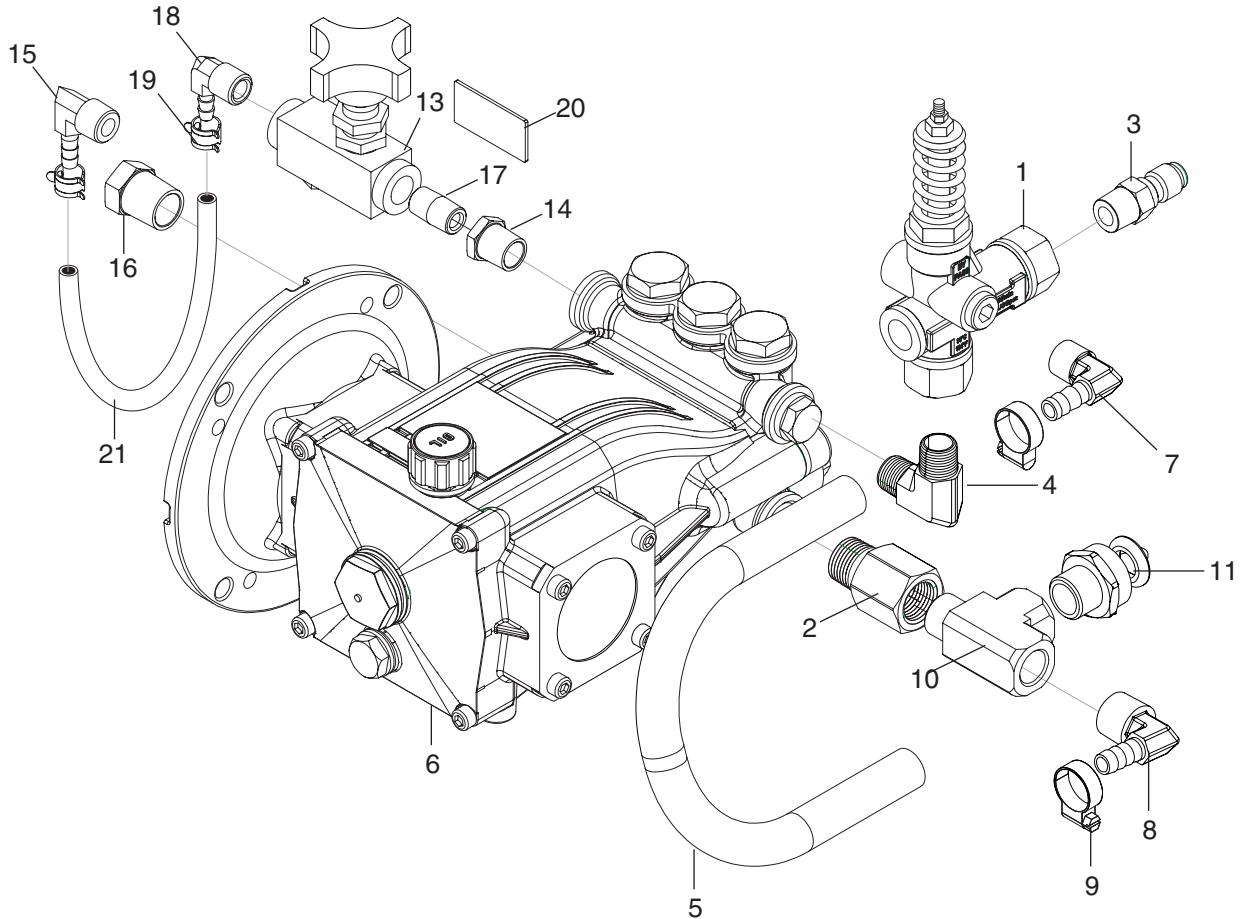

PUMP ASSY EXPLODED VIEW PARTS LIST

ITEM	PART NO.	DESCRIPTION	QTY	ITEM	PART NO.	DESCRIPTION	QTY
1	8.750-299.0	Unloader, Vrt3, 8 Gpm @4500 Psi	1	13	8.707-317.0	Valve, Flow Control	1
2	8.757-193.0	Adapter, 1/2" F-Nptf X 1/2" M-Nptf, Brass	1	14	8.706-297.0	Bushing, 3/8" X 1/4" Steel Yellow Chrom	1
3	8.707-152.0	Nipple, 3/8", Male, Ssteel	1	15	8.706-965.0	Hose Barb, 1/4" Barb X 3/8" Npt-M, 90	1
4	8.757-511.0	Elbow, 3/8", Steel	1	16	8.706-294.0	Bushing, 1/2" X 3/8", Steel P/N-5406-	1
5	8.711-785.0	Hose, 3/8 Push On	1	17	8.757-337.0	Nipple, 1/4" Close Sch 80 Steel, W/Slnt	1
6	8.758-069.0	Pump LEUCO LFP2030S, 2.1 @3000, 1725RPM	1	18	8.757-205.0	Hose Barb, 1/4" Barb X 1/4" M-Nptf, 90	1
7	8.705-119.0	Hose Barb, Elbow, 3/8"Barbx3/8"Mpt/90Deg	1	19	6.390-126.0	Clamp Hose	2
8	8.758-199.0	Hose Barb Elbow 3/8"X1/2" 90 Deg W/Slnt	1	20	8.758-919.0	Label Valve Label.	1
9	8.623-315.0	Clamp, 3/8 Hose (D-Slot)	2	21	9.802-254.0	Hose, 1/4 Push-On	5"
10	8.757-257.0	Tee, Street 1/2"	1				
11	8.757-203.0	Swivel, 1/2" M-Nptf X 3/4" Ghf	1				
12	9.804-016.0	Filter Screen Washer, Garden Hose/30Mesh	1				

FILTER EXPLODED VIEW

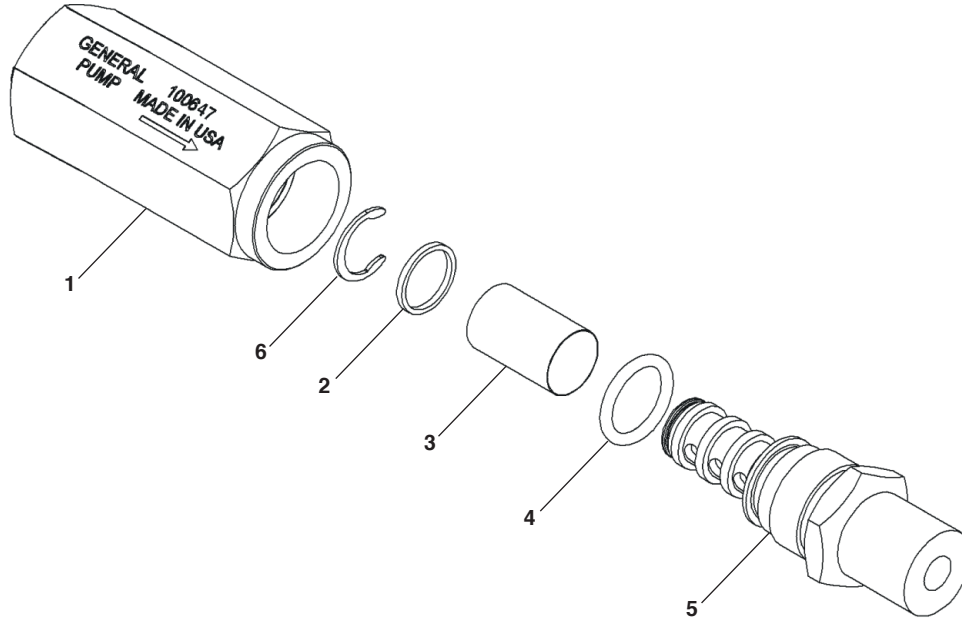

FILTER PARTS LIST

ITEM	DESCRIPTION	QTY
1	Housing, Nozzle Filter, 1/4 NPT-F	1
2	Retainer, Filter	1
3	Screen, 100 Mesh, T304SS	1
4	O-Ring, 70 Duro, Buna-N, .426 ID x .070 CS	1
5	Outlet Fitting, Nozzle Filter, 1/4 NTP-M	1
6	Retainer, External, SS	1

CLEANING THE WATER INLET FILTER

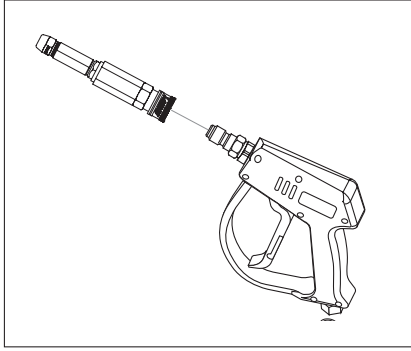

STEP 1: Disconnect Spray nozzle
From the machine

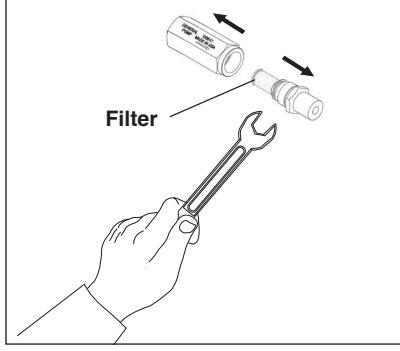

STEP 3: Pull out water inlet filter.
Use the necessary tools.

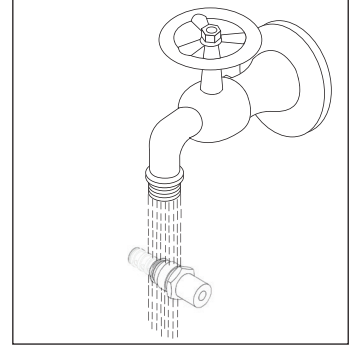

STEP 4: Rinse out water
inlet filter in warm water.

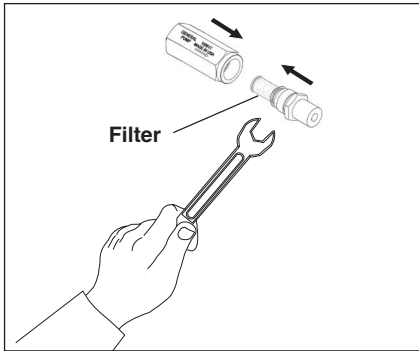

STEP 5: Assemble the water inlet
filter. Use the necessary tools.

LF 2030S SERIES PUMP EXPLODED VIEW

8.924-736.0 LF 2030S

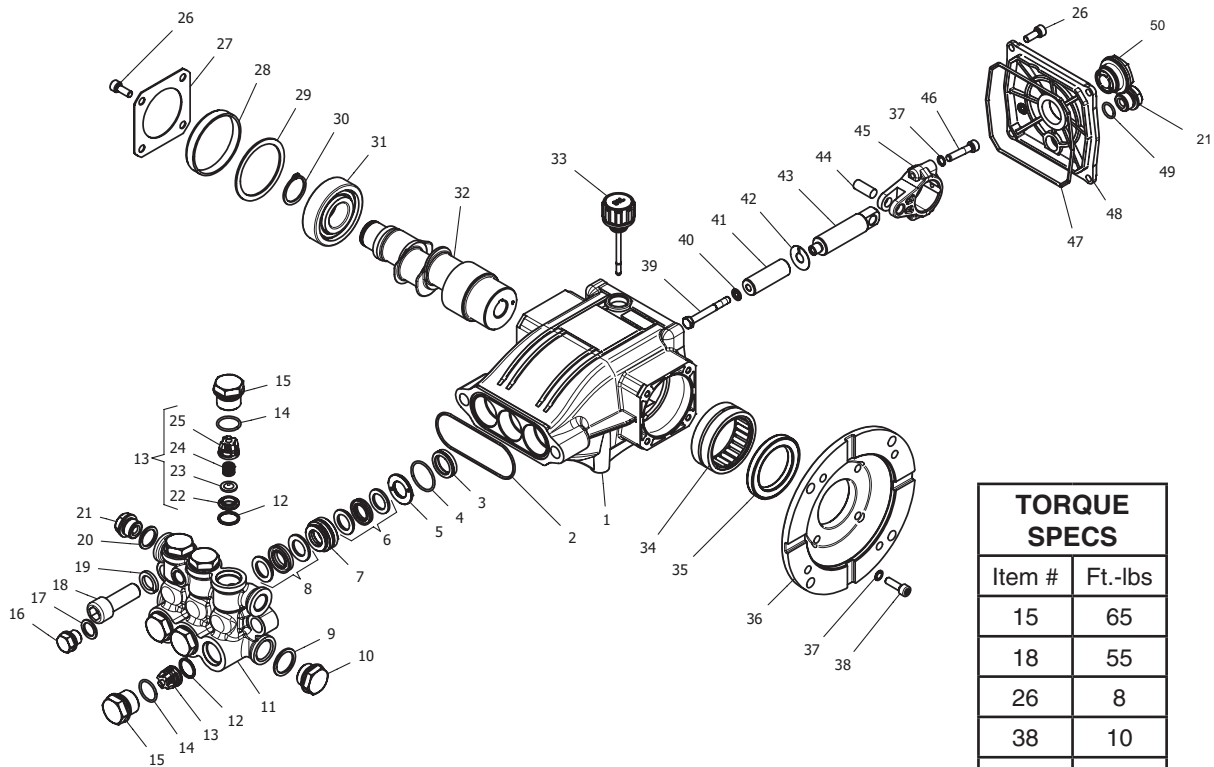

TORQUE SPECS	
Item #	Ft.-lbs
15	65
18	55
26	8
38	10
39	10
46	10

HF 2030S SERIES PUMP PARTS LIST

ITEM	PART NO.	DESCRIPTION	QTY	ITEM	PART NO.	DESCRIPTION	QTY
1	8.754-841.0	Crankcase	1	19	8.754-850.0	Washer, Lock	2
2	8.754-846.0	O-ring Ø1.78 X 72.75	1	20	9.803-198.0	Washer, Copper G3/8	1
3*	See Kits Below Plunger Oil Seal		3	21	8.707-262.0	Plug, Brass G3/8	2
4*	See Kits Below O-ring Ø1.78 X 26.7		3	22*	See Kits Below Valve Seat		6
5*	See Kits Below Washer, Pressure Ring		3	23*	See Kits Below Valve Plate		6
6*	See Kits Below U-Seal		3	24*	See Kits Below Valve Spring		6
7*	See Kits Below Pressure Ring		3	25*	See Kits Below Valve Cage		6
8*	See Kits Below U-Seal		3	26	9.802-939.0	Screw, M6 X 16	8
9	9.803-199.0	Washer, Copper G1/2	1	27	8.717-137.0	Bearing Cover	1
10	9.802-926.0	Plug, Brass G1/2	1	28	9.803-954.0	Bearing Seal	1
11	8.754-852.0	Manifold (16mm Models)	1	29	8.754-843.0	Seal Spacer, Crankshaft	1
	8.754-853.0	Manifold (14mm Models)	1	30	9.802-914.0	Snap Ring, 25 mm	1
12*	8.717-233.0	O-ring Ø1.78 X 15.6	6	31	9.803-955.0	Bearing, Ball	1
13*	See Kits Below Valve Assembly		6	32	8.754-836.0	Shaft, 5/8" Hollow	1
14*	9.803-948.0	O-ring Ø1.78 X 18.77	6	33	8.754-219.0	Oil Dipstick	1
15	9.803-949.0	Valve Plug	6	34	8.754-840.0	Bearing Needle	1
16	8.754-851.0	Plug, Brass G1/4 (16mm)	1	35	8.754-826.0	Seal, Crankshaft	1
17	8.754-845.0	Washer, Copper G1/4 (16mm Models)	1	36	8.754-844.0	Flange, Motor	1
18	8.754-854.0	Bolt, Manifold M14 X 40	2	37	9.803-210.0	Washer	10
				38	8.752-824.0	Screw, 6 mm	4

LF 2030S SERIES PUMP PARTS LIST

ITEM	PART NO.	DESCRIPTION	QTY
39*	8.754-855.0	Bolt, Plunger	3
40*	8.754-092.0	Spacer, Copper	3
41	8.754-848.0	Plunger, 16mm	3
42	9.803-962.0	Spacer, Copper	3
43	8.754-827.0	Plunger Rod	3
44	9.803-965.0	Connecting Rod Pin	3
45	9.803-966.0	Connecting Rod	3
46	8.933-020.0	Screw, Connecting Rod	6
47	8.754-847.0	O-ring Ø2.62 X 111.62	1
48	8.754-842.0	Cover, Crankcase	1
49	9.803-906.0	O-ring Ø1.78 X 14	1
50	9.803-202.0	Sight Glass, G3/4	1

REPAIR KIT NUMBER	8.754-860.0	8.754-856.0	8.754-861.0	8.754-857.0	8.754-862.0	8.754-858.0	8.754-859.0	9.803-937.0
KIT DESCRIPTION	Plunger Seals 14 mm**	Plunger Seals 16 mm**	Seal Packing 14 mm**	Seal Packing 16 mm**	Plunger 14 mm**	Plunger 16 mm**	Complete Valve	Plunger Oil Seals
ITEM NUMBERS INCLUDED	4, 6, 8	4, 6, 8	4, 5, 6, 7, 8	4, 5, 6, 7, 8	39, 40, 41, 42	39, 40, 41, 42	12, 13, 14	3

VRT3 UNLOADER EXPLODED VIEW AND PART S LIST

8.750-299.0, 8 GPM, 4500 PSI

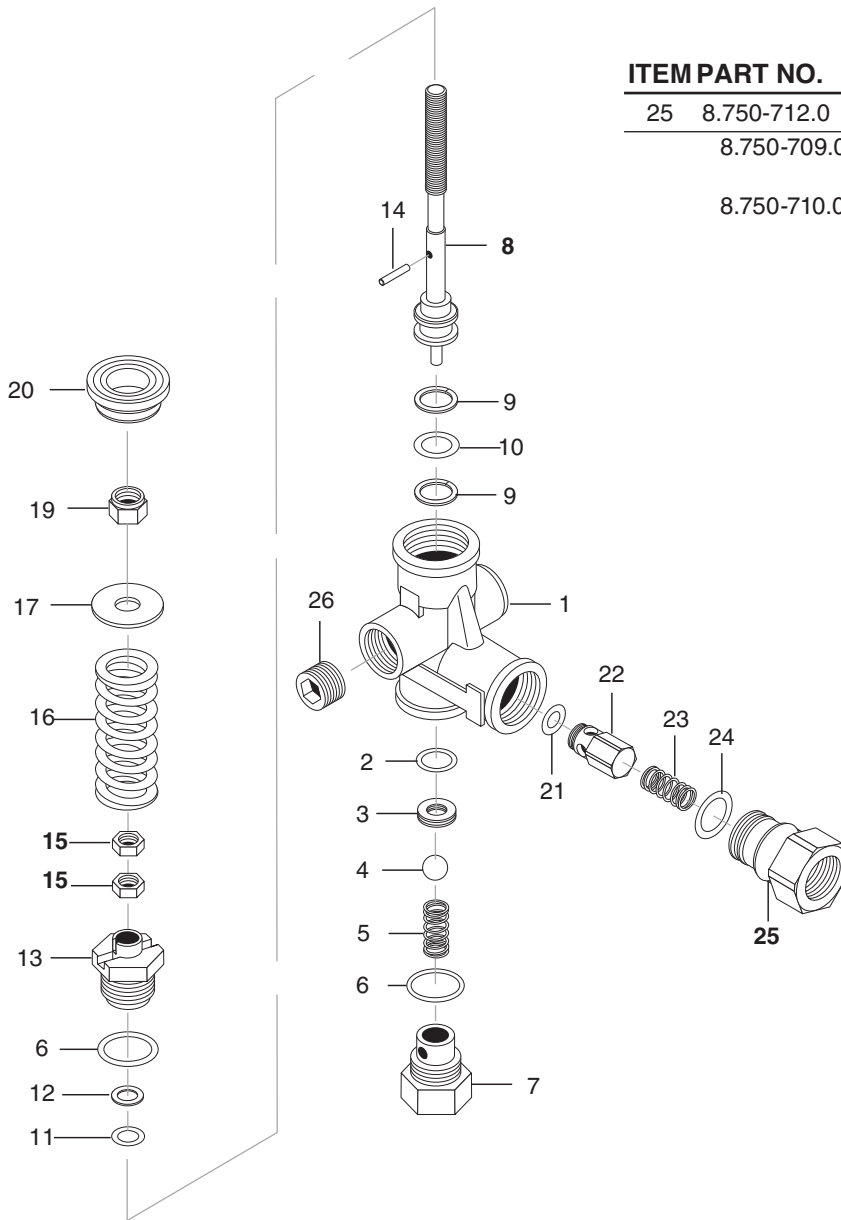

ITEM	PART NO.	DESCRIPTION	QTY
25	8.750-712.0	Outlet Fitting	1
	8.750-709.0	Repair Kit, VRT3, 2320/3630 PSI	
	8.750-710.0	Repair Kit, VRT3, 4500 PSI (Kit Items: 1, 4, 8-12, 16, 21-22)	

Unloader Adjustment Procedures

1. Remove lock nut (Item 19).
2. Remove adjustment knob (Item 18).
3. Loosen the two (2) nuts (Item 15), move them upward on stem (Item 8) until you see 4 or more threads below the nut.
4. Re-attach adjusting knob (Item 18).
5. Start machine. Open the trigger of the spray gun. Increase pressure by turning adjustment knob (Item 18) clockwise until pressure is at the desired operating pressure.
6. Remove the adjustment knob (Item 18), tighten the lower nut (Item 15) tightly against the upper nut (Item 15). Reattach adjustment knob (Item 18) and screw down until contact is made with the nuts (Items 15). Screw down lock nut (Item 19) onto the stem (Item 8) until the threads cut into the nylon insert of the lock nut (Item 19).

*If adjustment knob (Item 18) DOES NOT make contact with upper nut (Items 15), remove adjusting knob (Item 18), re-adjust (raise) nuts (Items 15) on stem (Item 8) and re-attach adjustment knob (Item 18), then repeat step #6.

**If adjustment knob (Item 18) DOES make contact with upper nut; release the trigger of the spray gun and watch the pressure gauge for the pressure increase ("spike"). This "spike" SHOULD NOT exceed 500 psi above the operating pressure. If "spike" pressure exceeds the 500 psi limit, remove the adjusting knob (Item 18) and re-adjust (lower) the nuts (Items 15) on the stem (Item 8).

Re-attach the adjusting knob (Item 18), then repeat step #6.

WIRING DIAGRAM

1.106-160.0 HD 2.0/1000 Dual Mister

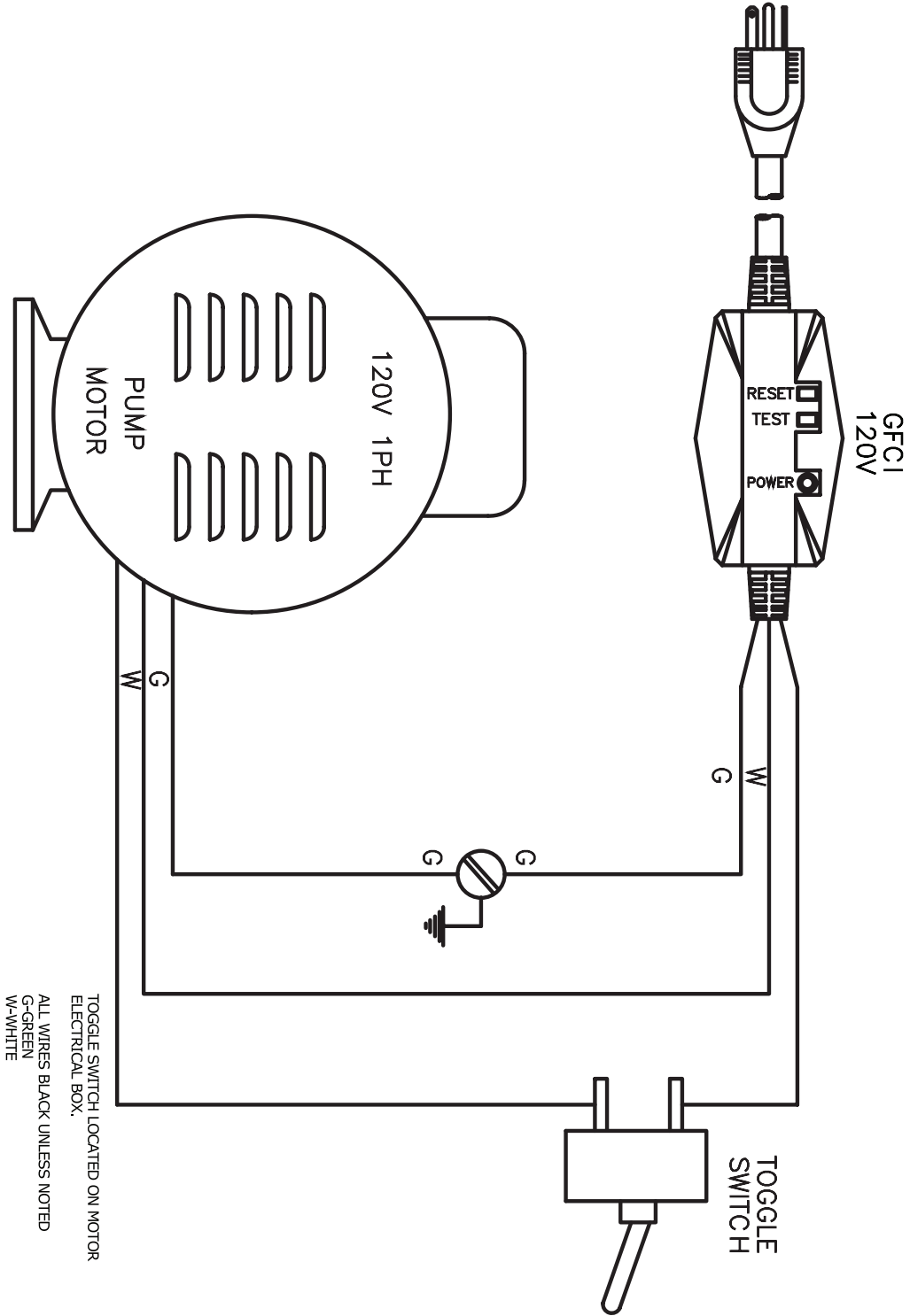

TROUBLESHOOTING

PROBLEM	POSSIBLE CAUSE	SOLUTION
PUMP RUNNING NORMALLY BUT PRESSURE LOW ON INSTALLATION	Pump sucking air	Check water supply and possibility of air seepage.
	Check valves sticking	Check and clean or replace if necessary.
	Unloader valve seat faulty	Check and replace if necessary.
	Nozzle incorrectly sized	Check and replace if necessary.
	Worn piston packing	Check and replace if necessary.
FLUCTUATING PRESSURE	Valves worn	Check and replace if necessary.
	Blockage in valve	Check and replace if necessary.
	Pump sucking air	Check water supply connections.
	Worn piston packing	Check and replace if necessary.
	Insufficient water	Check filter and hose for breakage.
PRESSURE LOW AFTER PERIOD OF NORMAL USE	Nozzle worn	Check and replace if necessary.
	Suction or delivery valves worn	Check and replace if necessary.
	Suction or delivery lines blocked	Check and clean if necessary.
	Unloader valve seat worn	Check and replace if necessary.
	Worn piston packing	Check and replace if necessary.
	Water temperature excessive	Reduce to below 160° F.
PUMP NOISY	Air in suction line	Check water supply and connections on suction line.
	Broken or weak suction or delivery valve spring	Check and replace if necessary.
	Foreign matter in valves	Check and clean if necessary.
	Worn bearings	Check and replace if necessary.
	Excessive temperature of water	Reduce to below 160° F.
PRESENCE OF WATER IN PUMP OIL	Oil seal worn	Check and replace if necessary.
	High humidity in air	Check and replace if necessary.
	Piston packing worn	Check and replace if necessary.
WATER DRIPPING FROM UNDER PUMP	Piston packing worn	Check and replace if necessary.
	O-ring plunger retainer worn	Check and replace if necessary.
WATER DRIPPING FROM PUMP PROTECTOR	Water supply pressure too high (over 90 PSI)	Lower water supply pressure using a regulator.
	Spray gun is in the off position for over 5 minutes	Turn machine off if not in use for over 1-2 minutes.
OIL DRIPPING	Oil seal worn	Check and replace if necessary.
EXCESSIVE VIBRATION IN HIGH PRESSURE HOSE	Irregular functioning of the pump valves	Check and replace if necessary.
MOTOR DOES NOT START WHEN SWITCHED ON	Plug not well connected or lack of power supply	Check plug, cable and switch.
WHEN SWITCHING ON THE MACHINE, MOTOR HUMS BUT DOES NOT RUN	Main voltage is insufficient, lower than the minimum required	Check to make sure main power supply is adequate.
	The pump is stuck or frozen	Check by turning the motor manually.
MOTOR STOPS	Tripped thermal overload due to overheating	Check that main voltage corresponds to the specifications. Wait a few minutes before turning on the machine again by resetting the GFCI cord.

PREVENTATIVE MAINTENANCE

PREVENTATIVE MAINTENANCE

This pressure washer was produced with the best available materials and quality craftsmanship. However, you as the owner have certain responsibilities for the correct care of the equipment. Attention to regular preventative maintenance procedures will assist in preserving the performance of your equipment. Contact your dealer for maintenance. Regular preventative maintenance will add many hours to the life of your pressure washer. Perform maintenance more often under severe conditions.

MAINTENANCE SCHEDULE		
Pump Oil (Non foaming) SAE 10W-40	Inspect	Daily inspect the oil level
	Change	After first 50 hours, then every 500 hours or annually
Replace High Pressure Nozzle		Every 6 months
Replace Quick Connects		Annually
Clean Water Screen/Filter		Weekly
Replace HP Hose		Annually if there is any sign of wear
Grease Motor		Every 10,000 hours

OIL CHANGE RECORD

Check pump oil and engine oil level before first use of your new pressure washer.

Date Oil Changed Month/Day/Year	Estimated Operating Hours Since Last Oil Change	Date Oil Changed Month/Day/Year	Estimated Operating Hours Since Last Oil Change



THANK YOU!
MERCI! DANKE! ¡GRACIAS!



Registrieren Sie Ihr Produkt und profitieren Sie von vielen Vorteilen.

Register your product and benefit from many advantages.

Enregistrez votre produit et bénéficiez de nombreux avantages.

Registre su producto y aproveche de muchas ventajas.

www.kaercher.com/welcome



Bewerten Sie Ihr Produkt und sagen Sie uns Ihre Meinung.

Rate your product and tell us your opinion.

Évaluer votre produit et dites-nous votre opinion.

Reseñe su producto y díganos su opinión.

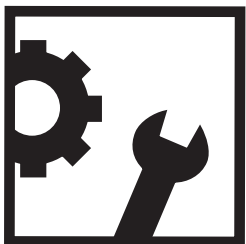

www.kaercher.com/dealersearch

Alfred Kärcher SE & Co. KG
Alfred-Kärcher-Str. 28-40
71364 Winnenden (Germany)
Tel.: +49 7195 14-0
Fax: +49 7195 14-2212

