

KÄRCHER

makes a difference

High pressure cleaner
Electric motor - Cold water

English..... 3
Español.... 20

MODELS:

1.106-160.0
HD 2.0/1000 Dual Mister

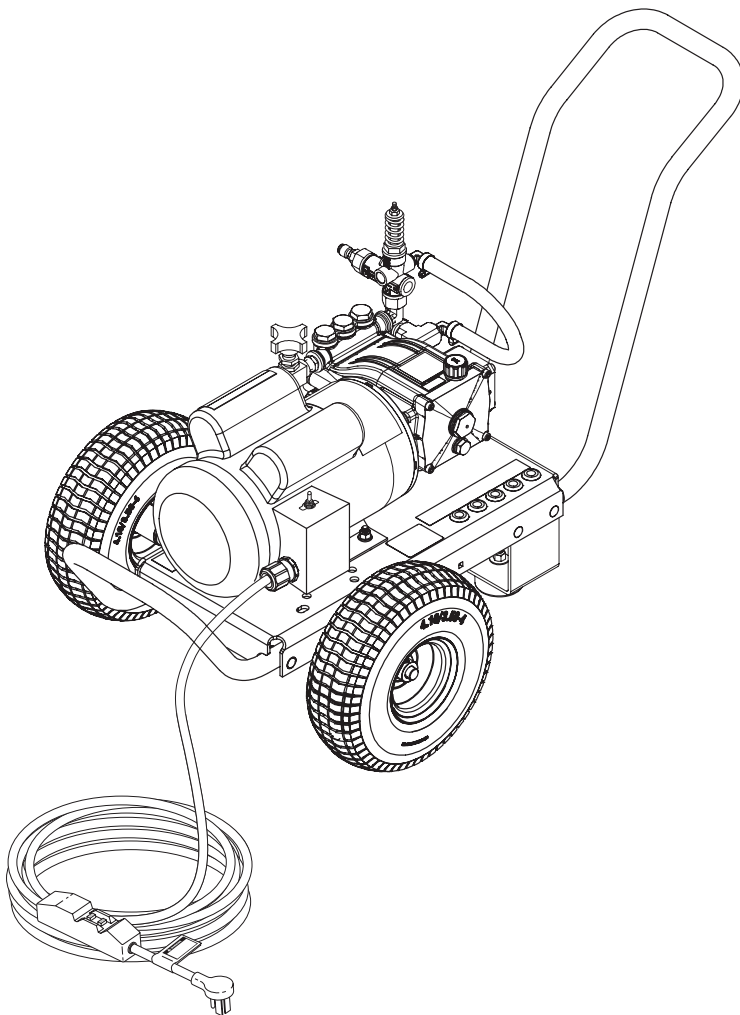

**Register
your product**
www.kaercher.com/welcome



9.808-246.0 - F (05/03/22)

Important Safety Information	4-5
Operating instructions for misting mode	6
Operating instructions for high pressure mode.....	7
Exploded View	8
Exploded View Parts List	9-10
Pump Assembly, Exploded view	11
Filter Exploded view.....	12
Cleaning The Water Inlet Filter	13
LF2030S Series Pump Exploded view and part's list	14-15
VRT3 Unloader exploded view and part's list	16
Wiring Diagram	17
Troubleshooting	18
Preventative Maintenance	19

Model Number _____

Serial Number _____

Date of Purchase _____

The model and serial numbers will be found on a decal attached to the pressure washer. You should record both serial number and date of purchase and keep in a safe place for future reference.

INTRODUCTION & IMPORTANT SAFETY INFORMATION

Thank you for purchasing this Pressure Washer.

We reserve the right to make changes at any time without incurring any obligation.

Owner/User Responsibility:

The owner and/or user must have an understanding of the manufacturer's operating instructions and warnings before using this pressure washer. Warning information should be emphasized and understood. If the operator is not fluent in English, the manufacturer's instructions and warnings shall be read to and discussed with the operator in the operator's native language by the purchaser/owner, making sure that the operator comprehends its contents.

Owner and/or user must study and maintain for future reference the manufacturers' instructions.

The operator must know how to stop the machine quickly and understand the operation of all controls. Never permit anyone to operate the engine without proper instructions.

SAVE THESE INSTRUCTIONS

This manual should be considered a permanent part of the machine and should remain with it if machine is resold.

When ordering parts, please specify model and serial number. Use only identical replacement parts.

This machine is to be used only by trained operators.

single phase this product should only be connected to a power supply receptacle protected by a GFCI.

DANGER: Improper connection of the equipment-grounding conductor can result in a risk of electrocution. Check with a qualified electrician or service personnel if you are in doubt as to whether the outlet is properly grounded. Do not modify the plug provided with the product - if it will not fit the outlet, have a proper outlet installed by a qualified electrician. Do not use any type of adaptor with this product

DANGER: Une mauvaise connexion du conducteur de terre de l'équipement peut entraîner un risque d'électrocution. Vérifier auprès d'un électricien qualifié ou du personnel d'entretien si vous avez des doutes quant à savoir si la sortie est correctement mise à la masse. Ne pas modifier la fiche fournie avec le produit - si elle n'entre pas dans la sortie, faire installer une sortie appropriée par un électricien qualifié. Ne jamais utiliser un adaptateur avec ce produit.



WARNING: Keep wand, hose, and water spray away from electric wiring or fatal electric shock may result.

DANGER: Garder la lance, le boyau et le jet d'eau à l'écart de tout câblage électrique ou des chocs électriques mortels pourraient survenir.

IMPORTANT SAFETY INFORMATION

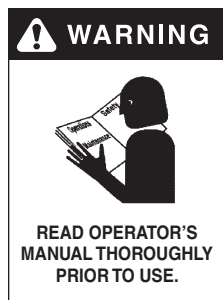

WARNING: To reduce the risk of injury, read operating instructions carefully before using.

AVERTISSEMENT: Pour réduire le risque de blessures, lire attentivement les instructions de fonctionnement avant l'utilisation.

1. Read the owner's manual thoroughly. Failure to follow instructions could cause malfunction of the machine and result in death, serious bodily injury and/or property damage.

2. Know how to stop the machine and bleed pressure quickly. Be thoroughly familiar with the controls.

3. Stay alert — watch what you are doing.

4. All installations must comply with local codes. Contact your electrician, plumber, utility company or the selling distributor for specific details. If your machine is rated 250 volts or less, single phase will be provided with a ground fault circuit interrupter (GFCI). If rated more than 250 volts, or more than



WARNING: Flammable liquids can create fumes which can ignite, causing property damage or severe injury.

AVERTISSEMENT: Des liquides inflammables peuvent produire des vapeurs qui peuvent s'enflammer, causant ainsi des dommages à la propriété ou des blessures graves.

WARNING: Risk of explosion — Do not spray flammable liquids.

AVERTISSEMENT: Risque d'incendie - Ne pas pulvériser de liquides inflammables.

6. Do not allow acids, caustic or abrasive fluids to pass through the pump.

IMPORTANT SAFETY INFORMATION

7. Never run pump dry or leave spray gun closed longer than 1-2 minutes.
8. Keep operating area clear of all persons.



WARNING: High pressure spray can cause paint chips or other particles to become airborne and fly at high speeds. To avoid personal injury, eye, hand and foot safety devices must be worn.

AVERTISSEMENT: Un jet haute-pression peut écailler la peinture ou provoquer l'émission d'autres particules dans l'air et leur projection à hautes vitesses. Pour éviter les lésions corporelles, une protection des yeux, du visage, des mains et des pieds doit être portée lors de l'utilisation de cet équipement.

9. Eye, hand, and foot protection must be worn when using this equipment.

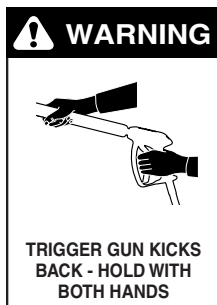

WARNING: Grip cleaning wand securely with both hands before starting. Failure to do this could result in injury from a whipping wand.

AVERTISSEMENT: Agripper la lance de nettoyage avec les deux mains avant de commencer. Le non-respect de cette consigne pourrait mener à des blessures

causées par le mouvement violent de la lance.



WARNING: High pressure developed by these machines will cause personal injury or equipment damage. Keep clear of nozzle. Use caution when operating. Do not direct discharge stream at people, or severe injury or death will result.

AVERTISSEMENT: La haute pression générée par ces machines causera des lésions corporelles ou des dommages à l'équipement. Se tenir à l'écart de la buse. Faire preuve de prudence lors de l'utilisation. Ne pas décharger directement le jet vers des personnes ou des animaux, car cela risquerait de causer des blessures graves ou même la mort.

10. To reduce the risk of injury, close supervision is necessary when a machine is used near children. Do not allow children to operate the pressure washer. **This machine must be attended during operation.**
11. Never make adjustments on machine while in operation.

12. Be certain all quick coupler fittings are secured before using pressure washer.



WARNING: Protect machine from freezing.

AVERTISSEMENT: Protéger la machine contre le gel.

13. To keep machine in best operating conditions, it is important you protect machine from freezing. Failure to protect machine from freezing could cause malfunction of the machine and result in death, serious bodily injury, and/or property damage. Follow storage instructions specified in this manual.

14. Inlet water must be clean fresh water and no hotter than 90°F.
15. Manufacturer will not be liable for any changes made to our standard machines or any components not purchased from us.
16. The best insurance against an accident is precaution and knowledge of the machine.



WARNING: Be extremely careful when using a ladder, scaffolding or any other relatively unstable location. The cleaning area should have adequate slopes and drainage to reduce the possibility of a fall due to slippery surfaces.

AVERTISSEMENT: Une modification non autorisée de la machine ou l'utilisation de pièces de rechange non approuvées peut causer des lésions corporelles et/ou des dommages à la propriété, et annulera la garantie du fabricant.

17. Do not overreach or stand on unstable support. Keep good footing and balance at all times.
18. Do not operate this machine when fatigued or under the influence of alcohol, prescription medications, or drugs.

WARNING: Do not spray machine or any people, animals or electrical parts.



AVERTISSEMENT: Ne pas vaporiser sur la machine ou les gens, les animaux ou les pièces électriques.



Follow the maintenance instructions specified in the manual.

OPERATING INSTRUCTIONS FOR MISTING MODE

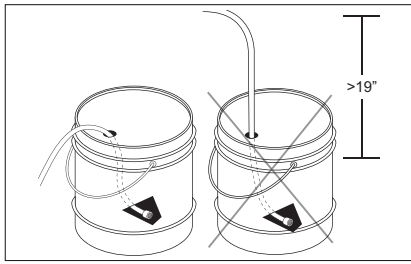

STEP 1: Attach ½” hose to a disinfectant bucket (Recomendable that water inlet is at floor level). We recommend Vital Oxide.

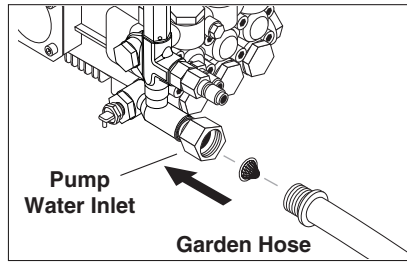

STEP 2: Connect ½” hose to pump Water inlet. Inspect inlets.

CAUTION: Do not run the pump without water or pump damage will result.

ATTENTION: Ne pas faire fonctionner la pompe sans eau pour éviter d'endommager la pompe.

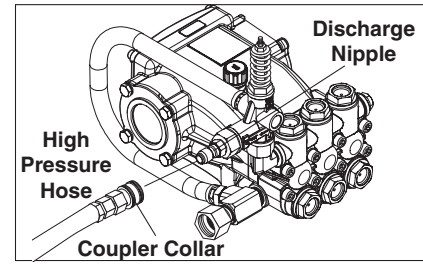

STEP 3: Connect ¼” high pressure hose to the discharge nipple. Push coupler collar forward until secure.

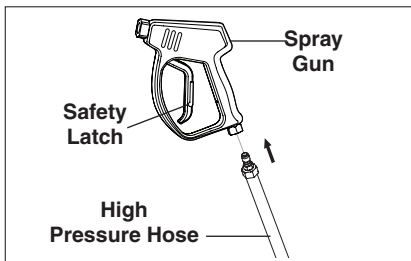

STEP 4: Attach the high pressure hose to the spray gun.

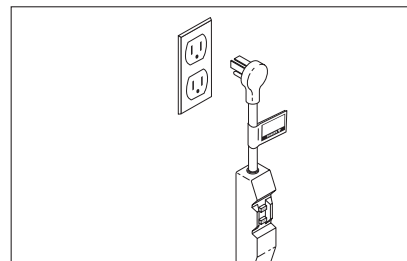

STEP 5: Connect to appropriate power supply. Push reset button on GFCI.

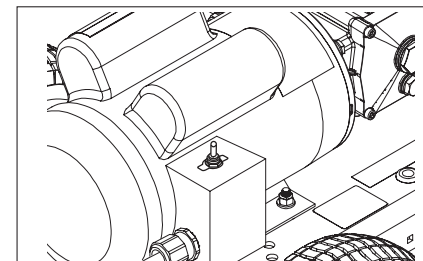

STEP 6: Start up the machine.

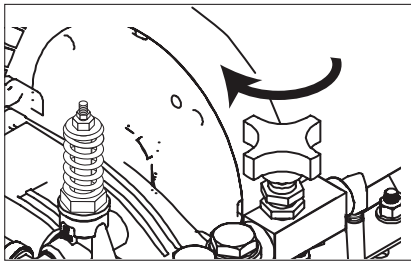

STEP 7: Close metering valve to purge hose.

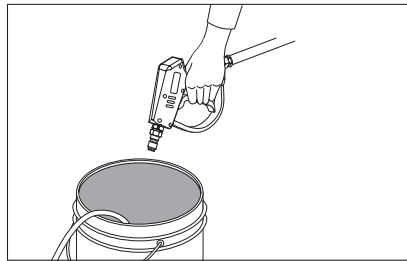

STEP 8: Purge any air trapped in hose (Recommend to do this over the disinfectant bucket).

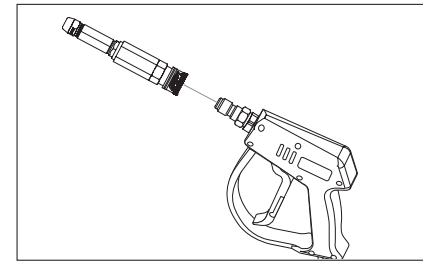

STEP 9: Attach misting nozzle into the spray gun.

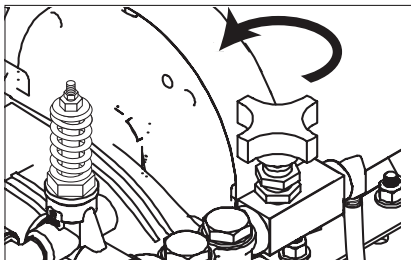

STEP 10: Open metering valve to use Misting mode.

CAUTION: If valve stays close in misting mode nozzle may get damage.

ATTENTION: Si la soupape reste fermée en mode brumisation, la buse peut être endommagée.

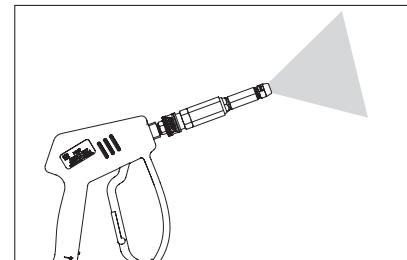

STEP 11: Ready to use, mist Vital Oxide disinfectant.

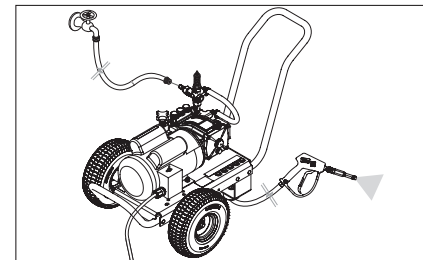

IMPORTANT: After finish the job, flush all chemical remains from the unit. Fill tank with fresh water and flush all system.

IMPORTANT: Une fois le travail terminé, rincer tous les restes chimiques de l'unité. Remplir le réservoir d'eau douce et rincer tout le système.

OPERATING INSTRUCTIONS FOR HIGH PRESSURE MODE

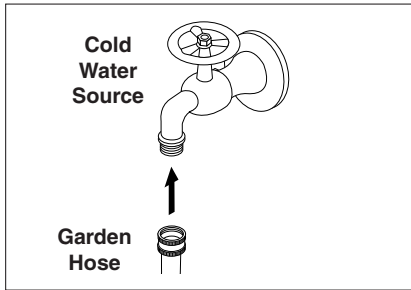

STEP 1: Connect 1/2" hose to cold water inlet.

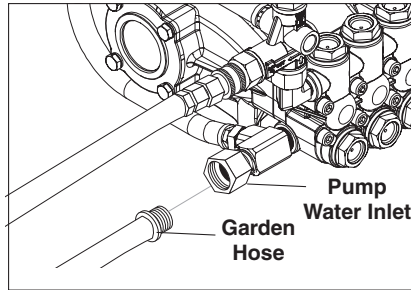

STEP 2: Check inlets filters, remove debris, then connect the garden hose to pump water inlet.

CAUTION: Do not run the pump without water or pump damage will result.

ATTENTION: Ne pas faire fonctionner la pompe sans eau pour éviter d'endommager la pompe.

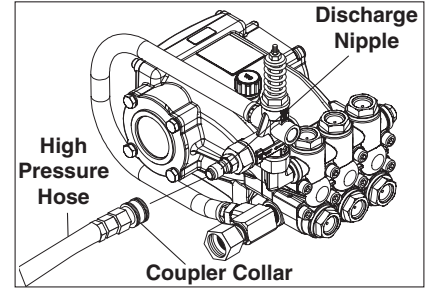

STEP 3: Connect 1/4" high pressure hose to the discharge nipple. Push coupler collar forward until secure.

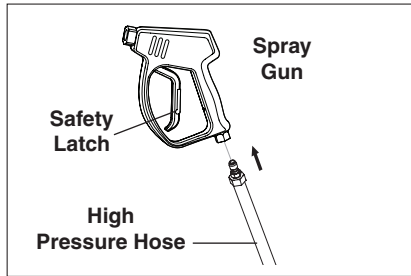

STEP 4: Attach the high pressure hose to the spray gun.

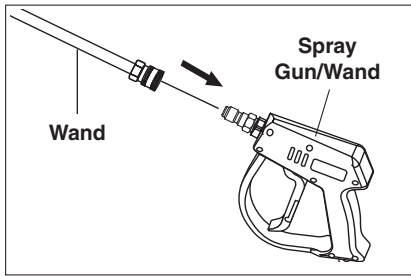

STEP 5: Attach wand to spray gun.

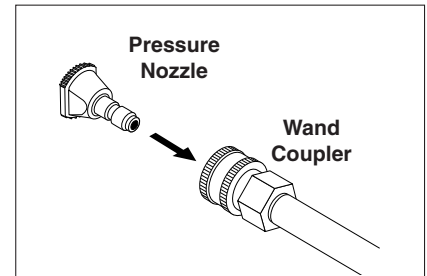

STEP 6: Pull spring-loaded collar of the wand coupler back to insert your choice of pressure nozzle.

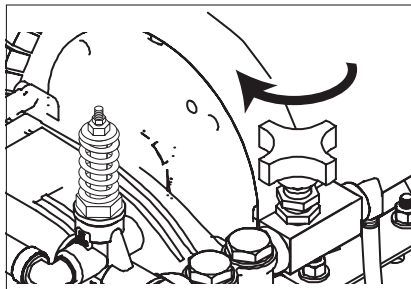

STEP 7: Close metering valve to purge hose.

CAUTION: If valve is open, pressure wont reach rate.

ATTENTION: Si la soupape est ouverte, la pression n'atteindra pas le taux.

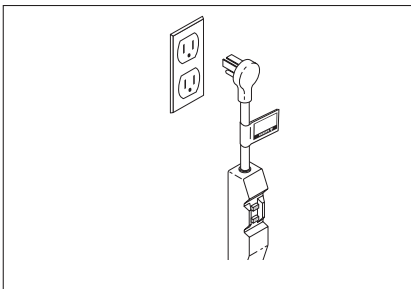

STEP 8: Connect to appropriate power supply. Push reset button on GFCI.

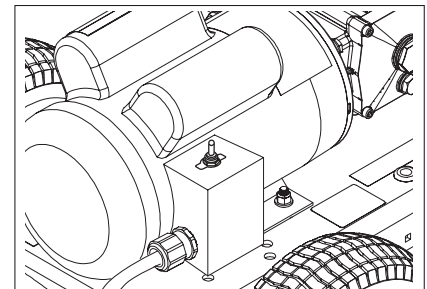

STEP 9: Start up the machine.

EXPLODED VIEW

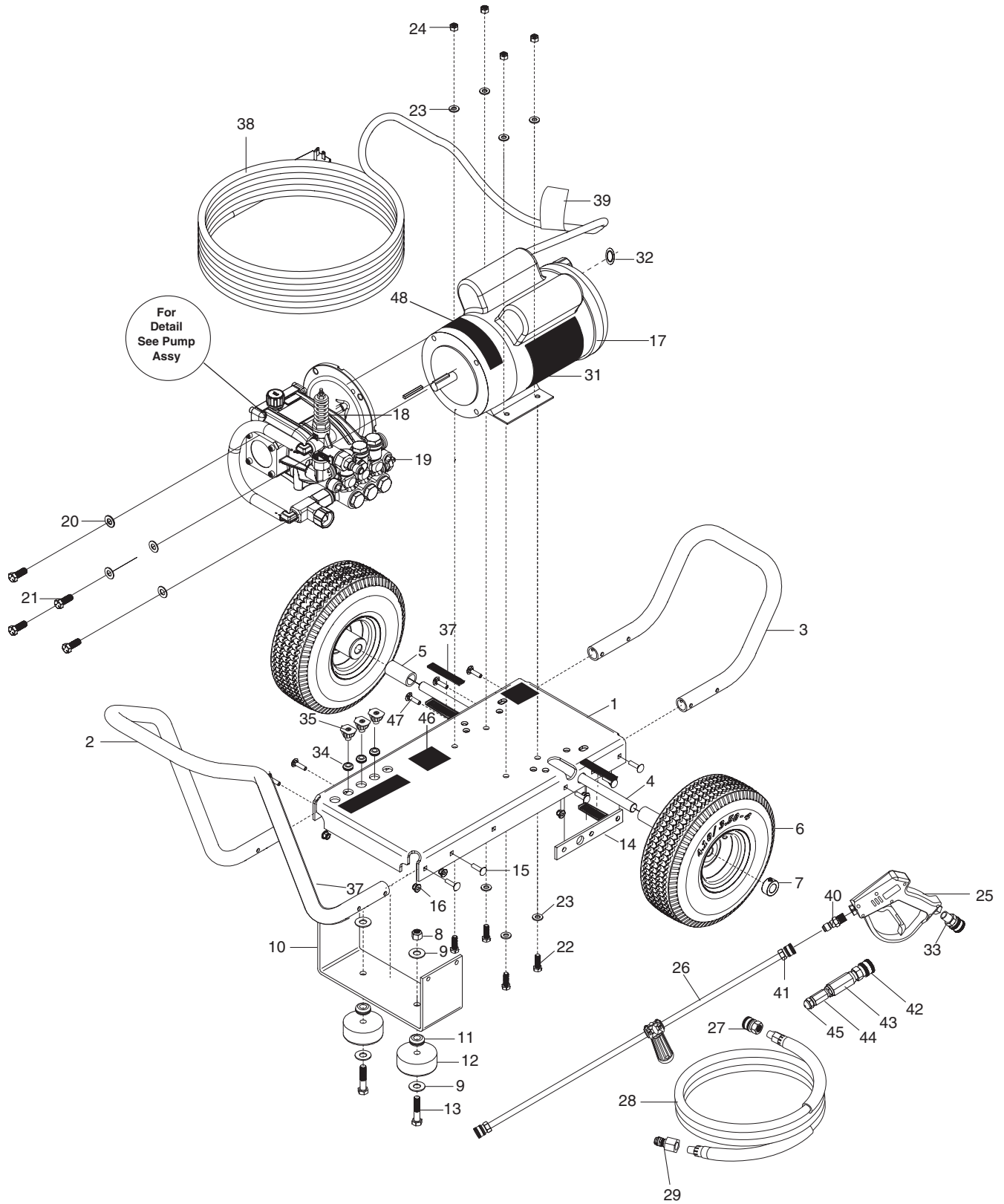

EXPLODED VIEW PARTS LIST

ITEM	PART NO.	DESCRIPTION	QTY
1	8.924-115.0	Al Base Direct Drive	1
2	8.924-394.0	Al Handle	1
3	8.924-393.0	Al Bumper	1
4	9.803-097.0	Axle, 5/8 X 20.125 Long	1
5	8.924-179.0	AL Spacer Tube DD Frame	2
6	8.756-365.0	QH Wheel Assy 10", Gray STL RIM, Flat	1
7	9.802-782.0	Collar, 5/8" Bore Shaft 3010	2
8	9.197-003.0	3/8-16 NE Nylon Insert L/N ZC 5UM White	2
9	9.802-817.0	Washer, 3/8" x 1"	4
10	8.924-116.0	Foot AL DD Frame CW	1
11	9.802-064.0	Grommet, Rubber, Nozzle Holder	2
12	9.802-066.0	Pad Soft Rubber	2
13	9.196-041.0	Hex Head Bolt 3/8-16 X 1-3/4	2
14	8.924-074.0	Camaro Silver Axle Holder DD CW	1
15	9.802-706.0	Bolt, 1/4"-20 x 1-3/4" Carriage Zinc	8
16	9.197-010.0	1/4-20" Nylon Insert Lock Nut With Flange	10
17	9.804-516.0	Motor, 1.5HP 1PH, 115V 1725RPM, TEFC	1
18	8.750-299.0	Unloader, VRT3, 8 GPM @4500 PSI	1
19	8.754-761.0	Pump, Leuco LF2030S, 2.1@3000, 1725RPM	1
20	9.198-004.0	3/8", USS F/W Zinc	4
21	9.802-720.0	Bolt, 3/8" x 1", NC HH	4
22	9.802-710.0	Screw 5/16" x 1" NC	4
23	8.718-980.0	Washer, 5/16" Flat, SAE	8
24	9.802-776.0	Nut, 5/16-18, ESNA	4
25	8.750-247.0	Trigger Gun Model m407	1
26	8.783-039.0	Wand 30" Zinc Plated, Handle & Coupler	1
27	9.802-166.0	Coupler, 3/8" Socket, Female, Brass	2
28	8.925-393.0	Hose 1/4"x75' 4000 PSI SWxSW CPL S120	1
29	9.802-170.0	Coupler, 3/8" Plug, Female, Steel Zinc	1
30	8.900-305.0	Label, Landa, Home Depot, ZE Warning	1
31	9.800-037.0	Label, French Inst./Warn	1
32	9.803-834.0	Washer, Reducing 3/4" x 1/2"	1
33	9.802-169.0	Coupler, 3/8"Socket, Male, Brass	1
34	8.755-187.0	Grommet, Rubber, Nozzle Holder Base 3/16	5
35	8.712-338.0	Nozzle, SAQCMEG 1503.5, Yellow	1
	8.712-339.0	Nozzle, SAQCMEG, 2503.5, Green	1
	8.712-340.0	Nozzle, SAQCMEG 4003.5, White	1
36	9.800-016.0	Label, Disconnect Power Supply	1
37	8.755-210.0	Four Nozzle Label, Black	1
38	9.802-432.0	GFCI, 120V 15A, W/ 36' 12-3 CORD	1
39	8.932-969.0	Label, Warning, Service Cord	1
40	8.707-139.0	Coupler, 1/4"Plug, Male, Steel/Zinc	1
41	9.802-164.0	Coupler, 1/4"Socket, Female, Brass	1
42	8.756-030.0	Coupler, 1/4 Socket, Male, Brass	1
43	8.709-175.0	Filter,High Pressure 1/4"Npt-Fx1/4"Np	1
44	8.758-918.0	Adapter 9/16 X 1/4	1
45	8.756-697.0	Fuel Nozzle, 2.50 X 80 BZ	1
46	9.800-049.0	Label, Manufacturer's cleaning solution	1
47	8.757-432.0	Bolt, 1/4-20 X 3/4,Carriage ST CL5 ZNPLT	2

PUMP ASSEMBLY EXPLODED VIEW

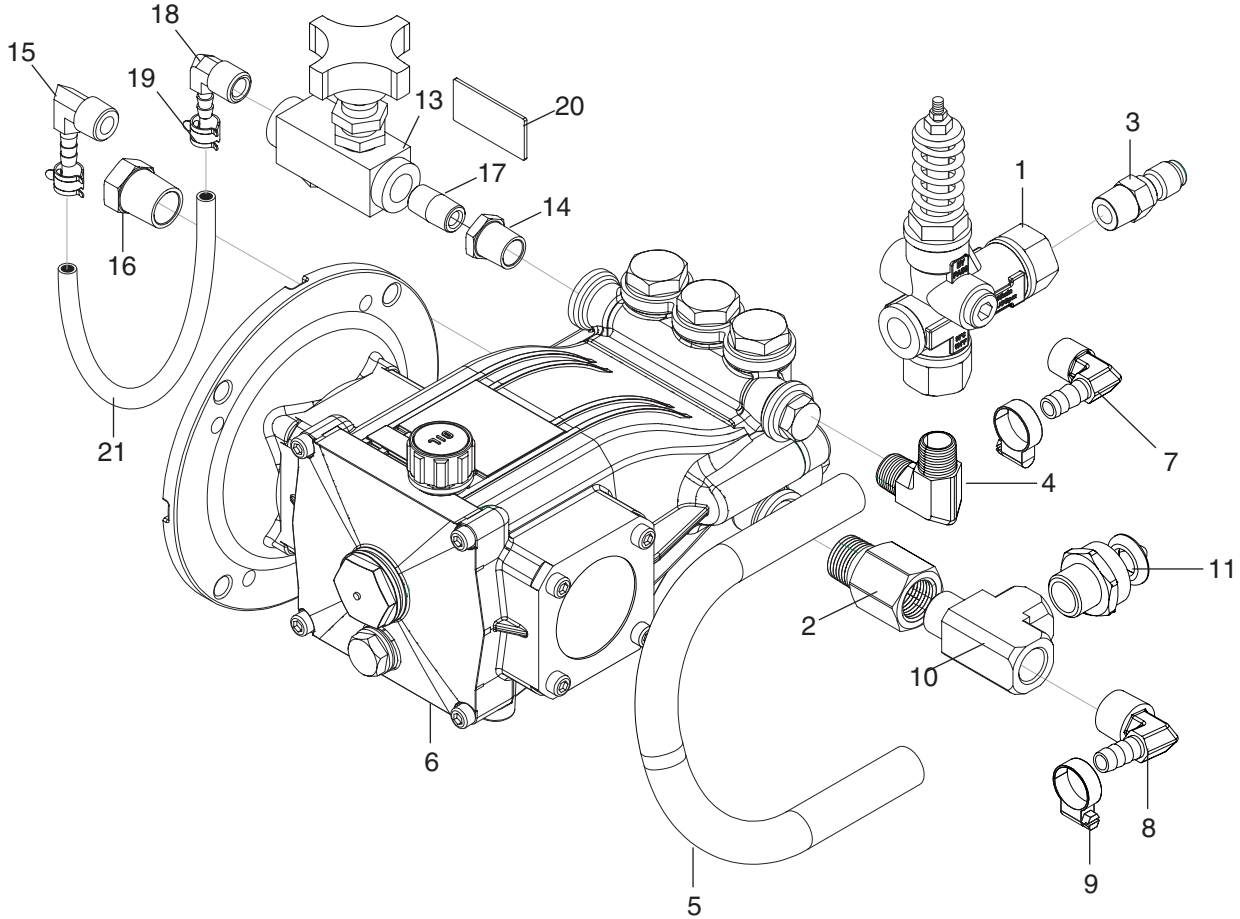

PUMP ASSY EXPLODED VIEW PARTS LIST

ITEM	PART NO.	DESCRIPTION	QTY	ITEM	PART NO.	DESCRIPTION	QTY
1	8.750-299.0	Unloader, Vrt3, 8 Gpm @4500 Psi	1	13	8.707-317.0	Valve, Flow Control	1
2	8.757-193.0	Adapter, 1/2" F-Nptf X 1/2" M-Nptf, Brass	1	14	8.706-297.0	Bushing, 3/8" X 1/4" Steel Yellow Chrom	1
3	8.707-152.0	Nipple, 3/8", Male, Ssteel	1	15	8.706-965.0	Hose Barb, 1/4" Barb X 3/8" Npt-M, 90	1
4	8.759-036.0	Elbow Stainless Steel 3/8" NPTF	1	16	8.706-294.0	Bushing, 1/2" X 3/8", Steel P/N-5406-	1
5	8.711-785.0	Hose, 3/8 Push On	1	17	8.757-337.0	Nipple, 1/4" Close Sch 80 Steel, W/SInt	1
6	8.758-069.0	Pump LEUCO LFP2030S, 2.1 @3000, 1725RPM	1	18	8.757-205.0	Hose Barb, 1/4" Barb X 1/4" M-Nptf, 90	1
7	8.705-119.0	Hose Barb, Elbow, 3/8"Barbx3/8"Mpt/90Deg	1	19	6.390-126.0	Clamp Hose	2
8	8.758-199.0	Hose Barb Elbow 3/8"X1/2" 90 Deg W/SInt	1	20	8.758-919.0	Label Valve Label.	1
9	8.623-315.0	Clamp, 3/8 Hose (D-Slot)	2	21	9.802-254.0	Hose, 1/4 Push-On	5"
10	8.757-257.0	Tee, Street 1/2"	1				
11	8.757-203.0	Swivel, 1/2" M-Nptf X 3/4" Ghf	1				
12	9.804-016.0	Filter Screen Washer, Garden Hose/30Mesh	1				

FILTER EXPLODED VIEW

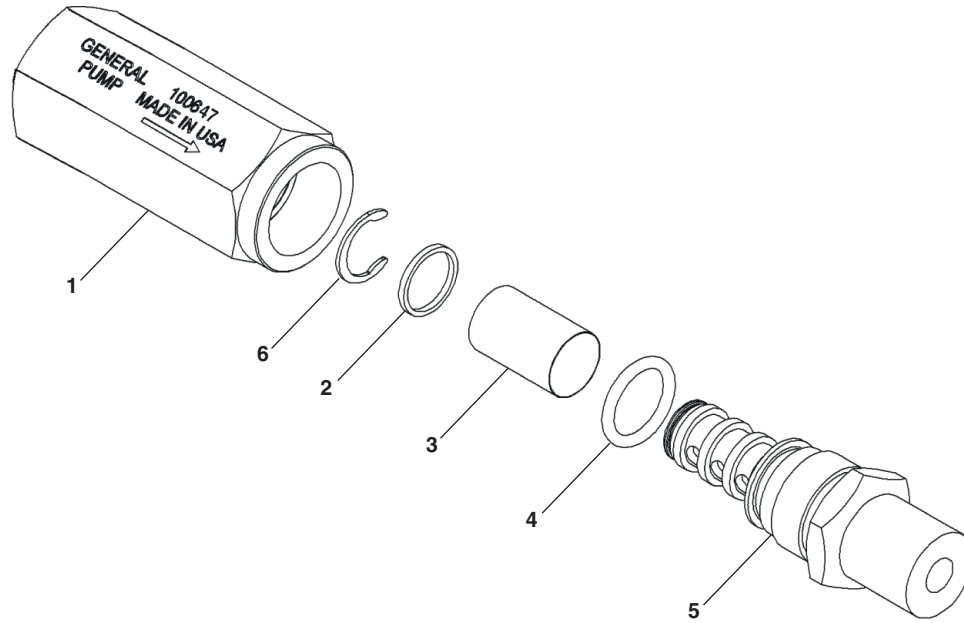

FILTER PARTS LIST

ITEM	DESCRIPTION	QTY
1	Housing, Nozzle Filter, 1/4 NPT-F	1
2	Retainer, Filter	1
3	Screen, 100 Mesh, T304SS	1
4	O-Ring, 70 Duro, Buna-N, .426 ID x .070 CS	1
5	Outlet Fitting, Nozzle Filter, 1/4 NTP-M	1
6	Retainer, External, SS	1

CLEANING THE WATER INLET FILTER

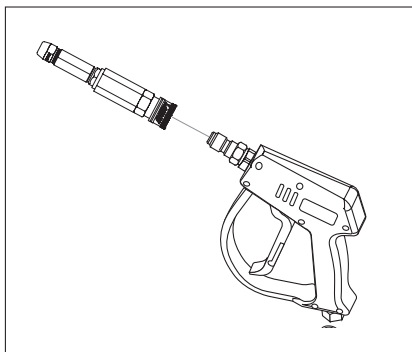

STEP 1: Disconnect Spray nozzle
From the machine

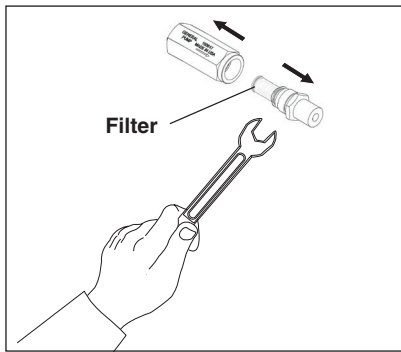

STEP 2: Pull out water inlet filter.
Use the necessary tools.

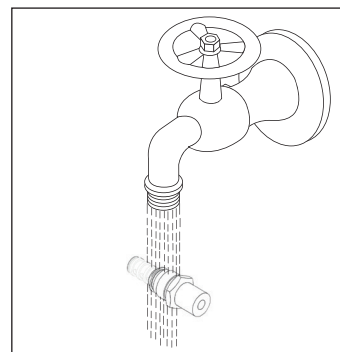

STEP 3: Rinse out water
inlet filter in warm water.

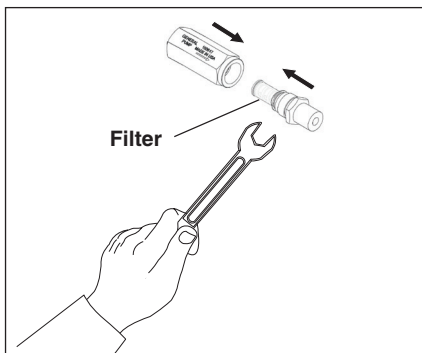

STEP 4: Assemble the water inlet
filter. Use the necessary tools.

LF 2030S SERIES PUMP EXPLODED VIEW

8.924-736.0 LF 2030S

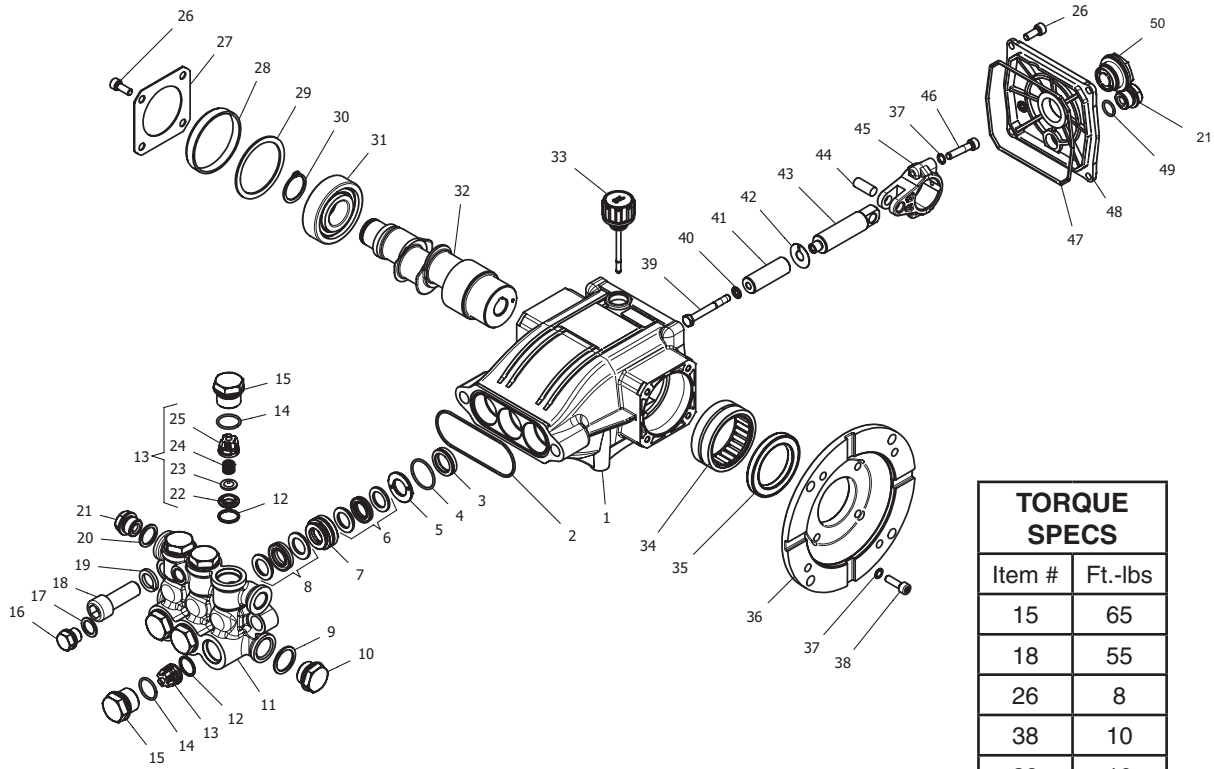

TORQUE SPECS	
Item #	Ft.-lbs
15	65
18	55
26	8
38	10
39	10
46	10

HF 2030S SERIES PUMP PARTS LIST

ITEM	PART NO.	DESCRIPTION	QTY	ITEM	PART NO.	DESCRIPTION	QTY
1	8.754-841.0	Crankcase	1	19	8.754-850.0	Washer, Lock	2
2	8.754-846.0	O-ring Ø1.78 X 72.75	1	20	9.803-198.0	Washer, Copper G3/8	1
3*	See Kits Below Plunger Oil Seal		3	21	8.707-262.0	Plug, Brass G3/8	2
4*	See Kits Below O-ring Ø1.78 X 26.7		3	22*	See Kits Below Valve Seat		6
5*	See Kits Below Washer, Pressure Ring		3	23*	See Kits Below Valve Plate		6
6*	See Kits Below U-Seal		3	24*	See Kits Below Valve Spring		6
7*	See Kits Below Pressure Ring		3	25*	See Kits Below Valve Cage		6
8*	See Kits Below U-Seal		3	26	9.802-939.0	Screw, M6 X 16	8
9	9.803-199.0	Washer, Copper G1/2	1	27	8.717-137.0	Bearing Cover	1
10	9.802-926.0	Plug, Brass G1/2	1	28	9.803-954.0	Bearing Seal	1
11	8.754-852.0	Manifold (16mm Models)	1	29	8.754-843.0	Seal Spacer, Crankshaft	1
	8.754-853.0	Manifold (14mm Models)	1	30	9.802-914.0	Snap Ring, 25 mm	1
12*	8.717-233.0	O-ring Ø1.78 X 15.6	6	31	9.803-955.0	Bearing, Ball	1
13*	See Kits Below Valve Assembly		6	32	8.754-836.0	Shaft, 5/8" Hollow	1
14*	9.803-948.0	O-ring Ø1.78 X 18.77	6	33	8.754-219.0	Oil Dipstick	1
15	9.803-949.0	Valve Plug	6	34	8.754-840.0	Bearing Needle	1
16	8.754-851.0	Plug, Brass G1/4 (16mm)	1	35	8.754-826.0	Seal, Crankshaft	1
17	8.754-845.0	Washer, Copper G1/4 (16mm Models)	1	36	8.754-844.0	Flange, Motor	1
18	8.754-854.0	Bolt, Manifold M14 X 40	2	37	9.803-210.0	Washer	10
				38	8.752-824.0	Screw, 6 mm	4

LF 2030S SERIES PUMP PARTS LIST

ITEM	PART NO.	DESCRIPTION	QTY
39*	8.754-855.0	Bolt, Plunger	3
40*	8.754-092.0	Spacer, Copper	3
41	8.754-848.0	Plunger, 16mm	3
42	9.803-962.0	Spacer, Copper	3
43	8.754-827.0	Plunger Rod	3
44	9.803-965.0	Connecting Rod Pin	3
45	9.803-966.0	Connecting Rod	3
46	8.933-020.0	Screw, Connecting Rod	6
47	8.754-847.0	O-ring Ø2.62 X 111.62	1
48	8.754-842.0	Cover, Crankcase	1
49	9.803-906.0	O-ring Ø1.78 X 14	1
50	9.803-202.0	Sight Glass, G3/4	1

REPAIR KIT NUMBER	8.754-860.0	8.754-856.0	8.754-861.0	8.754-857.0	8.754-862.0	8.754-858.0	8.754-859.0	9.803-937.0
KIT DESCRIPTION	Plunger Seals 14 mm**	Plunger Seals 16 mm**	Seal Packing 14 mm**	Seal Packing 16 mm**	Plunger 14 mm**	Plunger 16 mm**	Complete Valve	Plunger Oil Seals
ITEM NUMBERS INCLUDED	4, 6, 8	4, 6, 8	4, 5, 6, 7, 8	4, 5, 6, 7, 8	39, 40, 41, 42	39, 40, 41, 42	12, 13, 14	3

VRT3 UNLOADER EXPLODED VIEW AND PART S LIST

8.750-299.0, 8 GPM, 4500 PSI

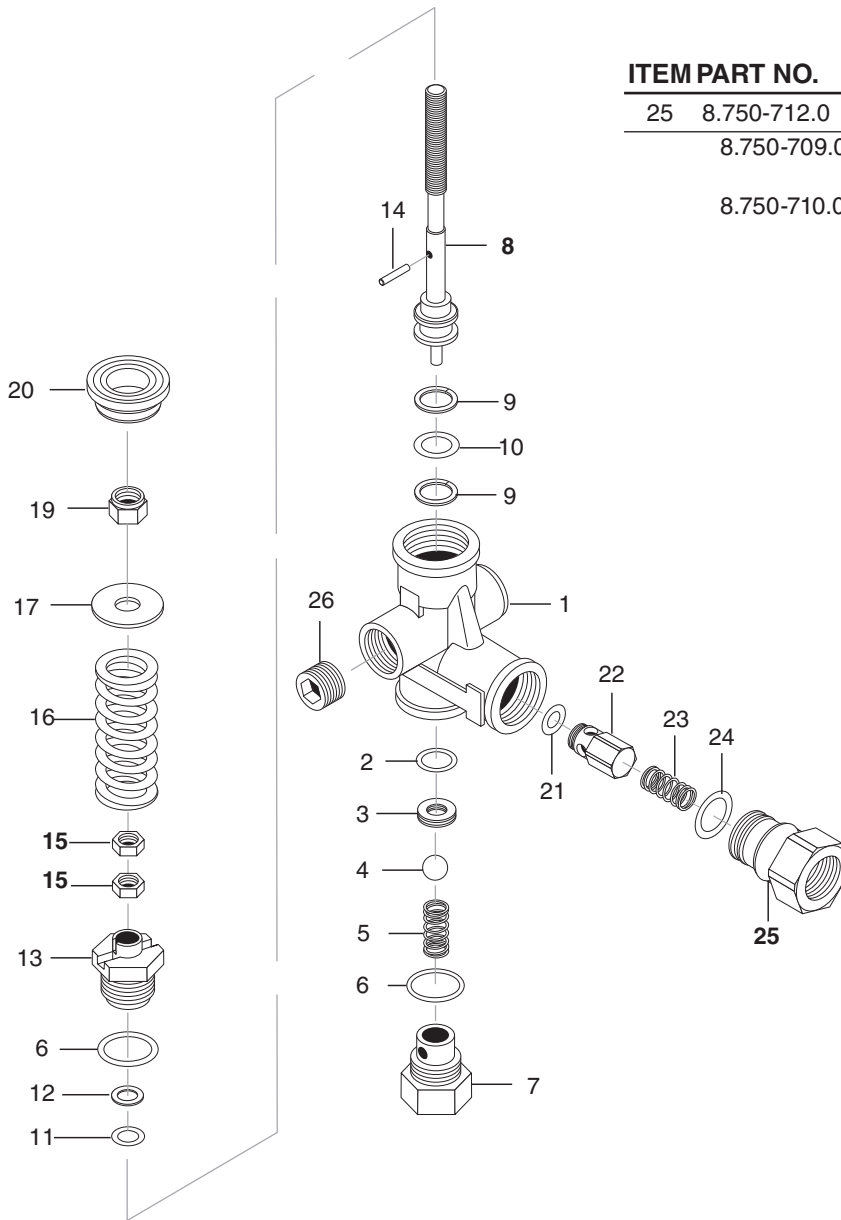

ITEM	PART NO.	DESCRIPTION	QTY
25	8.750-712.0	Outlet Fitting	1
	8.750-709.0	Repair Kit, VRT3, 2320/3630 PSI	
	8.750-710.0	Repair Kit, VRT3, 4500 PSI (Kit Items: 1, 4, 8-12, 16, 21-22)	

Unloader Adjustment Procedures

1. Remove lock nut (Item 19).
 2. Loosen the two (2) nuts (Item 15), move them upward on stem (Item 8) until you see 4 or more threads below the nut.
 3. Start machine. Open the trigger of the spray gun. Increase pressure by turning adjustment knob (Item 18) clockwise until pressure is at the desired operating pressure.
 4. Tighten the lower nut (Item 15) tightly against the upper nut (Item 15).
Screw down lock nut (Item 19) onto the stem (Item 8) until the threads cut into the nylon insert of the lock nut (Item 19).
- **Release the trigger of the spray gun and watch the pressure gauge for the pressure increase ("spike"). This "spike" SHOULD NOT exceed 500 psi above the operating pressure. If "spike" pressure exceeds the 500 psi limit, re-adjust (lower) the nuts (Items 15) on the stem (Item 8). Then repeat step #4.

WIRING DIAGRAM

1.106-160.0 HD 2.0/1000 Dual Mister

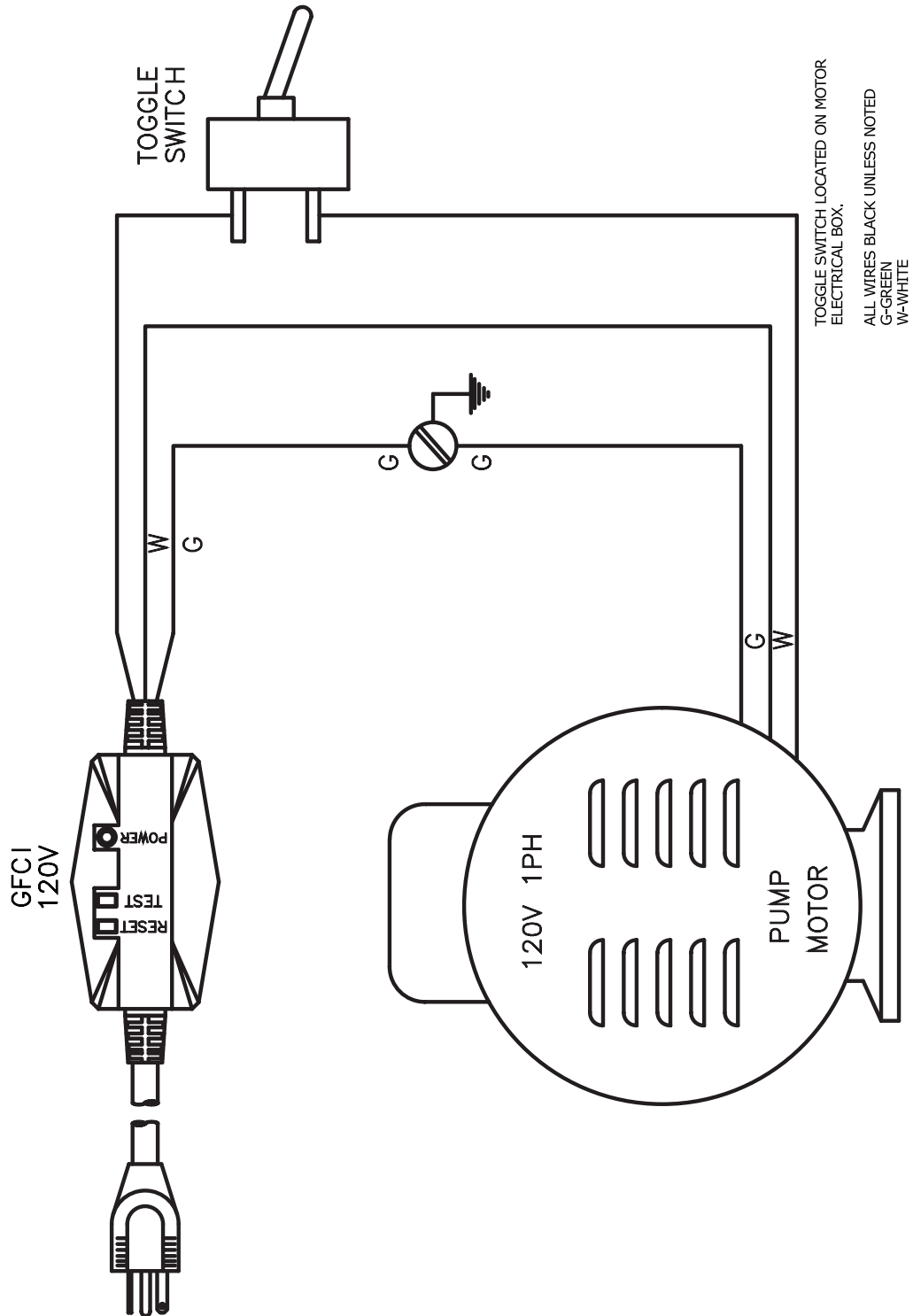

TROUBLESHOOTING

PROBLEM	POSSIBLE CAUSE	SOLUTION
PUMP RUNNING NORMALLY BUT PRESSURE LOW ON INSTALLATION	Pump sucking air	Check water supply and possibility of air seepage.
	Check valves sticking	Check and clean or replace if necessary.
	Unloader valve seat faulty	Check and replace if necessary.
	Nozzle incorrectly sized	Check and replace if necessary.
	Worn piston packing	Check and replace if necessary.
FLUCTUATING PRESSURE	Valves worn	Check and replace if necessary.
	Blockage in valve	Check and replace if necessary.
	Pump sucking air	Check water supply connections.
	Worn piston packing	Check and replace if necessary.
	Insufficient water	Check filter and hose for breakage.
PRESSURE LOW AFTER PERIOD OF NORMAL USE	Nozzle worn	Check and replace if necessary.
	Suction or delivery valves worn	Check and replace if necessary.
	Suction or delivery lines blocked	Check and clean if necessary.
	Unloader valve seat worn	Check and replace if necessary.
	Worn piston packing	Check and replace if necessary.
	Water temperature excessive	Reduce to below 160° F.
PUMP NOISY	Air in suction line	Check water supply and connections on suction line.
	Broken or weak suction or delivery valve spring	Check and replace if necessary.
	Foreign matter in valves	Check and clean if necessary.
	Worn bearings	Check and replace if necessary.
	Excessive temperature of water	Reduce to below 160° F.
PRESENCE OF WATER IN PUMP OIL	Oil seal worn	Check and replace if necessary.
	High humidity in air	Check and replace if necessary.
	Piston packing worn	Check and replace if necessary.
WATER DRIPPING FROM UNDER PUMP	Piston packing worn	Check and replace if necessary.
	O-ring plunger retainer worn	Check and replace if necessary.
WATER DRIPPING FROM PUMP PROTECTOR	Water supply pressure too high (over 90 PSI)	Lower water supply pressure using a regulator.
	Spray gun is in the off position for over 5 minutes	Turn machine off if not in use for over 1-2 minutes.
OIL DRIPPING	Oil seal worn	Check and replace if necessary.
EXCESSIVE VIBRATION IN HIGH PRESSURE HOSE	Irregular functioning of the pump valves	Check and replace if necessary.
MOTOR DOES NOT START WHEN SWITCHED ON	Plug not well connected or lack of power supply	Check plug, cable and switch.
WHEN SWITCHING ON THE MACHINE, MOTOR HUMS BUT DOES NOT RUN	Main voltage is insufficient, lower than the minimum required	Check to make sure main power supply is adequate.
	The pump is stuck or frozen	Check by turning the motor manually.
MOTOR STOPS	Tripped thermal overload due to overheating	Check that main voltage corresponds to the specifications. Wait a few minutes before turning on the machine again by resetting the GFCI cord.

PREVENTATIVE MAINTENANCE

PREVENTATIVE MAINTENANCE

This pressure washer was produced with the best available materials and quality craftsmanship. However, you as the owner have certain responsibilities for the correct care of the equipment. Attention to regular preventative maintenance procedures will assist in preserving the performance of your equipment. Contact your dealer for maintenance. Regular preventative maintenance will add many hours to the life of your pressure washer. Perform maintenance more often under severe conditions.

MAINTENANCE SCHEDULE		
Pump Oil (Non foaming) SAE 10W-40	Inspect	Daily inspect the oil level
	Change	After first 50 hours, then every 500 hours or annually
Replace High Pressure Nozzle		Every 6 months
Replace Quick Connects		Annually
Clean Water Screen/Filter		Weekly
Replace HP Hose		Annually if there is any sign of wear
Grease Motor		Every 10,000 hours

OIL CHANGE RECORD

Check pump oil and engine oil level before first use of your new pressure washer.

Date Oil Changed Month/Day/Year	Estimated Operating Hours Since Last Oil Change	Date Oil Changed Month/Day/Year	Estimated Operating Hours Since Last Oil Change

CONTENIDO

Información Importante de Seguridad.....	4-5
Instrucciones de funcionamiento para el modo de vaporización	6
Instrucciones de funcionamiento para el modo de alta presión.....	7
Vista detallada del ensamble.....	8
Lista de piezas de la vista detallada del ensamble.....	9-10
Vista detallada y lista de partes de la bomba	11
Vista detallada del filtro.....	12
Limpieza del filtro de entrada de agua.....	13
Vista detallada y lista de partes de bomba LF2030S	14-15
Vista detallada del descargador VRT3	16
Diagrama de cableado	17
Solución de problemas	18
Mantenimiento preventivo.....	19

Número de modelo _____

Número de serie _____

Fecha de compra _____

Los números de modelo y de serie se encuentran en una calcomanía adherida a la hidrolavadora. Debe registrar tanto el número de serie como la fecha de compra, y debe guardar esta información en un lugar seguro para referencia futura.

INTRODUCCIÓN E INFORMACIÓN IMPORTANTE DE SEGURIDAD

Gracias por comprar esta lavadora a presión.

Nos reservamos el derecho de realizar cambios en cualquier momento sin incurrir en ninguna obligación.

Responsabilidad del propietario y/o usuario:

El propietario y/o usuario deben comprender las instrucciones y advertencias de operación del fabricante antes de usar esta lavadora a presión. Se debe enfatizar y entender la información de advertencia. Si el operador no habla inglés con fluidez, el comprador y/o propietario deberá leer y discutir las instrucciones y advertencias del fabricante en el idioma nativo del operador, asegurándose de que el operador comprenda su contenido.

El propietario y/o usuario deben estudiar y conservar las instrucciones del fabricante para futura referencia.

El operador debe saber cómo detener la máquina rápidamente y comprender el funcionamiento de todos los controles. Nunca permita que alguien opere el motor sin las instrucciones apropiadas.

CONSERVE ESTAS INSTRUCCIONES

Este manual debe considerarse una parte permanente de la máquina y debe permanecer con ésta si la máquina se vuelve a vender.

Al ordenar partes, especifique el modelo y el número de serie. Utilice únicamente partes de reemplazo idénticas.

las a tierra (GFCI). Si el voltaje nominal es mayor de 250 voltios, o más de una fase, este producto solo se debe conectar a un receptáculo de alimentación eléctrica protegido por un GFCI.

PELIGRO: La conexión incorrecta del conductor de puesta a tierra del equipo puede dar como resultado el riesgo de electrocución. Si tiene alguna duda acerca de la puesta a tierra adecuada del tomacorriente, consulte con un electricista o técnico calificado. No modifique el enchufe provisto con el producto - si no encaja en el tomacorriente, solicite a un electricista calificado que le instale un tomacorriente adecuado. No use ningún tipo de adaptador con este producto



ADVERTENCIA: Mantenga la varilla, la manguera y el rocío de agua lejos del cableado eléctrico, ya que podrían producirse descargas eléctricas fatales.

5. Para proteger al operador contra descargas eléctricas, la máquina debe estar conectada a tierra. Es responsabilidad del

propietario conectar esta máquina a un receptáculo con puesta a tierra UL y clasificación de voltaje y amperaje adecuados. No rocíe agua sobre componentes eléctricos ni cerca de los mismos. No toque la máquina con las manos húmedas ni si está parado en una superficie con agua. Desconecte siempre la alimentación eléctrica antes de realizar tareas de mantenimiento.

INFORMACIÓN IMPORTANTE DE SEGURIDAD



ADVERTENCIA: Para reducir el riesgo de lesiones, lea cuidadosamente las instrucciones de operación antes de usar.

1. Lea el manual del propietario minuciosamente. El incumplimiento de las instrucciones podría ocasionar una falla de la máquina y provocar la muerte, lesiones corporales graves y/o daños materiales.
2. Sepa cómo detener la máquina y purgar la presión rápidamente. Familiarícese completamente con los controles.
3. Permanezca alerta — observe lo que está haciendo.
4. Todas las instalaciones deben cumplir con los códigos locales. Póngase en contacto con su electricista, plomero, empresa de servicios públicos o con el distribuidor de venta para obtener detalles específicos. Si el voltaje nominal de su máquina es 250 voltios o menos, se suministrará corriente monofásica con un interruptor de protección de fal-



ADVERTENCIA: Los líquidos inflamables pueden generar vapores que pueden encenderse y causar daños a la propiedad o lesiones graves.

ADVERTENCIA: Riesgo de explosión — Opere sólo donde se permitan llamas abiertas o soplete.

6. No permita que ácidos, fluidos cáusticos o abrasivos pasen a través de la bomba.
7. Nunca haga funcionar la bomba en seco ni deje la pistola rociadora cerrada por más de 1-2 minutos.
8. Mantenga el área de operación libre de personas.



ADVERTENCIA: El rociado a alta presión puede hacer que las partículas de pintura u otras partículas se transporten por aire y vuelen a altas velocidades. Para evitar lesiones personales, se deben usar dispositivos de seguridad para los ojos, manos y pies.

INTRODUCCIÓN E INFORMACIÓN IMPORTANTE DE SEGURIDAD

9. Se debe usar protección para los ojos, las manos y los pies al usar este equipo.



ADVERTENCIA: Sujete la varilla de limpieza firmemente con ambas manos antes de comenzar. De lo contrario, podría sufrir lesiones a partir de un latigazo de la varilla.



ADVERTENCIA: La alta presión desarrollada por estas máquinas causará lesiones personales o daños al equipo. Manténgase alejado de la boquilla. Tenga cuidado al operar. No dirija el flujo de descarga a las personas, ya que se producirán lesiones graves o la muerte.

10. Para reducir el riesgo de lesiones, es necesaria una estrecha supervisión cuando se utiliza una máquina cerca de niños. No permita que los niños operen la lavadora a presión. **Esta máquina debe ser atendida durante la operación.**

11. Nunca realice ajustes en la máquina mientras esté en funcionamiento.

12. Asegúrese que todos los accesorios del acoplador rápido estén asegurados antes de usar la lavadora a presión.



ADVERTENCIA: Proteja la máquina contra congelamiento.

13. Para mantener la máquina en las mejores condiciones de funcionamiento, es importante que proteja la máquina contra congelamiento. Si no protege la máquina contra congelamiento podría ocasionar una

falla de la máquina y causar la muerte, lesiones corporales graves y/o daños a la propiedad. Siga las instrucciones de almacenamiento especificadas en este manual.

14. El agua de entrada debe ser agua limpia y no debe tener una temperatura superior a 90°F (32°C).

15. El fabricante no será responsable de los cambios realizados en nuestras máquinas estándar o de los componentes que no se compren a nosotros.

16. El mejor seguro contra un accidente es la precaución y el conocimiento de la máquina.



ADVERTENCIA: Tenga mucho cuidado al usar una escalera, andamios o cualquier otra ubicación relativamente inestable. El área de limpieza debe tener pendientes y drenaje adecuados para reducir la posibilidad de una caída debido a las superficies resbaladizas.

17. No sobrepase ni se pare sobre un soporte inestable. Mantenga una buena posición para los pies y equilibrio en todo momento.

18. No opere esta máquina cuando esté fatigado o bajo la influencia del alcohol, medicamentos recetados o drogas.



ADVERTENCIA: No rocíe la máquina ni a personas, animales o piezas eléctricas.



Siga las instrucciones de mantenimiento especificadas en el manual.

INSTRUCCIONES DE FUNCIONAMIENTO PARA EL MODO DE VAPORIZACIÓN

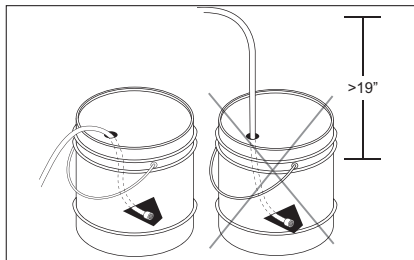

PASO 1: Conecte la manguera de ½" a un balde con desinfectante (Es recomendable que la toma de agua esté al nivel del suelo).

Nosotros recomendamos usar Vital Oxide.

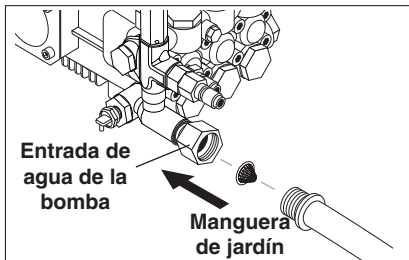

PASO 2: Conecte la manguera de ½" a la entrada de agua de la bomba.

PRECAUCIÓN: No haga funcionar la bomba sin agua o se producirán daños en la bomba.

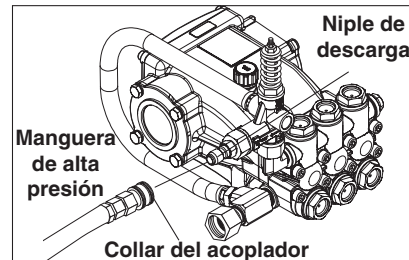

PASO 3: Conecte la manguera de alta presión de ¼" al niple de descarga. Empuje el collar del acoplador hacia adelante hasta que esté seguro.

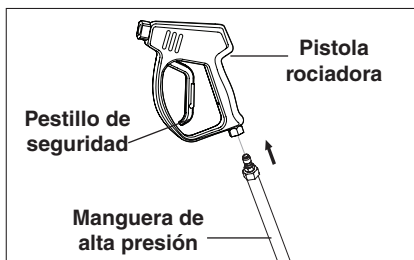

PASO 4: Conecte la manguera de alta presión a la pistola rociadora.

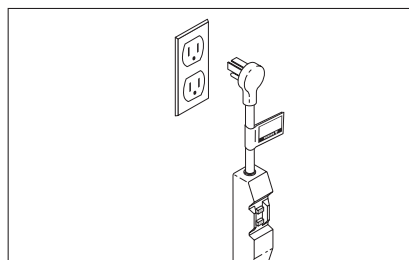

PASO 5: Conecte a una fuente de alimentación adecuada. Presione el botón de reinicio en el interruptor (GFCI).

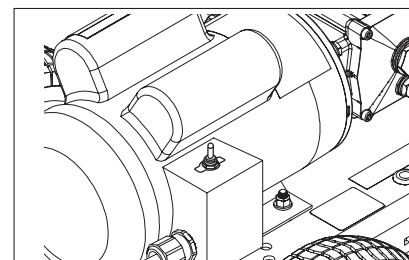

PASO 6: Ponga la máquina en funcionamiento.

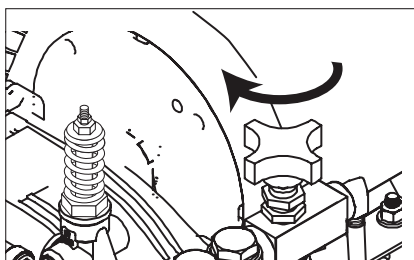

PASO 7: Cierre la válvula para purgar la manguera.

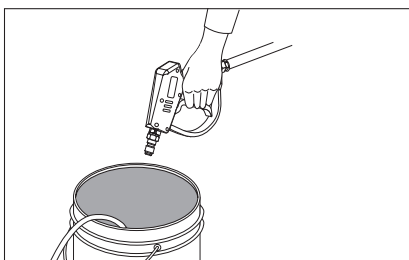

PASO 8: Purgue el aire atrapado en la manguera (Se recomienda hacer esto sobre el balde desinfectante).

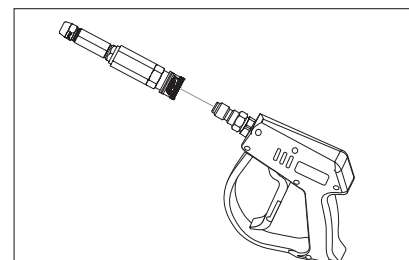

PASO 9: Coloque la boquilla de vaporización (mist) en la pistola rociadora.

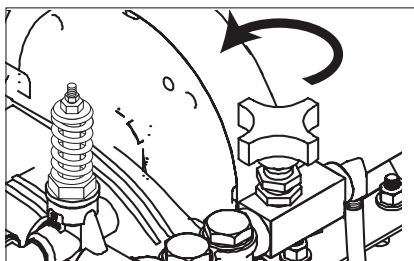

PASO 10: Abra la válvula para usar en modo de vaporización.

PRECAUCIÓN: Si la válvula permanece cerrada en el modo de vaporización, la boquilla puede dañarse.

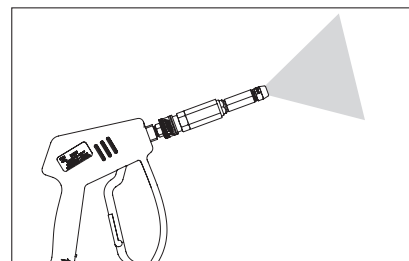

PASO 11: Listo para su uso, bruma (mist) Vital Oxide desinfectante.

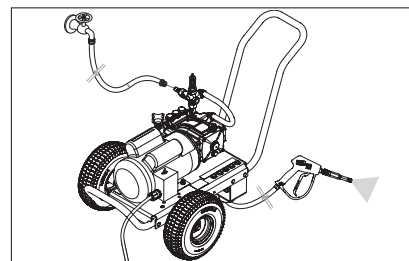

IMPORTANTE: Después de terminar el trabajo, elimine todos los restos químicos de la unidad. Llene el tanque con agua fresca y lave todo el sistema.

INSTRUCCIONES DE FUNCIONAMIENTO PARA EL MODO DE ALTA PRESIÓN

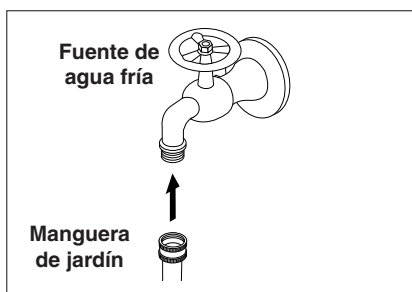

PASO 1: Conecte la manguera de ½" a la entrada de agua fría.

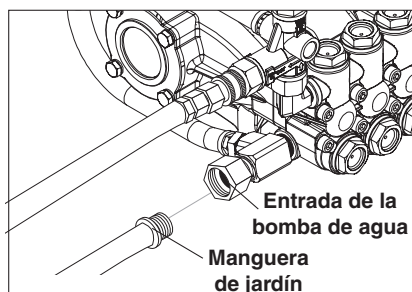

PASO 2: Revise los filtros de entrada, retire los residuos y luego conecte la manguera de jardín a la entrada de agua de la bomba.

PRECAUCIÓN: No opere la bomba sin agua o resultará en daños a la misma.

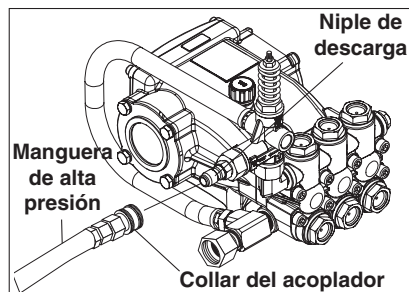

PASO 3: Conecte la manguera de alta presión de ¼" al niple de descarga. Empuje el collar del acoplador hacia adelante hasta que esté seguro.

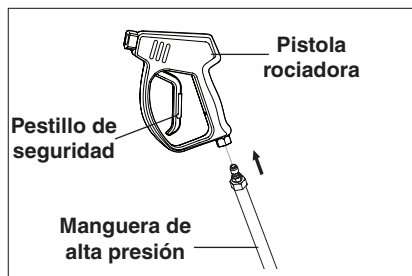

PASO 4: Conecte la manguera de alta presión a la pistola rociadora.

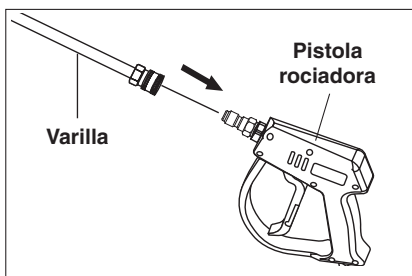

PASO 5: Conecte la varilla a la pistola rociadora.

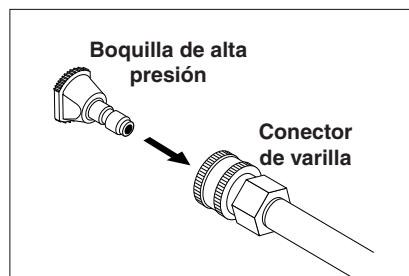

PASO 6: Jale el collar cargado por resorte del acoplador de varilla hacia atrás para insertar la boquilla de presión de su elección.

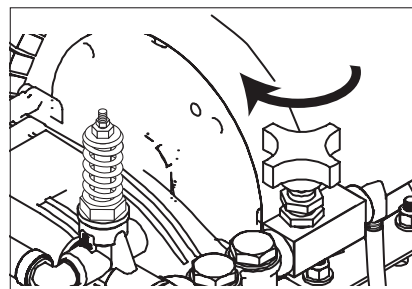

PASO 7: Cierre la válvula para purgar la manguera.

PRECAUCIÓN: Si la válvula está abierta, la presión no alcanzará el nivel máximo (rate).

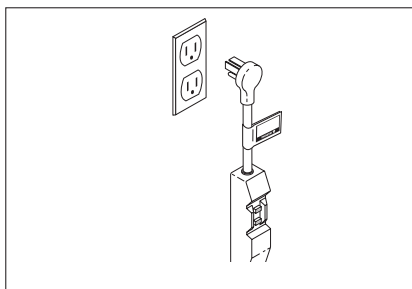

PASO 8: Conecte a una fuente de alimentación adecuada. Presione el botón de reinicio en el interruptor (GFCI).

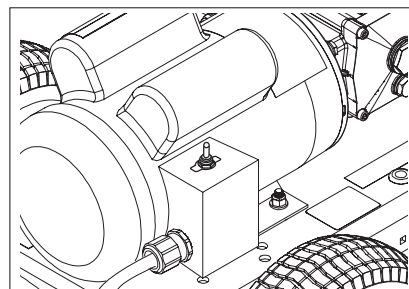

PASO 9: Ponga la máquina en funcionamiento.

VISTA DETALLADA DEL ENSAMBLE

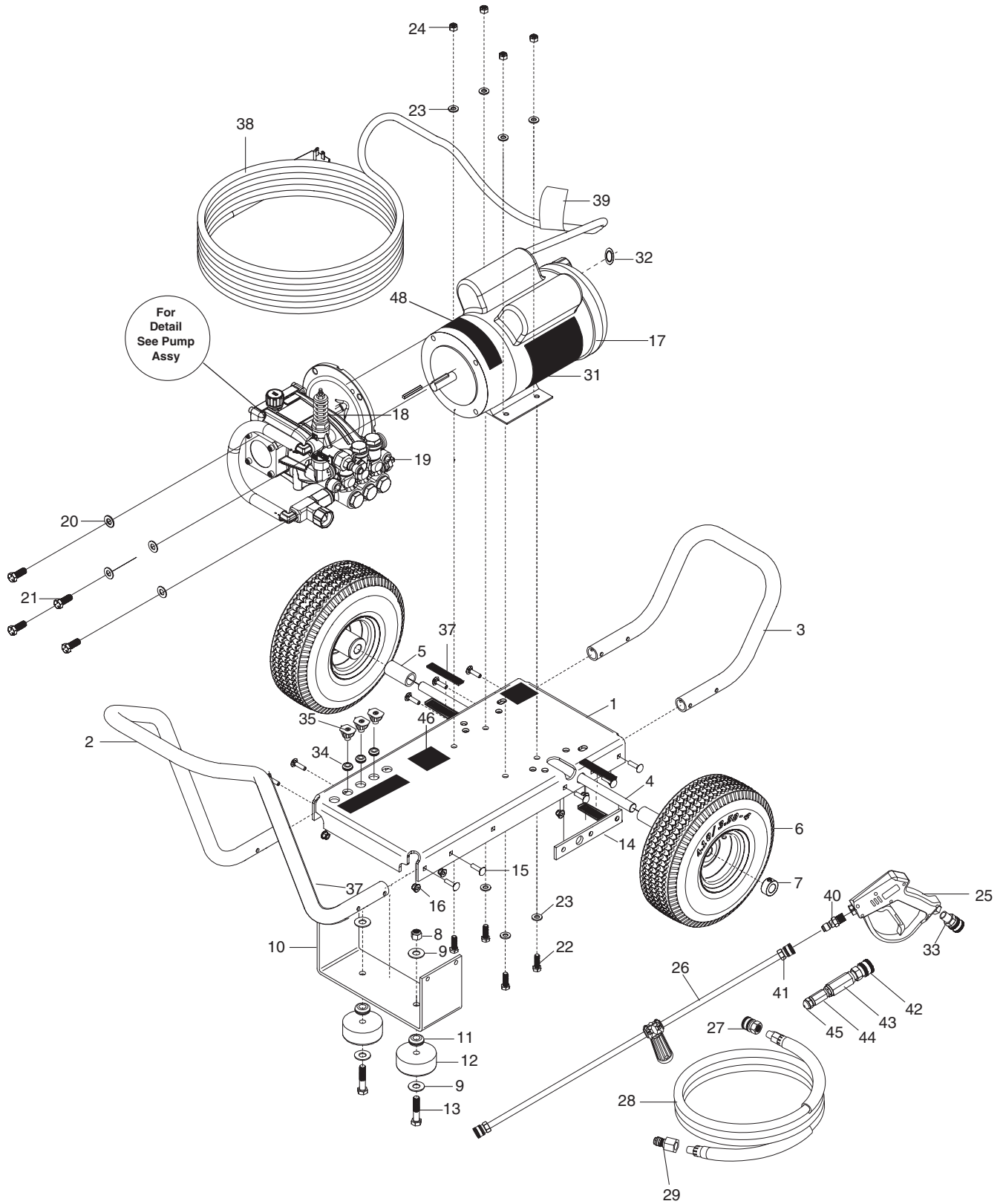

LISTA DE PARTES DEL ENSAMBLE

PZA.	NO. PARTE	DESCRIPCIÓN	CANT.
1	8.924-115.0	Al Base Direct Drive	1
2	8.924-394.0	Al Handle	1
3	8.924-393.0	Al Bumper	1
4	9.803-097.0	Axle, 5/8 X 20.125 Long	1
5	8.924-179.0	AL Spacer Tube DD Frame	2
6	8.756-365.0	QH Wheel Assy 10", Gray STL RIM, Flat	1
7	9.802-782.0	Collar, 5/8" Bore Shaft 3010	2
8	9.197-003.0	3/8-16 NE Nylon Insert L/N ZC 5UM White	2
9	9.802-817.0	Washer, 3/8" x 1"	4
10	8.924-116.0	Foot AL DD Frame CW	1
11	9.802-064.0	Grommet, Rubber, Nozzle Holder	2
12	9.802-066.0	Pad Soft Rubber	2
13	9.196-041.0	Hex Head Bolt 3/8-16 X 1-3/4	2
14	8.924-074.0	Camaro Silver Axle Holder DD CW	1
15	9.802-706.0	Bolt, 1/4"-20 x 1-3/4" Carriage Zinc	8
16	9.197-010.0	1/4-20" Nylon Insert Lock Nut With Flange	10
17	9.804-516.0	Motor, 1.5HP 1PH, 115V 1725RPM, TEFC	1
18	8.750-299.0	Unloader, VRT3, 8 GPM @4500 PSI	1
19	8.754-761.0	Pump, Leuco LF2030S, 2.1@3000, 1725RPM	1
20	9.198-004.0	3/8", USS F/W Zinc	4
21	9.802-720.0	Bolt, 3/8" x 1", NC HH	4
22	9.802-710.0	Screw 5/16" x 1" NC	4
23	8.718-980.0	Washer, 5/16" Flat, SAE	8
24	9.802-776.0	Nut, 5/16-18, ESNA	4
25	8.750-247.0	Trigger Gun Model m407	1
26	8.783-039.0	Wand 30" Zinc Plated, Handle & Coupler	1
27	9.802-166.0	Coupler, 3/8" Socket, Female, Brass	2
28	8.925-393.0	Hose 1/4"x75' 4000 PSI SWxSW CPL S120	1
29	9.802-170.0	Coupler, 3/8" Plug, Female, Steel Zinc	1
30	8.900-305.0	Label, Landa, Home Depot, ZE Warning	1
31	9.800-037.0	Label, French Inst./Warn	1
32	9.803-834.0	Washer, Reducing 3/4" x 1/2"	1
33	9.802-169.0	Coupler, 3/8"Socket, Male, Brass	1
34	8.755-187.0	Grommet, Rubber, Nozzle Holder Base 3/16	5
35	8.712-338.0	Nozzle, SAQCMEG 1503.5, Yellow	1
	8.712-339.0	Nozzle, SAQCMEG, 2503.5, Green	1
	8.712-340.0	Nozzle, SAQCMEG 4003.5, White	1
36	9.800-016.0	Label, Disconnect Power Supply	1
37	8.755-210.0	Four Nozzle Label, Black	1
38	9.802-432.0	GFCI, 120V 15A, W/ 36' 12-3 CORD	1
39	8.932-969.0	Label, Warning, Service Cord	1
40	8.707-139.0	Coupler, 1/4"Plug, Male, Steel/Zinc	1
41	9.802-164.0	Coupler, 1/4"Socket, Female, Brass	1
42	8.756-030.0	Coupler, 1/4 Socket, Male, Brass	1
43	8.709-175.0	Filter,High Pressure 1/4"Npt-Fx1/4"Np	1
44	8.758-918.0	Adapter 9/16 X 1/4	1
45	8.756-697.0	Fuel Nozzle, 2.50 X 80 BZ	1
46	9.800-049.0	Label, Manufacturer's cleaning solution	1

VISTA DETALLADA DE BOMBA

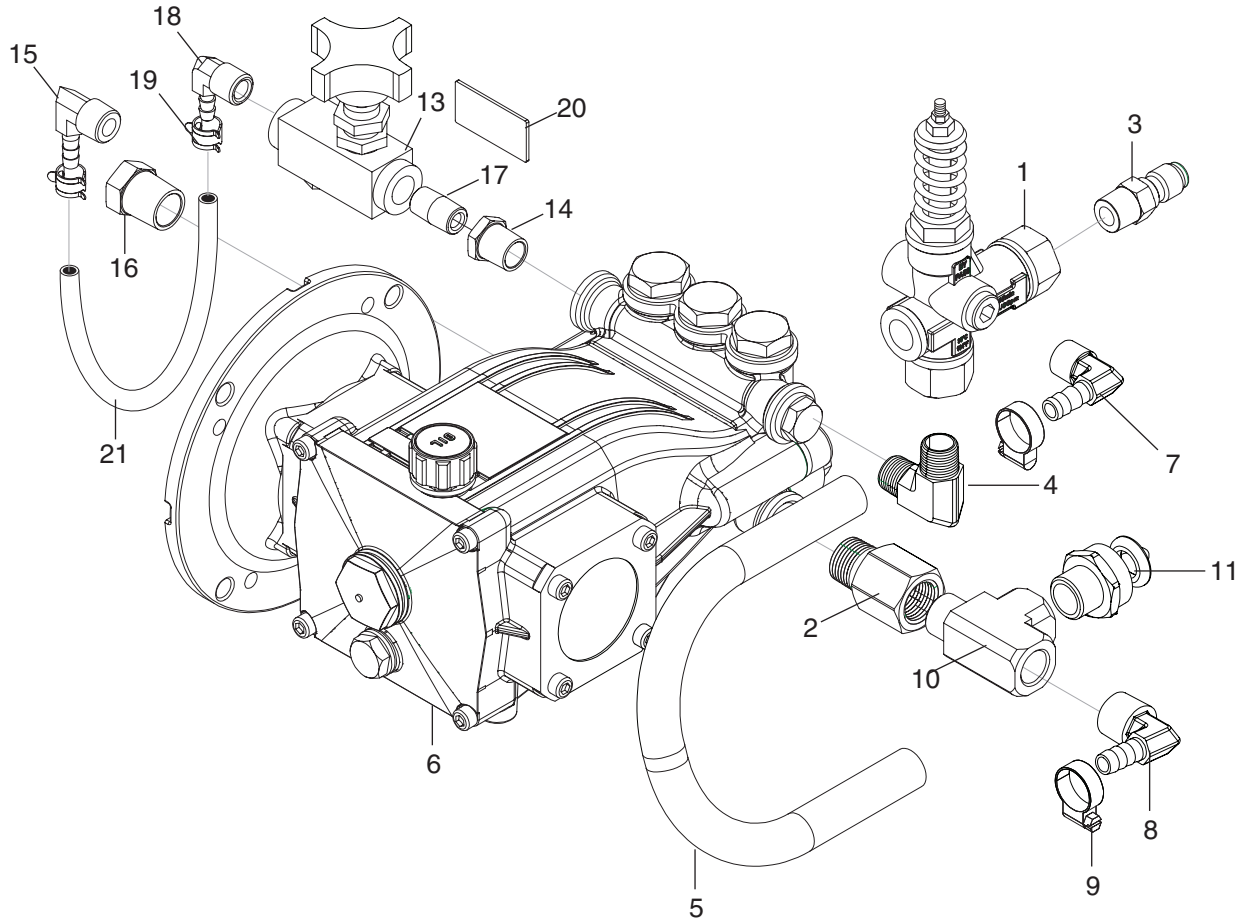

LISTA DE PARTES DE VISTA DETALLADA DE LA BOMBA

PZA.	NO. PARTE	DESCRIPCIÓN	CANT.	PZA.	NO. PARTE	DESCRIPCIÓN	CANT.
1	8.750-299.0	Unloader, Vrt3, 8 Gpm @4500 Psi	1	13	8.707-317.0	Valve, Flow Control	1
2	8.757-193.0	Adapter, 1/2" F-Nptf X 1/2" M-Nptf, Brass	1	14	8.706-297.0	Bushing, 3/8" X 1/4" Steel Yellow Chrom	1
3	8.707-152.0	Nipple, 3/8", Male, Ssteel	1	15	8.706-965.0	Hose Barb, 1/4" Barb X 3/8" Npt-M, 90	1
4	8.757-511.0	Elbow, 3/8", Steel	1	16	8.706-294.0	Bushing, 1/2" X 3/8", Steel P/N-5406-	1
5	8.711-785.0	Hose, 3/8 Push On	1	17	8.757-337.0	Nipple, 1/4" Close Sch 80 Steel, W/SInt	1
6	8.758-069.0	Pump LEUCO LFP2030S, 2.1 @3000, 1725RPM	1	18	8.757-205.0	Hose Barb, 1/4" Barb X 1/4" M-Nptf, 90	1
7	8.705-119.0	Hose Barb, Elbow, 3/8"Barbx3/8"Mpt/90Deg	1	19	6.390-126.0	Clamp Hose	2
8	8.758-199.0	Hose Barb Elbow 3/8"X1/2" 90 Deg W/SInt	1	20	8.758-919.0	Label Valve Label.	1
9	8.623-315.0	Clamp, 3/8 Hose (D-Slot)	2	21	9.802-254.0	Hose, 1/4 Push-On	5"
10	8.757-257.0	Tee, Street 1/2"	1				
11	8.757-203.0	Swivel, 1/2" M-Nptf X 3/4" Ghf	1				
12	9.804-016.0	Filter Screen Washer, Garden Hose/30Mesh	1				

VISTA DETALLADA DEL FILTRO

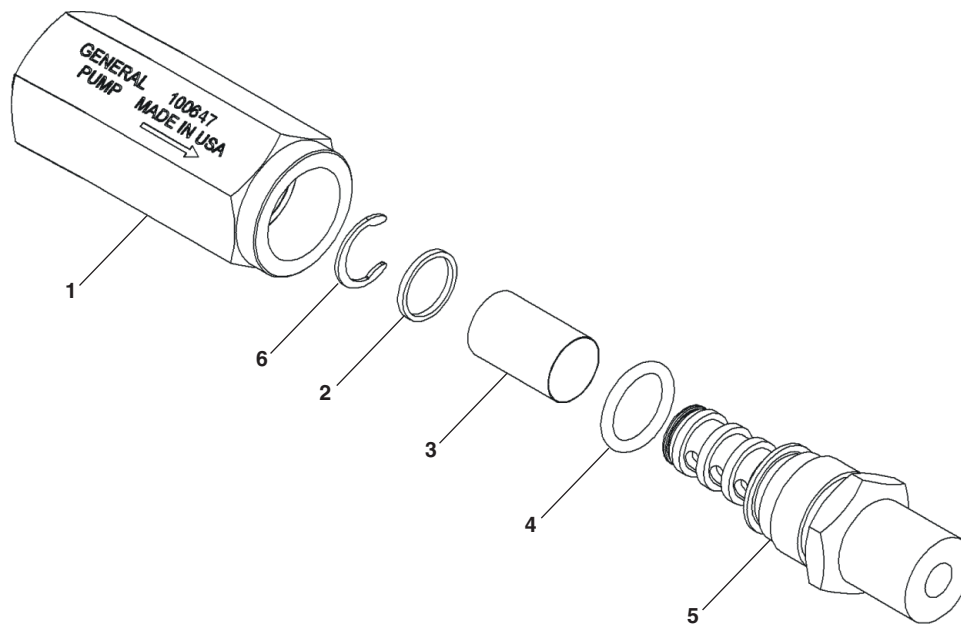

LISTA DE PARTES DEL FILTRO

PZA	DESCRIPCIÓN	CANT.
1	Housing, Nozzle Filter, 1/4 NPT-F	1
2	Retainer, Filter	1
3	Screen, 100 Mesh, T304SS	1
4	O-Ring, 70 Duro, Buna-N, .426 ID x .070 CS	1
5	Outlet Fitting, Nozzle Filter, 1/4 NTP-M	1
6	Retainer, External, SS	1

LIMPIEZA DEL FILTRO DE ENTRADA DE AGUA

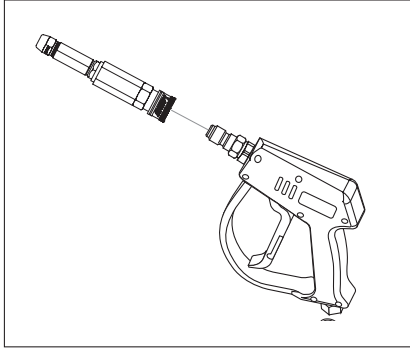

PASO 1: Desconecte la boquilla de pulverización de la máquina.

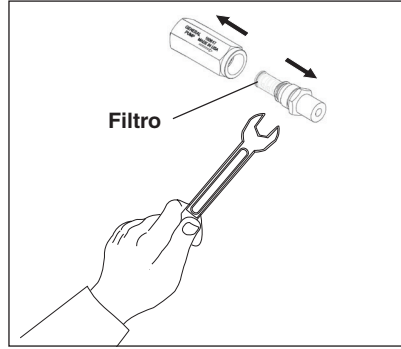

PASO 2: Saque el filtro de entrada de agua. Utiliza las herramientas necesarias.

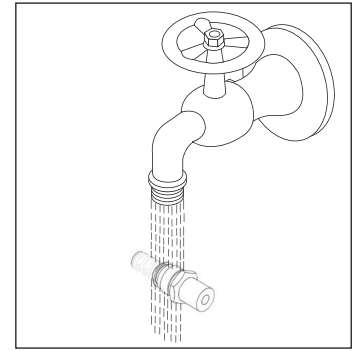

PASO 3: Enjuague el filtro de entrada de agua en agua tibia.

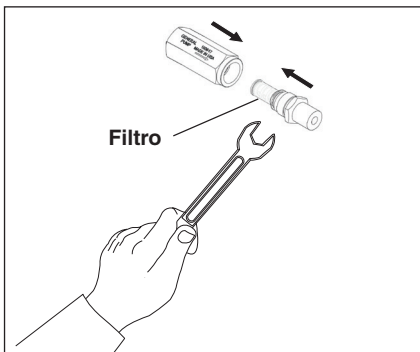

PASO 4: Montar el filtro de entrada de agua. Utiliza las herramientas necesarias.

VISTA DETALLADA DE LA BOMBA LF 2030S

8.924-736.0 LF 2030S

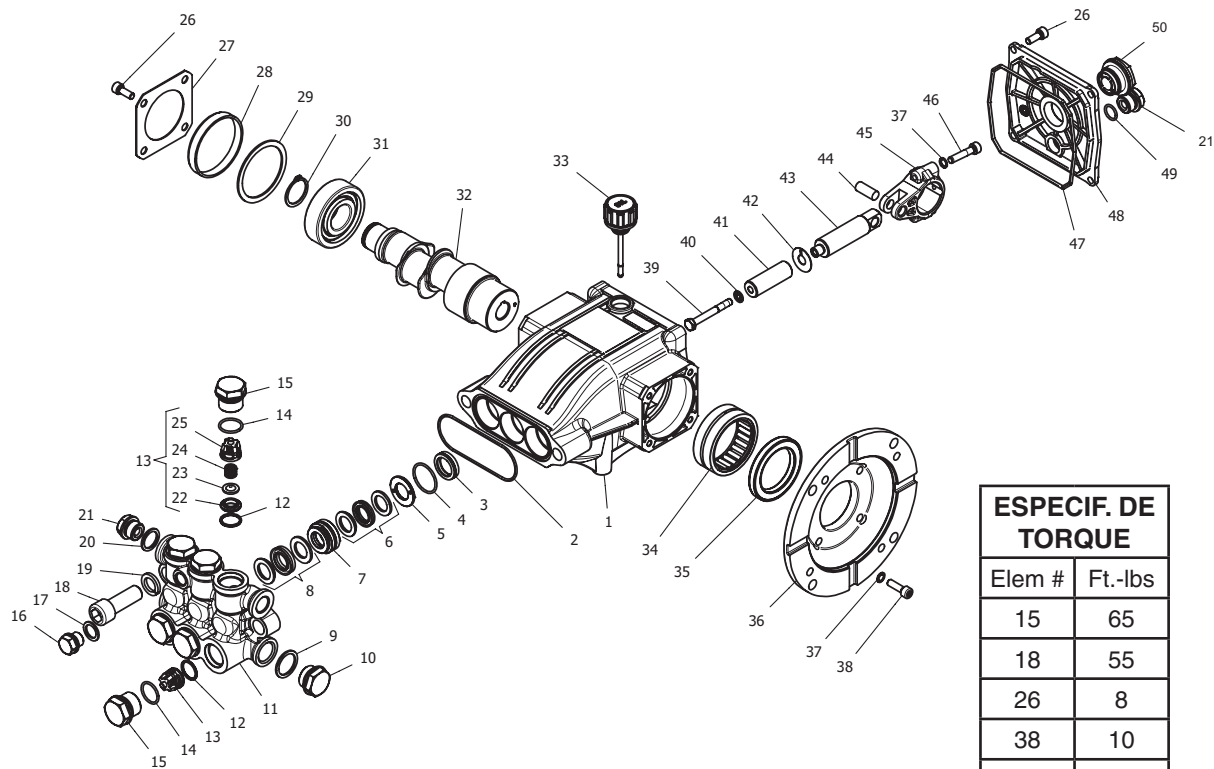

ESPECIF. DE TORQUE	
Elem #	Ft.-lbs
15	65
18	55
26	8
38	10
39	10
46	10

LISTA DE PARTES DE LA BOMBA LF 2030S

PZA. NO. PARTE	DESCRIPCIÓN	CANT.	PZA. NO. PARTE	DESCRIPCIÓN	CANT.
1	8.754-841.0 Crankcase	1	19	8.754-850.0 Washer, Lock	2
2	8.754-846.0 O-ring Ø1.78 X 72.75	1	20	9.803-198.0 Washer, Copper G3/8	1
3*	Ver Kits Abajo Plunger Oil Seal	3	21	8.707-262.0 Plug, Brass G3/8	2
4*	Ver Kits Abajo O-ring Ø1.78 X 26.7	3	22*	Ver Kits Abajo Valve Seat	6
5*	Ver Kits Abajo Washer, Pressure Ring	3	23*	Ver Kits Abajo Valve Plate	6
6*	Ver Kits Abajo U-Seal	3	24*	Ver Kits Abajo Valve Spring	6
7*	Ver Kits Abajo Pressure Ring	3	25*	Ver Kits Abajo Valve Cage	6
8*	Ver Kits Abajo U-Seal	3	26	9.802-939.0 Screw, M6 X 16	8
9	9.803-199.0 Washer, Copper G1/2	1	27	8.717-137.0 Bearing Cover	1
10	9.802-926.0 Plug, Brass G1/2	1	28	9.803-954.0 Bearing Seal	1
11	8.754-852.0 Manifold (16mm Modelos)	1	29	8.754-843.0 Seal Spacer, Crankshaft	1
	8.754-853.0 Manifold (14mm Modelos)	1	30	9.802-914.0 Snap Ring, 25 mm	1
12*	8.717-233.0 O-ring Ø1.78 X 15.6	6	31	9.803-955.0 Bearing, Ball	1
13*	See Kits Below Valve Assembly	6	32	8.754-836.0 Shaft, 5/8" Hollow	1
14*	9.803-948.0 O-ring Ø1.78 X 18.77	6	33	8.754-219.0 Oil Dipstick	1
15	9.803-949.0 Valve Plug	6	34	8.754-840.0 Bearing Needle	1
16	8.754-851.0 Plug, Brass G1/4 (16mm)	1	35	8.754-826.0 Seal, Crankshaft	1
17	8.754-845.0 Washer, Copper G1/4 (16mm Models)	1	36	8.754-844.0 Flange, Motor	1
18	8.754-854.0 Bolt, Manifold M14 X 40	2	37	9.803-210.0 Washer	10
			38	8.752-824.0 Screw, 6 mm	4

LISTA DE PARTES DE LA BOMBA LF 2030S

PZA.	PARTE NO.	DESCRIPCIÓN	CANT.
39*	8.754-855.0	Bolt, Plunger	3
40*	8.754-092.0	Spacer, Copper	3
41	8.754-848.0	Plunger, 16mm	3
42	9.803-962.0	Spacer, Copper	3
43	8.754-827.0	Plunger Rod	3
44	9.803-965.0	Connecting Rod Pin	3
45	9.803-966.0	Connecting Rod	3
46	8.933-020.0	Screw, Connecting Rod	6
47	8.754-847.0	O-ring Ø2.62 X 111.62	1
48	8.754-842.0	Cover, Crankcase	1
49	9.803-906.0	O-ring Ø1.78 X 14	1
50	9.803-202.0	Sight Glass, G3/4	1

NÚMERO DE EQUIPO DE REPARACIÓN	8.754-860.0	8.754-856.0	8.754-861.0	8.754-857.0	8.754-862.0	8.754-858.0	8.754-859.0	9.803-937.0
DESCRIPCIÓN DEL EQUIPO	Plunger Seals 14 mm**	Plunger Seals 16 mm**	Seal Packing 14 mm**	Seal Packing 16 mm**	Plunger 14 mm**	Plunger 16 mm**	Complete Valve	Plunger Oil Seals
NÚMEROS DE ARTÍCULO INCLUIDO	4, 6, 8	4, 6, 8	4, 5, 6, 7, 8	4, 5, 6, 7, 8	39, 40, 41, 42	39, 40, 41, 42	12, 13, 14	3

VISTA DETALLADA DEL DESCARGADOR VRT3

8.750-299.0, 8 GPM, 4500 PSI

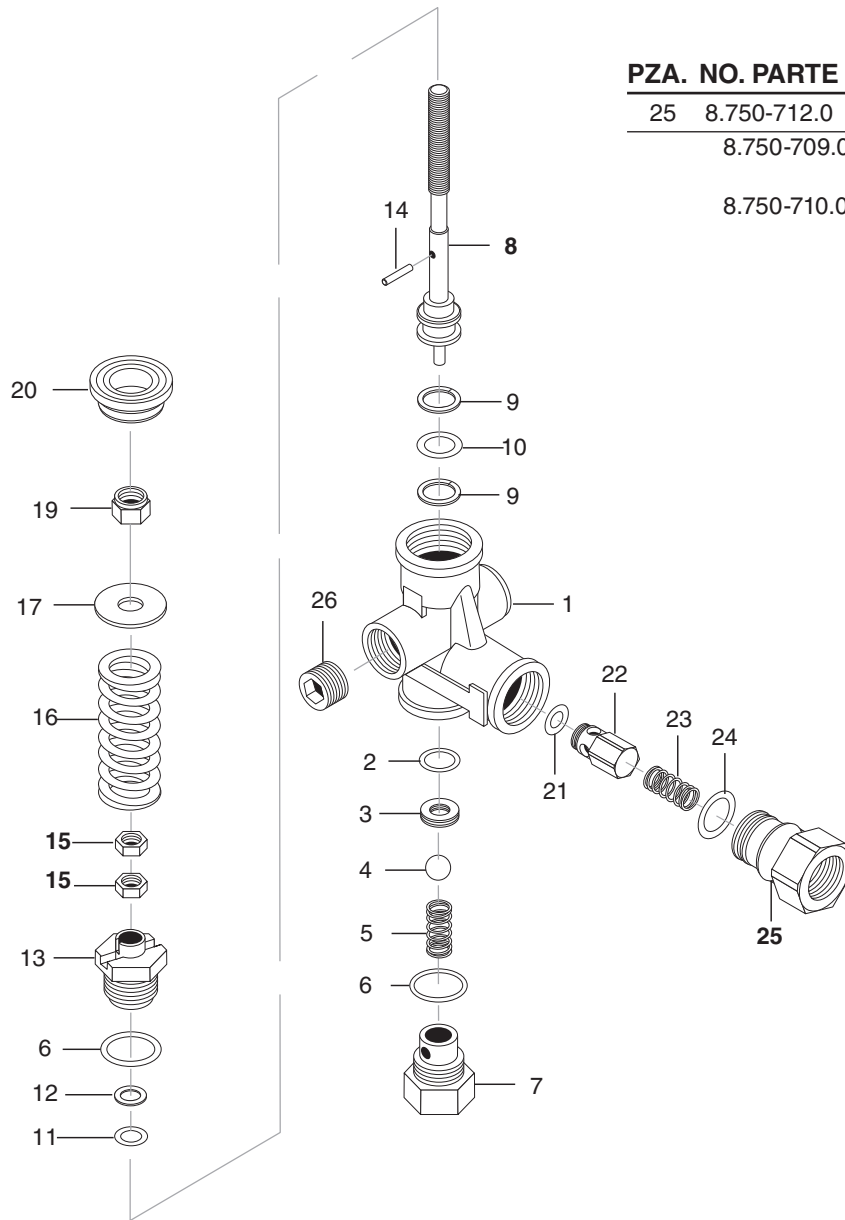

PZA.	NO. PARTE	DESCRIPCIÓN	CANT.
25	8.750-712.0	Outlet Fitting	1
	8.750-709.0	Repair Kit, VRT3, 2320/3630 PSI	
	8.750-710.0	Repair Kit, VRT3, 4500 PSI (Kit piezas: 1, 4, 8-12, 16, 21-22)	

Procedimientos de ajuste del descargador

1. Retirar contratuerca (Componente 19)
2. Aflojar las dos tuercas (Componente 15) y desplazar hacia la parte superior del eje (Componente 8) hasta que 4 o más hilos de la roca sean visibles bajo la tuerca.
3. Encender máquina. Presionar gatillo de la pistola rociadora. Incrementar la presión girando la en sentido de las manecillas del reloj hasta obtener la presión deseada.
4. Apretar la tuerca inferior (Componente 15) contra la tuerca superior (Componente 15). Atornillar contratuerca (Componente 19) al eje (Componente 8) hasta que las roscas corten el inserto de nylon de esta (Componente 19).

** Suelte el gatillo de la pistola rociadora, observar el manómetro durante el aumento de la presión ("pico"), este NO debe de exceder los 500 PSI por encima de la presión de operación. Si esta presión excede los el límite de 500 PSI, vuelva a ajustar las tuercas (Componente 15) desplazándolas hacia abajo del eje (Componente 8), una vez terminada esta operación, es necesario repetir el paso 4.

DIAGRAMA DE CABLEADO

1.106-160.0 HD 2.0/1000 Dual Mister

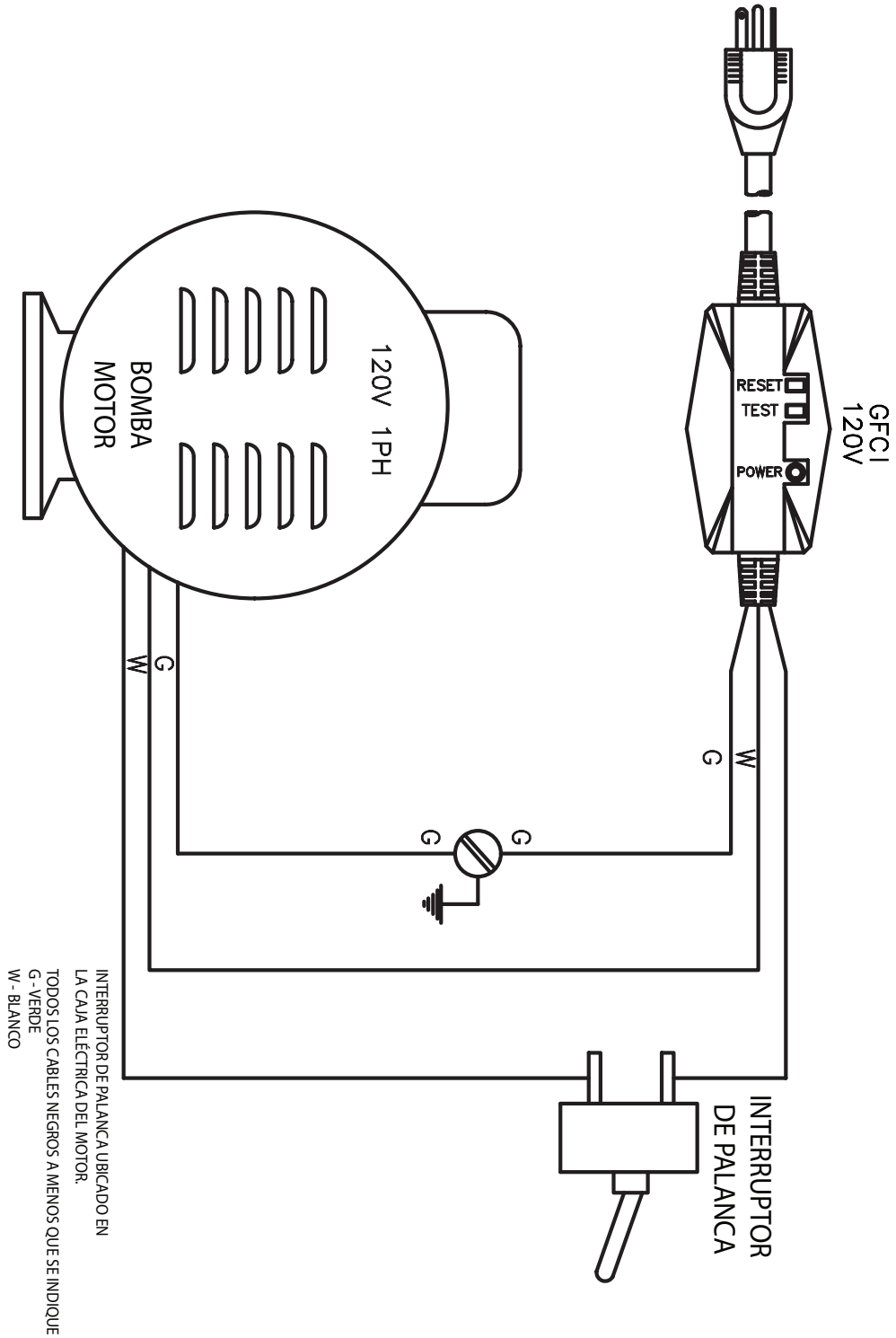

SOLUCIÓN DE PROBLEMAS

PROBLEMA	CAUSA POSIBLE	SOLUCIÓN
BOMBA FUNCIONANDO NORMALMENTE PEROPRESIÓN BAJA EN INSTALACIÓN	La bomba está aspirando aire	Compruebe el suministro de agua y la posibilidad de infiltración de aire.
	Válvulas adheridas	Revise y limpie o reemplace si es necesario.
	El asiento de la válvula del descargador está defectuoso	Revise y reemplace si es necesario.
	Boquilla de tamaño incorrecto	Revise y reemplace si es necesario.
	Empaque de pistón desgastado	Revise y reemplace si es necesario.
PRESIÓN FLUCTUANTE	Válvulas de bomba gastadas	Revise y reemplace si es necesario.
	Bloqueo en la válvula	Revise y reemplace si es necesario.
	La bomba succiona aire	Revise las conexiones de suministro de agua.
	Empaque de pistón desgastado	Revise y reemplace si es necesario.
	Suministro de agua insuficiente	Compruebe si el filtro y la manguera están rotos.
PRESIÓN BAJA DESPUÉS DEL PERÍODO DE USO NORMAL	Boquilla gastada	Revise y reemplace si es necesario.
	Válvulas de succión o suministro desgastadas	Revise y reemplace si es necesario.
	Líneas de succión o suministro bloqueadas	Revise y limpie si es necesario.
	La válvula del descargador está desgastada	Revise y reemplace si es necesario.
	Empaque de pistón desgastado	Revise y reemplace si es necesario.
	Temperatura del agua excesiva	Reducir a menos de 160° F (71.11° C)
LA BOMBA ES RUIDOSA	Aire en la línea de succión	Verifique el suministro de agua y las conexiones en la línea de succión.
	Resorte de la válvula de succión o suministro roto o débil	Revise y reemplace si es necesario.
	Materia extraña en válvula	Revise y limpie si es necesario.
	Cojinetes desgastados	Revise y reemplace si es necesario.
	Temperatura del agua excesiva	Reducir a menos de 160° F (71.11° C)
PRESENCIA DE AGUA EN ACEITE DE BOMBA	Sello de aceite desgastado	Revise y reemplace si es necesario.
	Alta humedad en el aire	Revise y reemplace si es necesario.
	Empaque de pistón desgastado	Revise y reemplace si es necesario.
GOTEO DE AGUA EN LA PARTE INFERIOR DE LA BOMBA	Empaque de pistón desgastado	Revise y reemplace si es necesario.
	Anillo O del retén del émbolo desgastado	Revise y reemplace si es necesario.
GOTEO DE AGUA DESDE EL PROTECTOR DE BOMBA	Presión de suministro de agua demasiado alta (más de 90 PSI)	Reduzca la presión del suministro de agua con un regulador.
	La pistola rociadora está en la posición de apagado, por más de 5 minutos.	Apague la máquina si no la usa por más de 1-2 minutos.
GOTEO DE ACEITE	Sello de aceite desgastado	Revise y reemplace si es necesario.
VIBRACIÓN EXCESIVA EN MANGUERA DE ALTA PRESIÓN	Funcionamiento irregular de las válvulas de la bomba	Revise y reemplace si es necesario.
EL MOTOR NO ARRANCA CUANDO SE ENCIENDE	Enchufe no bien conectado o falta de corriente eléctrica.	Compruebe el enchufe, el cable y el interruptor.
AL ENCENDER LA MÁQUINA, EL MOTOR HUME PERO NO FUNCIONA	El voltaje principal es insuficiente, más bajo que el mínimo requerido	Compruebe que la fuente de alimentación principal sea la adecuada.
	La bomba está atascada o congelada	Verifique girando el motor manualmente.
MOTOR DETENIDO	Sobrecarga térmica disparada debido a sobrecalentamiento	Verifique que la tensión principal corresponda con las especificaciones. Espere unos minutos antes de volver a encender la máquina reiniciando el cable GFCI.

MANTENIMIENTO PREVENTIVO

MANTENIMIENTO PREVENTIVO

Esta lavadora a presión fue producida con los mejores materiales disponibles y mano de obra de calidad. Sin embargo, usted como propietario tiene ciertas responsabilidades para el cuidado correcto del equipo. La atención a los procedimientos regulares de mantenimiento preventivo ayudará a preservar el desempeño de su equipo. Póngase en contacto con su distribuidor para el mantenimiento. El mantenimiento preventivo regular agregará muchas horas a la vida útil de su lavadora a presión. Realice el mantenimiento más a menudo en condiciones severas.

PROGRAMA DE MANTENIMIENTO		
Aceite de bomba (Anti-espuma) SAE 10W-40	Revisar	Nivel de aceite Diario o cada uso
	Cambiar	Después de las primeras 50 horas, y después cada 500 horas o anualmente.
Reemplace la boquilla de alta presión		Cada 6 meses
Reemplace las conexiones rápidas		Anualmente
Limpie la pantalla y el filtro de agua		Semanalmente
Reemplazar manguera HP		Anualmente (si hay cualquier señal de desgaste)
Grease Motor		Every 10,000 hours

REGISTRO DE CAMBIO DE ACEITE

Verifique el aceite de la bomba y el nivel del aceite del motor antes de usar por primera vez su nueva lavadora a presión.

Fecha de cambio de aceite de la bomba Mes/Día/Año	Horas de funcionamiento estimadas desde el último cambio de aceite

Fecha de cambio de aceite de la bomba Mes/Día/Año	Horas de funcionamiento estimadas desde el último cambio de aceite



THANK YOU!
MERCI! ¡GRACIAS! DANKE!



Register your product and benefit from many advantages.

Enregistrez votre produit et bénéficiez de nombreux avantages.

Registre su producto y aproveche de muchas ventajas.

Registrieren Sie Ihr Prudukt und Sie von vielen Vorteilen.

www.kaercher.com/welcome



Rate your product and tell us your opinion.

Évaluez votre produit et donnez-nous votre opinion.

Reseña su producto y díganos su opinión.

Bewerten Sie Ihr Produkt und sagen Sie uns Ihre Meinung.

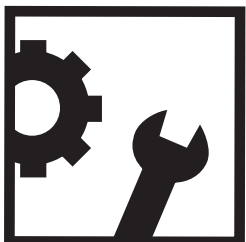

www.kaercher.com/dealersearch

Kärcher North America
6398 N Kärcher Way
Aurora, CO 80019
Phone: +1 800 444-7654

