

KÄRCHER

makes a difference

Commodore Duo

English

02

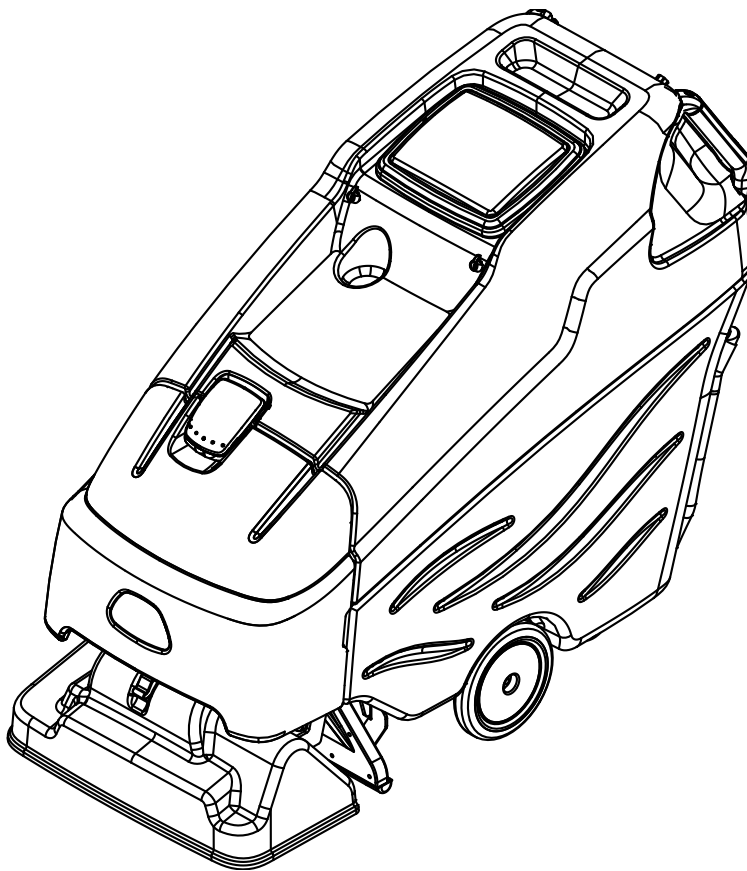

**Register
your product**

www.kaercher.com/welcome



86447840-A 12/01/20

Machine Data Label

Model: _____

Date of Purchase: _____

Serial Number: _____

Dealer: _____

Address: _____

Phone Number: _____

Sales Representative: _____

Overview

The Commodore Duo is a battery powered carpet extractor intended for commercial use. The Commodore Duo applies a cleaning solution onto a carpeted floor, sweeps and scrubs the carpet with two counter-rotating brushes and then vacuums the soiled water back into the recovery tank.

MODELS:

1.008-002.0

1.008-003.0

1.008-004.0

1.008-006.0

1.008-658.0

Warranty Registration

Thank you for purchasing a Kärcher North America product. Warranty registration is quick and easy. Your registration will allow us to serve you better over the lifetime of the product.

To register your product go to :
<http://warranty.karcherna.com>

For customer assistance:
1-800-444-7654

KÄRCHER

Machine Data Label	2
Overview.....	2
Table of Contents	3
How To Use This Manual	4

Safety

Safety Labels.....	5
IMPORTANT SAFETY INSTRUCTIONS.....	6
Hazard Intensity Level.....	8

Operations

Technical Specifications	11
How This Machine Works.....	12
Components	13
Drive Controls.....	14
Scrub Controls.....	16
Machine Operation	18
Pre-Run Machine Inspection	18
Starting Machine.....	18
Emergency Stop Procedures.....	18
Filling Solution Tank	18
Normal Scrubbing.....	19
To Begin Scrubbing	19
To Stop Scrubbing	19
Emptying And Cleaning Solution Tank.....	20
Emptying And Cleaning Recovery Tank	20

Maintenance

Service Schedule.....	22
Batteries	23
Batteries (Wet Cell Only).....	24
Charging Batteries.....	25
Changing Batteries	26
Scrub Deck.....	27
Scrub Brushes.....	28
Brush Motor Carbon Brush Replacement.....	29
Actuator Scrub Deck Removal/Replacement	30
Scrub Deck Actuator Adjustment.....	30
Circuit Protection	31
Solution Strainer & Pump	32
Drive Assembly.....	34
Vacuum.....	36
Vacuum Motor Carbon Brushes	38
Transporting Machine.....	38
Machine Troubleshooting	39
Suggested Spare Parts	40

How To Use This Manual

This manual contains the following sections:

- How to Use This Manual
- Safety
- Operations
- Maintenance
- Suggested Spare Parts List

The HOW TO USE THIS MANUAL section will tell you how to find important information for ordering correct repair parts.

Parts may be ordered from authorized dealers. When placing an order for parts, the machine model and machine serial number are important. Refer to the MACHINE DATA box which is filled out during the installation of your machine. The MACHINE DATA box is located on the inside of the front cover of this manual.

Model: _____
Date of Purchase: _____
Serial Number: _____
Dealer: _____
Address: _____
Phone Number: _____
Sales Representative: _____

The model and serial number of your machine are located on the back of the machine.

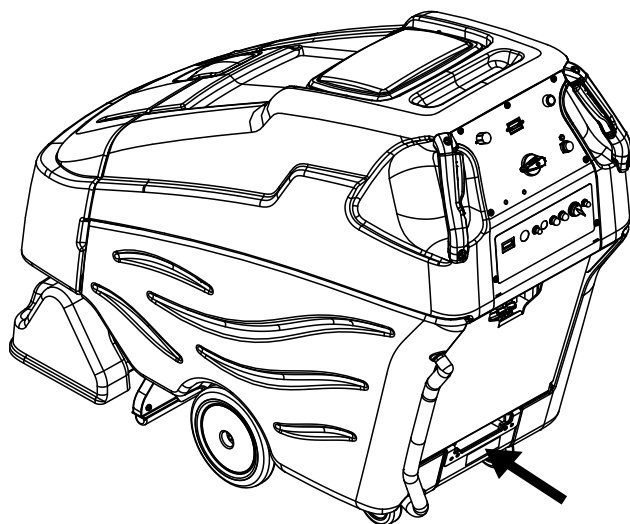

The SAFETY section contains important information regarding hazardous or unsafe practices of the machine. Levels of hazards are identified that could result in product damage, personal injury, or severe injury resulting in death.

The OPERATIONS section is to familiarize the operator with the operation and function of the machine.

The MAINTENANCE section contains preventive maintenance to keep the machine and its components in good working condition. They are listed in this general order:

- Batteries
- Scrub Brushes
- Service Schedule
- Machine Troubleshooting

NOTE: The manual part number is located on the lower right corner of the front cover.

Safety Labels

These drawings indicate the location of safety labels on the machine. If at any time the labels become illegible, promptly replace them.

EMPLACEMENT DE L'ÉTIQUETTE DE SÉCURITÉ

REMARQUE : Ces dessins indiquent l'emplacement des étiquettes de sécurité sur la machine. Si, à tout moment, les étiquettes deviennent illisibles, contactez votre représentant autorisé pour un remplacement rapide.

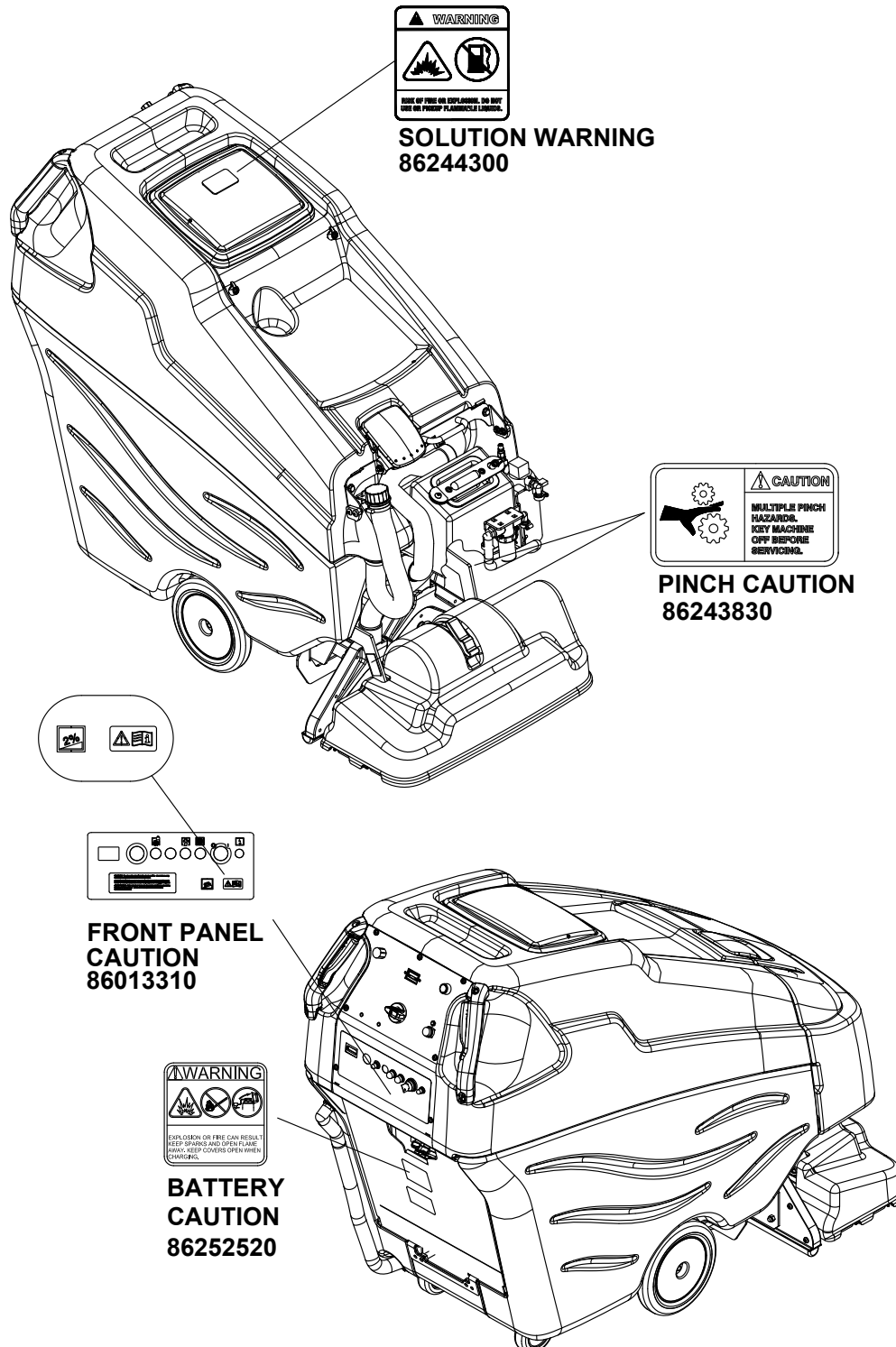

IMPORTANT SAFETY INSTRUCTIONS

When using this machine, basic precaution must always be followed, including the following:
READ ALL INSTRUCTIONS BEFORE USING THIS MACHINE.

⚠ WARNING: To reduce the risk of fire, electric shock, or injury:

- Use only indoors. Do not use outdoors or expose to rain.
- Use only as described in this manual. Use only manufacturer's recommended components and attachments.
- If the machine is not working properly, has been dropped, damaged, left outdoors, or dropped into water, return it to an authorized service center.
- Do not operate the machine with any openings blocked. Keep openings free of debris that may reduce airflow.
- This machine is not suitable for picking up hazardous dust.
- Do not operate this machine near flammable fluids, dust or vapors.
- Maintenance and repairs must be done by qualified personnel.
- If foam or liquid comes out of machine, switch off immediately.
- Disconnect battery before cleaning or servicing.
- Before the machine is discarded, the batteries must be removed and properly disposed of.
- Make sure all warning and caution labels are legible and properly attached to the machine.
- During operation, attention shall be paid to other persons, especially children.
- Before use all covers and doors shall be put in the positions specified in the instructions.
- When leaving unattended, secure against unintentional movement.
- The machine shall only be operated by instructed and authorized persons.
- When leaving unattended, switch off or lock the main power switch to prevent unauthorized use.
- Only chemicals recommended by the manufacturer shall be used.
- This appliance has been designed for use with the brushes specified by the manufacturer. The fitting of other brushes may affect its safety.
- Do not use on surfaces having a gradient of over 2 degrees.

READ AND SAVE THESE INSTRUCTIONS

MESURES DE SÉCURITÉ IMPORTANTES

Lors de l'utilisation d'un appareil à batteries, il est nécessaire de respecter systématiquement des mesures de sécurité de base, comme suit :

PRENEZ NOTE DE TOUTES CES MESURES AVANT D'UTILISER CETTE MACHINE.

⚠ AVERTISSEMENT: Pour réduire les risques d'incendie, de chocs électriques, ou de blessures :

N'utiliser cette machine qu'en intérieur. Ne jamais l'utiliser à l'extérieur ou dans la pluie.

Utiliser cet appareil conformément aux instructions du présent manuel uniquement. N'utiliser que les composants et les accessoires conseillés par le fabricant.

Lorsque la machine ne **fonctionnant pas correctement**, a fait l'objet d'une chute ou d'une détérioration, a été laissée à l'extérieur, est tombée dans l'eau, la retourner au centre de service agréé.

Ne pas opérer la machine lorsque les conduits de ventilation sont bloqués. Débarrasser les débris des conduits, car ils peuvent réduire l'écoulement d'air.

Cette machine **n'est pas** adaptée au ramassage de poussières dangereuses

Ne pas l'utiliser près de liquides, de poussières ou de vapeurs inflammables.

L'entretien et les réparations de la machine **doivent être effectuées** par un personnel qualifié.

Si de la mousse ou du liquide sort de la machine, **la mettre hors tension immédiatement.**

Déconnecter les batteries avant de nettoyer la machine ou de la soumettre à un entretien.

Avant de se débarrasser de la machine, **il est nécessaire** de retirer les batteries et de les jeter correctement.

S'assurer que toutes les plaques d'avertissement ou de précaution **sont lisibles et fixées correctement** sur la machine.

Durant la manoeuvre de la machine, prendre garde aux personnes environnantes et notamment aux enfants.

Avant l'utilisation de la machine, veiller à positionner tous les couvercles et portes comme indiqué dans les instructions.

Lorsque la machine est laissée sans surveillance, s'assurer qu'elle ne se déplace pas de manière accidentelle.

Cette machine ne doit être manoeuvrée que par un personnel expérimenté et qualifié.

Lorsque la machine est laissée sans surveillance, la mettre hors tension ou verrouiller l'interrupteur principal afin d'empêcher un emploi non autorisé.

Seuls les produits chimiques recommandés par le fabricant doivent être utilisés.

Cette machine a été conçue pour être utilisée avec des brosses spécifiées par le fabricant.

L'utilisation d'autres brosses peut affecter sa sûreté.

N'employez pas sur des surfaces ayant un gradient de plus de 2 degrés.

CONSERVER CES INSTRUCTIONS

Safety

Hazard Intensity Level

The following symbols are used throughout this guide as indicated in their descriptions:

There are three levels of hazard intensity identified by signal words -**WARNING** and **CAUTION** and **FOR SAFETY**. The level of hazard intensity is determined by the following definitions:

WARNING:

WARNING - Hazards or unsafe practices which COULD result in severe personal injury or death.

CAUTION:

CAUTION - Hazards or unsafe practices which could result in minor personal injury or product or property damage.

FOR SAFETY: To identify actions which must be followed for safe operation of equipment.

Report machine damage or faulty operation immediately. Do not use the machine if it is not in proper operating condition. Following is information that signals some potentially dangerous conditions to the operator or the equipment. Read this information carefully. Know when these conditions can exist. Locate all safety devices on the machine. Please take the necessary steps to train the machine operating personnel.

FOR SAFETY:

DO NOT OPERATE MACHINE:

Unless Trained and Authorized.

Unless Operation Guide is Read and understood.

In Flammable or Explosive areas.

In areas with possible falling objects

WHEN SERVICING MACHINE:

Avoid moving parts. Do not wear loose clothing; jackets, shirts, or sleeves when working on the machine. Use manufacturer approved replacement parts.

WARNING:

Batteries emit hydrogen gas. Explosion or fire can result. Keep sparks and open flame away. Keep solution tank in raised position when charging. Keep sparks and flames away from the batteries. Do not smoke around batteries.

WARNING:

Disconnect batteries before working on machine. Only qualified personnel should work inside machine. Always wear eye protection and protective clothing when working on or near batteries. Avoid skin contact with the acid contained in the batteries.

WARNING:

Never allow metal to lie across battery tops.

Les symboles ci-dessous sont utilisés à travers ce manuel comme illustré dans leurs descriptions :

DEGRÉS DE RISQUES EN CAS DE DANGER

Il existe trois degrés de risques identifiés par les termes signalétiques –**AVERTISSEMENT** et **ATTENTION** et **POUR VOTRE SÉCURITÉ**. Le degré de risque est défini de la manière suivante:

AVERTISSEMENT:

AVERTISSEMENT - Dangers ou méthodes dangereuses qui POURRAIENT provoquer de graves blessures ou entraîner la mort.

ATTENTION:

ATTENTION - Dangers ou méthodes dangereuses qui pourraient provoquer des blessures légères ou une détérioration du produit ou des biens immobiliers.

POUR VOTRE SÉCURITÉ: ce signe permet d'identifier les mesures de précaution à prendre pour assurer un bon fonctionnement du matériel.

Rendre compte immédiatement d'une défaillance ou d'une détérioration de la machine. Ne pas utiliser la machine si celle-ci ne fonctionne pas correctement. Lire soigneusement les informations ci-dessous signalant certains dangers potentiels pour l'opérateur de la machine. L'opérateur doit être absolument au courant de ces dangers potentiels. Localiser tous les dispositifs de sécurité sur la machine. Il est conseillé de prendre les mesures nécessaires pour former le personnel opérateur.

POUR VOTRE SÉCURITÉ:

NE PAS MANOEUVRER LA MACHINE:

Lorsqu'on n'est pas expérimenté ou qualifié.

Lorsque le guide d'utilisation n'est pas été lu ou compris.

Dans des zones inflammables ou explosives.

Dans des zones où des objets peuvent tomber.

LORS DE L'ENTRETIEN DE LA MACHINE:

Éviter les parties amovibles. Ne pas porter de vêtements amples, tels que des vestes, des chemises ou des vêtements avec manches lors de l'utilisation de la machine. Utiliser les pièces détachées homologuées.

AVERTISSEMENT:

Les batteries émettent le gaz d'hydrogène. L'explosion ou le feu peut résulter. Étincelles de subsistance et flamme nue loin. Compartiment de batterie de subsistance ouvert en chargeant. Étincelles et flammes de subsistance loin des batteries. Ne fumez pas autour des batteries.

AVERTISSEMENT:

Déconnecter les batteries avant de travailler sur la machine. La machine ne doit être confiée qu'à un personnel qualifié. Porter systématiquement des lunettes et des vêtements de protection lors d'une intervention sur les batteries ou aux alentours. Éviter tout contact de la peau avec l'acide contenu dans les batteries.

AVERTISSEMENT:

Ne jamais placer d'objets métalliques sur le dessus des batteries.

Operations

Technical Specifications

ITEM	DIMENSION/CAPACITY
Nominal Power	1260 W
Rated Voltage	36 Volts DC
Rated Amperage	35 amps
Batteries	3 X12 Volt 130-195-215 AH @ 20 hr. rate
Battery Compartment Dimensions	23.5 in. x 15.5 in. x 16.5 in. tall (600 mm x 400 mm x 420 mm)
Propelling Motor	.5 HP (373 W)
Mass (GVW)	889 lbs (403 kg)
Weight Empty Without Batteries	340 lbs (154 kg)
Solution Control	Metered flow with automatic shut-off in neutral and reverse
Spray Pump Pressure	100 psi (688 Kpa)
Solution Capacity	19.4 gal (74 Liter)
Spray Jets - Interim	2 Jets with total flow of 0.24 gal/min (0.9 Liter/min)
Spray Jets - Extraction	2 Jets with total flow of 1.05 gal/min (4.0 Liter/min)
Recovery Capacity	17.5 gal (66 Liter)
Vacuum Motors	1 x .75 Hp (560 W)
Scrub Brush Diameter	3.38" Inch (85.5 mm)
Scrub Brush Motor	1 x .5 Hp (375 W)
Scrub Brush Pressure	Floating
Scrub Brush Speed	1084 rpm
Tires	9 in. (228mm) Solid Gray non-marking
Foundation Pressure	503 psi (3.5 Mpa)
Maximum (Transport) Speed	Propel = 252 Ft/min (4.6 Km/hr)
Scrubbing Speed	Interim = 110 Ft/min (2.0 Km/hr) Extract = 55 Ft/min (1.0 Km/hr)
Frame Construction	Powder coated steel
Minimum Aisle U-Turn Width	56 in. (1.4 Meter)
Maximum Rated Climb And Descent Angle	6 degrees

Technical Specifications

ITEM	MEASURE
Height	43 inches (1100 mm)
Length	54 inches (1400 mm)
Width	27 inches (700 mm)
Width of scrub path	20 inches (500mm)

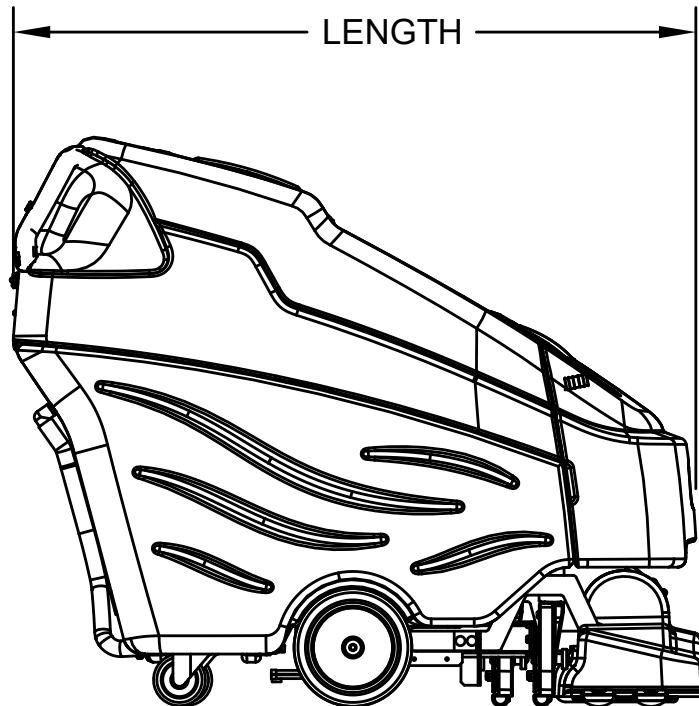
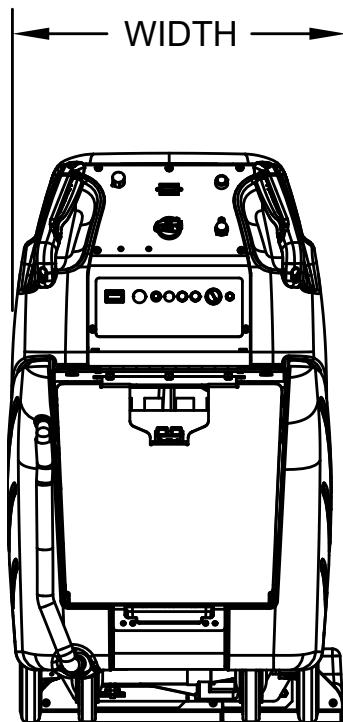

SPECIAL NOTES:

The sound pressure level at the operator's ear was measured to be 69.5dBA. This was a near field, broadband measurement taken in a typical industrial environment on a tile floor. This appliance contains no possible source of impact noise. The instantaneous sound pressure level is below 63 Pa. The weighted root mean square acceleration at the operator's arms was measured to be below 2.5m/s². This was a tri-axial, third-octave-band measurement made during normal operation on a composite tile floor. The measurement and related calculations were made in accordance with ANSI S3.34-1986.

⚠ WARNING:

This appliance is not intended for use by persons (including children) with reduced physical, sensory or mental capabilities, or lack of experience and knowledge, unless they have been given supervision or instruction concerning use of the appliance by a person responsible for their safety. Children should be supervised to ensure that they do not play with the appliance.

⚠ AVERTISSEMENT:

Cet appareil n'est pas prévu à l'usage des personnes (enfants y compris) avec des possibilités physiques, sensorielles ou mentales réduites, ou le manque d'expérience et de connaissance, à moins qu'ils aient été donnés la surveillance ou l'instruction au sujet de l'utilisation de l'appareil par une personne chargée de leur sûreté. Des enfants devraient être dirigés pour s'assurer qu'ils ne jouent pas avec l'appareil.

Operations

How This Machine Works

The Machine is a battery powered, self-propelled Carpet Maintainer and Carpet Extractor intended for commercial use.

The machine is designed to maintain your carpet using the Encapsulating Interim Carpet Cleaning Process. By using the Interim Carpet Maintainer in conjunction with Windsor Red Carpet Encapsulating Interim Cleaning (W450-4) or Encapsulating Interim Cleaning with Carpet Protection (W455-4) chemical solution, you can perform a regular light cleaning and grooming of your carpet very quickly, and have the carpet dry and ready for traffic within 30 minutes.

The machine is also designed to restore your carpet using carpet extraction chemicals. The machine is designed to apply cleaning solution onto carpeted floor, scrub the carpet with two counter-rotating brushes, then vacuum the soiled water back into the recovery tank.

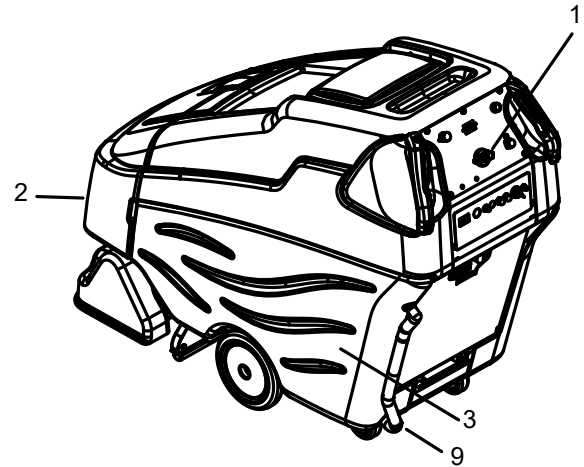
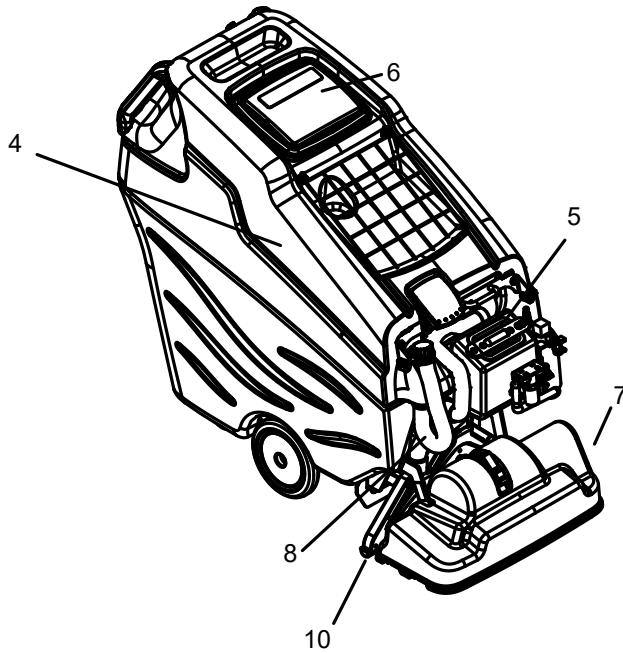

Components

- | | |
|------------------------------|------------------------|
| 1. Control Panel-Drive/Scrub | 6. Recovery Dome |
| 2. Front Cover | 7. Scrub Deck |
| 3. Solution Tank | 8. Recovery Drain Hose |
| 4. Recovery Tank | 9. Solution Drain Hose |
| 5. Solution Fill Cover | 10. Vacuum Shoes |

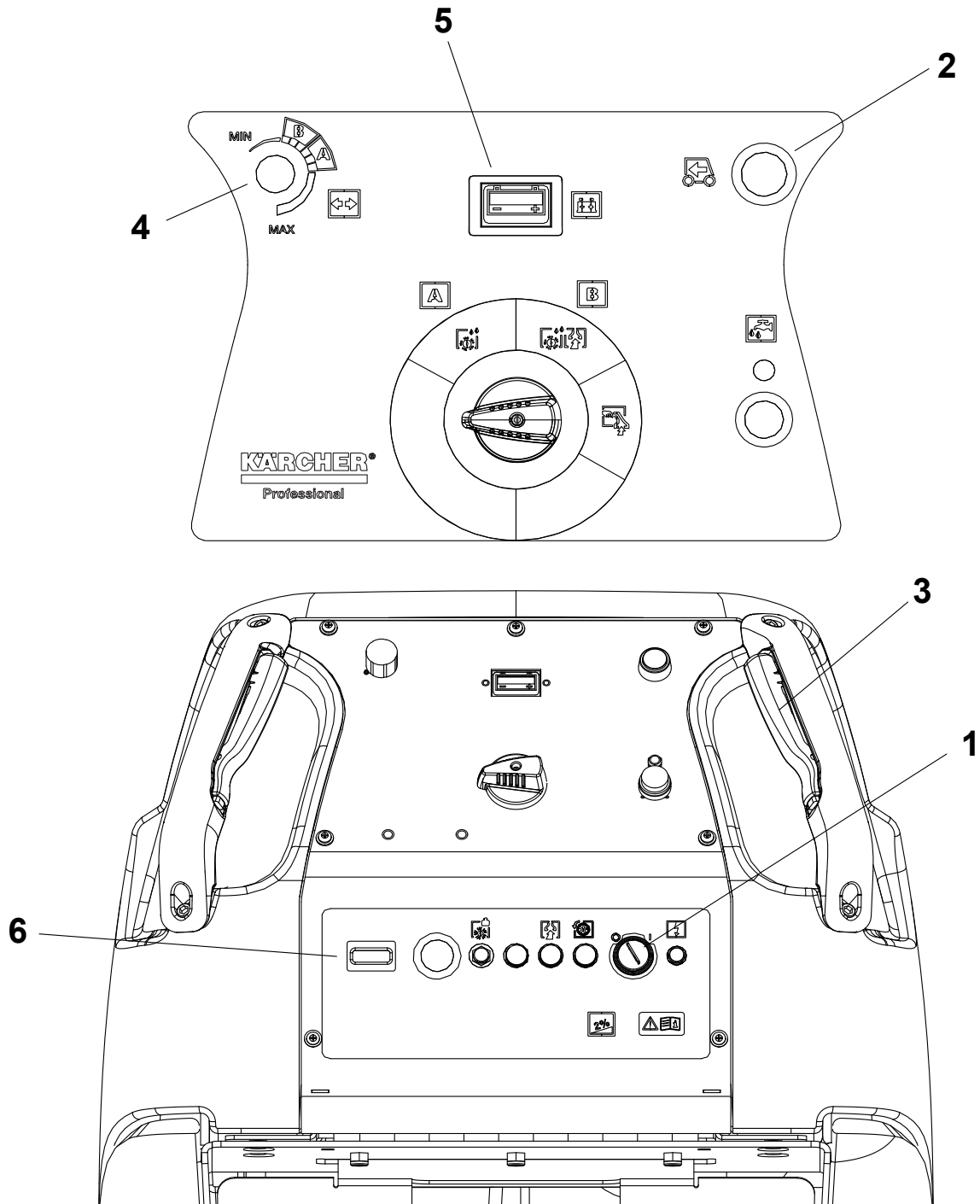

Drive Controls

- | | |
|----------------------|--------------------------------|
| 1. Key Switch | 4. Speed Control Knob |
| 2. Reverse Switch | 5. Battery Discharge Indicator |
| 3. Throttle Switches | 6. Hour Meter |

1. Key Switch

Controls the power for machine functions.

To turn the machine power on, rotate key clockwise.

To turn the machine off, rotate key counterclockwise.

2. Reverse Button

Controls the direction of travel of the vehicle.

To travel in reverse, press the button and press either of the throttle switches.

To travel forward, release the button and press either of the throttle switches.

3. Throttle Switches

Propel the vehicle with the speed control knob setting selected. Pressing either of the switches causes the machine to travel in the direction selected by the Reverse Button.

To travel, press either of the throttle switches.

To stop travel, release both throttle switches.

4. Speed Control Knob

Controls the speed of the machine. Speed range B is intended for carpet extraction. Speed A is intended for interim carpet cleaning. Faster speeds are recommended for transport only, not scrubbing.

To increase speed, turn the knob clockwise.

To decrease speed, turn the knob counter clockwise.

Speeds can be adjusted at any time, whether machine is moving or not.

5. Battery Discharge Indicator

Indicates the charge level of the batteries.

The meter display is divided into 10 vertical bars. All bars illuminated indicate full charge. Bars flashing near the left side indicate the batteries should be charged. Further operation of the machine could damage the machine and the batteries. Bars flashing also indicate that machine has been left unattended with key on for more than 15 minutes. Turn key off then on to reset.

6. Hour Meter

Records the number of hours the machine has been in operation (scrubbing). This information is useful in determining when to service the machine.

Operations

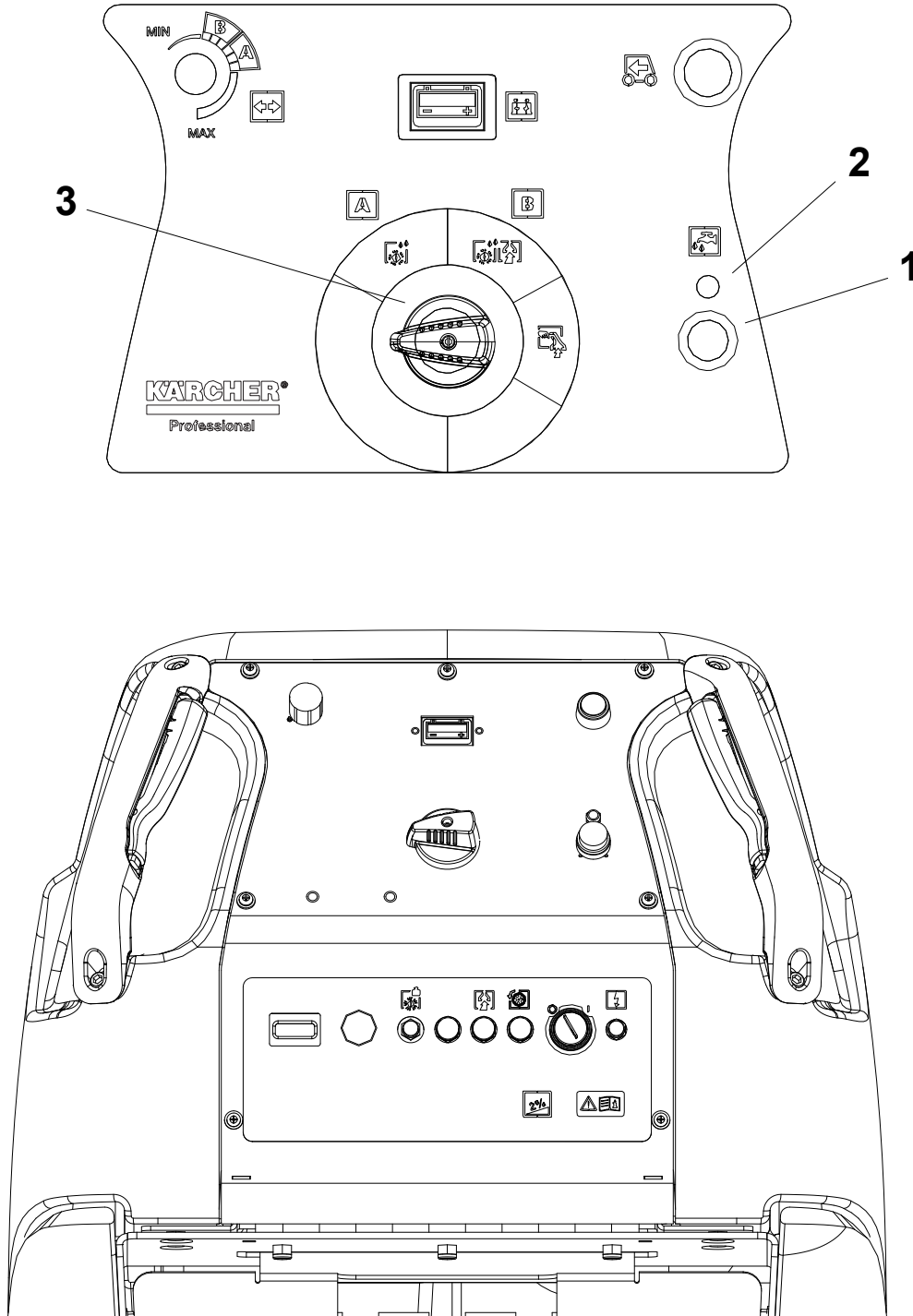

Scrub Controls

1. Solution Pump Switch
2. Solution Pump Indicator
3. Function Switch

1. Solution Pump Switch

Controls power to the spray pump.

If the throttle is in neutral, or reverse control button is in reverse position, the flow is automatically interrupted. This feature prevents application of solution without scrubbing it into carpet.

2. Solution Pump Indicator Light

The solution pump indicator light is illuminated green when the pump is on.

3. Scrub Deck Rotary Switch (Basic)

Raises and lowers the scrub deck, and turns the scrub brush motors on and off, and controls the solution solenoids.

For interim or "A" mode, rotate the function knob to the "A" position. The scrub deck will lower and the scrub motor will turn on and the interim solenoid will open and spray will flow through the interim jets. The brush motor will automatically turn off in neutral. The interim solenoid will shut off in neutral or reverse.

To raise the deck, turn off the brush motor and solenoid(s). Rotate the knob to the off position to the far counter clockwise position.

For extraction or "B" mode, rotate the function knob to the "B" position. The scrub deck will lower and the scrub motor will turn on and the extraction solenoid and interim solenoid will open and spray will flow through the extraction and interim jets and the vacuum motor will run. The brush motor will automatically turn off in neutral. The extraction and interim solenoid will shut off in neutral or reverse.

To raise the deck, turn off the brush motor and solenoid(s). Rotate the knob to either the off position to the far counter clockwise position, or rotate the knob to the far clockwise position to the accessory mode so that the vacuum motor continues to run to keep any excess soiled solution from dripping back onto the floor.

To use the machine with an accessory hand tool or wand rotate the knob fully clockwise to the accessory position. Only the vacuum motor and pump will run. Connect the solution hose of the accessory tool to the solution accessory port. The fitting is 1/8" male quick disconnect. If needed to adapt to 1/4" male quick disconnect (see Suggested Spare Parts for part number).

To connect the vacuum hose, disconnect the hose assembly from the lower connection of the "Y" tube junction. Use adapter to join the two hose cuffs together (See Accessories page).

Operations

Machine Operation

Pre-Run Machine Inspection

Do a pre-run inspection to find possible problems that could cause poor performance or lost time from breakdown. Follow the same procedure each time to avoid missing steps.

NOTE: See maintenance section for pre-run machine inspection checklist items.

Starting Machine

NOTE: Perform pre-run machine check before operating machine.

FOR SAFETY: Before starting machine, make sure that all safety devices are in place and operating properly.

1. Turn the machine power on by turning key switch clockwise to the "I" (on) position.
2. Check the position of the Direction Control Button to make sure the machine will travel in the direction intended.
3. Check the position of the speed control knob to make sure the machine will travel at the intended speed.
4. Press either throttle switch.

Emergency Stop Procedures

1. Release both the throttle switches.
2. Turn machine power off with key switch by turning key switch counterclockwise to the "o" (off) position.

Filling Solution Tank

FOR SAFETY: Before leaving or servicing machine; stop on level surface, turn off machine and remove key.

1. Turn the machine power off.
2. Remove the front cover and the solution fill lid.
3. Fill the solution tank with clean water. (See the Technical Specifications chart for exact capacity). The water must not be hotter than 140° F (60°C) to prevent damage to the tank.
4. Replace the solution fill lid and front cover.

WARNING:

Flammable materials can cause an explosion or fire. Do not use flammable materials in the tanks.

AVERTISSEMENT:

Les matières inflammables peuvent provoquer une explosion ou un incendie. Ne pas utiliser de matériaux inflammables dans les réservoirs.

Normal Scrubbing

Plan the scrubbing pattern in advance.

For efficient operation, the runs should be the longest possible without turning, stopping, or raising or lowering scrub deck. The longest track is around the perimeter of the area to be cleaned and a collapsing rectangle pattern is most efficient.

In order to achieve the best possible results, the area which is to be cleaned, should be vacuumed before scrubbing. Large debris, strings and wire must be removed to prevent being caught in brushes.

If the machine is allowed to stand in neutral with the scrub deck down for more than 2 seconds, the solutions flow stops and brush motor stops. When forward travel is resumed, the solution flow and the scrub brush motor will continue. Overlap the brush path and avoid transporting over previously cleaned areas.

Recommended Scrubbing Path:

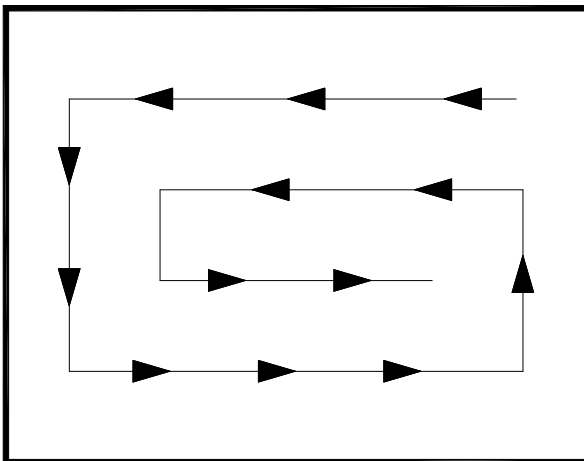

To Begin Scrubbing

⚠ WARNING:

When operating the machine around people, pay close attention for unexpected movement. Use extra caution around children.

⚠ AVERTISSEMENT:

Lorsque vous utilisez la machine en présence de gens, portez une attention particulière aux mouvements inattendus. Soyez plus prudent, surtout en présence d'enfants.

1. Turn machine power on.
2. Position rotary switch to the position matching the process to be performed, and the chemical that was added to the solution tank either interim or extraction/cleaning.
3. Check position of reverse button and the position speed control knob so that the machine is set to travel in the direction and the speed intended.
4. Drive machine forward by pressing either throttle switch to begin scrubbing.

To Stop Scrubbing

1. While scrubbing turn off the pump switch to stop spraying solution. Continue to scrub and recover the solution for an additional pass.
2. Allow the throttle switches to return to neutral.
3. Rotate the selector switch to the accessory position so that the vacuum motor continues to run and evacuate the system. This will also raise the deck and vacuum shoes.
4. Turn the rotary switch to the off position by rotating the selector switch clockwise. Turn machine power off.

FOR SAFETY: Before leaving or servicing machine: stop on level surface, turn off machine and remove key.

FOR SAFETY: When using machine, go slow on inclines and slippery services.

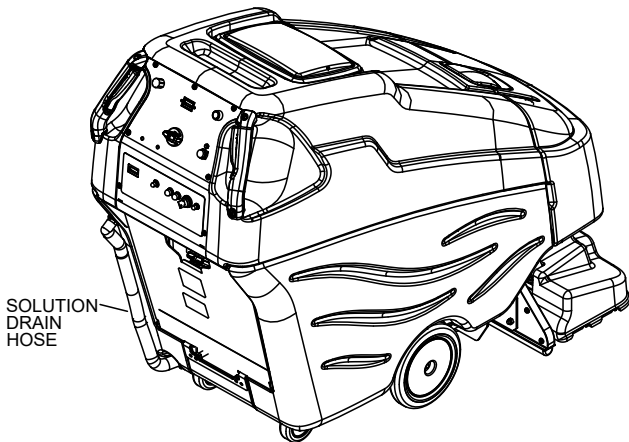

Emptying And Cleaning Solution Tank

1. Park the machine next to a floor drain. Drain hose is at the rear of the machine.
2. Turn the machine power off.
3. Remove the top of the hose from the barb mount and lower hose in direction of the drain. Do not stand in front of end of hose. Solution will come out with force.
4. Remove the front cover and solution fill cover.
5. Flush the solution tank out with clean water and run several gallons of clean water through both spray jet systems. Do not use water hotter than 140°F (60°C) to clean tank or damage may occur.
6. Replace the drain hose to the barbed fitting.
7. If machine is to be stored, leave the solution fill cover off.

Emptying And Cleaning Recovery Tank

1. Park the machine next to a floor drain. Drain hose is at the front of the machine.
2. Turn the machine power off.
3. Remove front cover. Remove hose assembly from mounting hook. Place the end of the hose at the drain and slowly remove the cap. Do not stand in front of hose end. Soiled solution will come out with force.
4. Remove dome lid.
5. Flush the recovery tank out with clean water. Do not use water hotter than 140°F (60°C) to clean tank or damage may occur.
6. Replace the drain hose cap and place hose back on hook. Replace front cover.
7. If machine is to be stored, leave the recovery dome off.

Maintenance

Service Schedule

Maintenance	Before Each Work Period	After Each Work Period	50 HRS	100HRS	200HRS
Check water level of batteries after charging; add distilled water if necessary.	*				
Check brushes for proper installation.	*				
Check for securely attached drain hose, plug and cap.					
Check that solution fill lid seals tightly	*				
Visually check for damaged or worn tires.	*				
Check all throttle, direction and speed controls for proper operation.	*				
Observe spray pattern and clean jets if necessary.	*				
Prime chemical system for 30 seconds for each chemical.	*				
Clean brushes and check wear.		*			
Remove bearing cap from end of brush. Clean bearing and cap.		*			
Clean underside of scrub deck.		*			
Clean out solution tank.		*			
Clean out recovery tank.		*			
Clean and inspect solution filter strainer.		*			
Store with solution fill lid and recovery dome off tanks to allow tanks to dry.		*			
Clean outside of tank, check for damage.		*			
Charge batteries.		*			
Flush chemical system		*			
Clean off top of batteries.			*		
Check battery cells with hydrometer.			*		
Check battery connections are tight.			*		
Clean battery cases and battery compartment.				*	
Grease appropriate zerks (grease fittings).				*	
Clean pivot points on scrub deck.					*
Check all motors for carbon brush wear.					*
Check motor commutators.					*

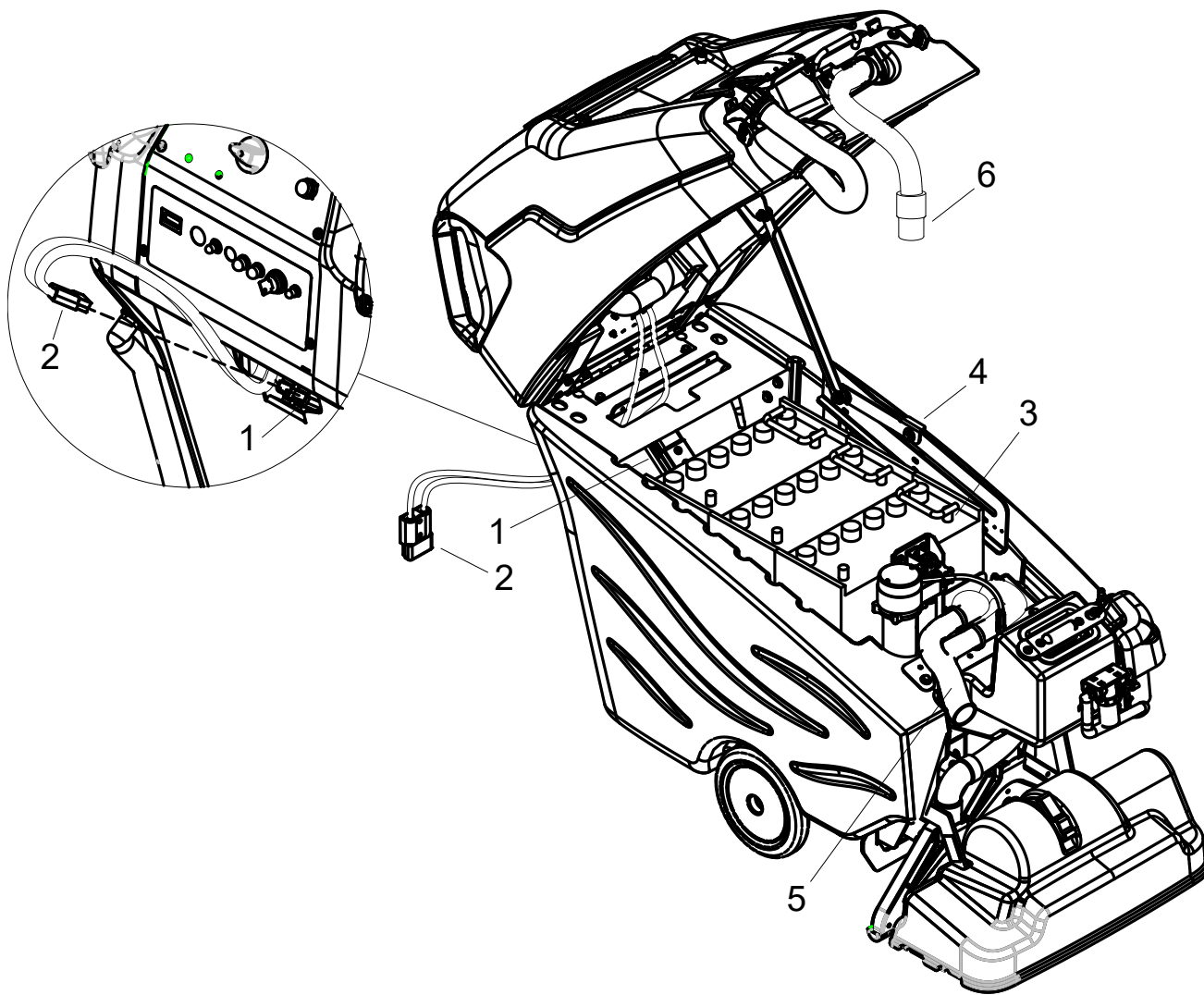

Batteries

- 1. Battery Connector
- 2. Battery Connector
- 3. Batteries

- 4. Prop Rod and Catch
- 5. "Y" Tube
- 6. Recovery Hose

Maintenance

Batteries (Wet Cell Only)

The batteries provide the power to operate the machine. The batteries require regular maintenance to keep them operating at peak efficiency.

The machine batteries will hold their charge for long periods of time, but they can only be charged a certain number of times. To get the greatest life from the batteries, charge them when their charge level reaches 25% of a full charge. Use a hydrometer to check the charge level.

Do not allow the batteries to remain in a discharged condition for any length of time. Never expose a discharged battery to temperatures below freezing. Discharged batteries will freeze causing cracked cases. Do not operate the machine if the batteries are in poor condition or if they have a charge level below 25% (specific gravity below 1.155).

Keep all metallic objects off the top of the batteries, as they may cause a short circuit. Replace worn or damaged cables and terminals.

Check the electrolyte level in each battery cell before and after charging the batteries. Never add acid to the batteries, use distilled water. Do not allow water level to fall below the battery plates. Portions of plates exposed to air will be destroyed. Do not overfill. Keep plugs firmly in place at all times.

⚠ CAUTION:

When servicing machine, avoid contact with battery acid.

⚠ ATTENTION:

Lors de l'entretien de la machine, évitez tout contact avec l'acide de batterie.

⚠ WARNING:

Batteries emit hydrogen gas. Explosion or fire can result. Keep sparks and open flame away. Keep covers open when charging.

⚠ AVERTISSEMENT:

Les batteries émettent du gaz hydrogène. Une explosion ou un incendie peut en résulter. Maintenez les étincelles et les flammes nues à l'écart. Gardez les carters ouverts lors du chargement.

⚠ WARNING:

Wear eye protection and protective clothing when working with batteries.

⚠ AVERTISSEMENT:

Portez des lunettes de protection et des vêtements de protection lorsque vous travaillez avec des batteries.

⚠ WARNING:

Charge batteries in a well ventilated area.

⚠ AVERTISSEMENT:

Chargez les batteries dans un endroit bien ventilé

Battery Maintenance

1. When cleaning the batteries, use a solution of baking soda and water. Do not allow the cleaning fluid to enter the battery cells, electrolyte will be neutralized.
2. Maintain the proper electrolyte level in each battery cell. If a cell should accidentally overflow, clean immediately.
3. Wipe off the top of the batteries at least once a week.
4. Test battery condition with a hydrometer at least once a week.
5. Ensure that all connections are tight and all corrosion removed.
6. Every 4 to 6 months, remove that batteries from the machine and clean the battery cases and battery compartment.

Checking Battery Specific Gravity

Use a hydrometer to check the battery specific gravity.

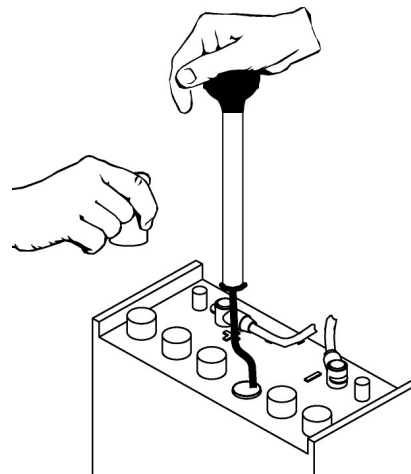

NOTE: Do not take readings immediately after adding distilled water, if the water and acid are not thoroughly mixed, the reading may not be accurate.

Check the hydrometer readings against this chart.

SPECIFIC GRAVITY @ 80° F (27°C)	BATTERY CONDITION
1.265	100% CHARGED
1.225	75% CHARGED
1.190	50% CHARGED
1.155	25% CHARGED
1.120	DISCHARGED

NOTE: If the readings are taken when the battery electrolyte is any temperature other than 80°F (27°C), the reading must be temperature corrected.

To find the corrected specific gravity reading when the temperature of the battery electrolyte is other than 80°F (27°): Add (+) to the specific gravity reading 0.004 (4 points), for each 10°F (6°C) above 80° (27°C).

Subtract (-) from the specific reading 0.004 (4 points), for each 10°F (6°C) below 80°F (27°C).

Charging Batteries

⚠ CAUTION:

When servicing machine, avoid contact with battery acid.

⚠ ATTENTION:

Lors de l'entretien de la machine, évitez tout contact avec l'acide de batterie.

⚠ WARNING:

Batteries emit hydrogen gas. Explosion or fire can result. Keep sparks and open flame away. Keep covers open when charging.

⚠ AVERTISSEMENT:

Les batteries émettent du gaz hydrogène. Une explosion ou un incendie peut en résulter. Maintenez les étincelles et les flammes nues à l'écart. Gardez les carters ouverts lors du chargement.

⚠ WARNING:

Wear eye protection and protective clothing when working with batteries.

⚠ AVERTISSEMENT:

Portez des lunettes de protection et des vêtements de protection lorsque vous travaillez avec des batteries.

⚠ AVERTISSEMENT:

Charge batteries in a well ventilated area.

Chargez les batteries dans un endroit bien ventilé

Use a 36 volt, 20 amp maximum output DC charger which will automatically shut off when the batteries are fully charged.

1. Empty recovery tank.
2. Stop the machine in a clean, well ventilated area next to the charger.
3. Turn "OFF" machine.

FOR SAFETY: Before leaving or servicing machine; stop on level surface, turn off machine and remove key.

4. Unplug the machine from the battery pack. Remove front cover. Disconnect recovery hose from "Y" tube. Raise recovery tank and verify prop rod latch is safely engaged.

⚠ WARNING:

Batteries emit hydrogen gas. Explosion or fire can result. Keep sparks and open flame away. Keep covers open when charging.

⚠ AVERTISSEMENT:

Les batteries émettent du gaz hydrogène. Une explosion ou un incendie peut en résulter. Maintenez les étincelles et les flammes nues à l'écart. Gardez les carters ouverts lors du chargement.

Maintenance

5. Check the electrolyte level in each battery cell. Before charging, add just enough distilled water to cover the plates. After charging is complete, add just enough distilled water to bring up the level to the indicator ring. If the water level is too high before charging, normal expansion rate of the electrolyte may cause an overflow resulting in a loss of battery acid balance and damage the machine.
6. Replace the battery caps, and leave them in place while charging.
7. Unplug the machine connector from the battery.

FOR SAFETY: When charging, connect the charger to the batteries before connecting the charger to the AC wall outlet. Never connect the charger to the AC wall outlet first. Hazardous sparks may result.

8. Plug the charger connector into the battery connector. Connect the charger AC plug to a wall outlet. The charger gauge should indicate that the batteries are charging.
9. When the batteries are fully charged, disconnect the charger from the AC wall outlet, then disconnect the charger from the batteries.
10. Connect the machine to the battery connector.
11. Check the electrolyte level. It should be up to the indicator ring. If necessary, add distilled water.
12. Lower recovery tank by safely disengaging the prop rod latch and slowly lowering. Replace the hose and "Y" tube connection. Replace front cover.

Changing Batteries

Stop the machine in a clean area next to the charger. Turn off machine.

FOR SAFETY: Before leaving or servicing the machine; stop on level surface, turn off machine and remove key.

1. Disconnect machine from battery pack.
2. Raise recovery tank and engage prop rod latch.
3. Disconnect main positive lead and secure cable terminals away from batteries.
4. Loosen both terminals on each jumper cable and remove one at a time.
5. Prepare a suitable site to place the batteries.
6. Attach suitable battery lifting device and lift batteries from the machine.

⚠ WARNING:

Batteries are a potential environmental hazard. Consult your battery supplier for safe disposal methods.

⚠ AVERTISSEMENT:

Les batteries constituent un danger potentiel pour l'environnement. Consultez le fournisseur de votre batterie pour connaître les méthodes d'élimination sûres.

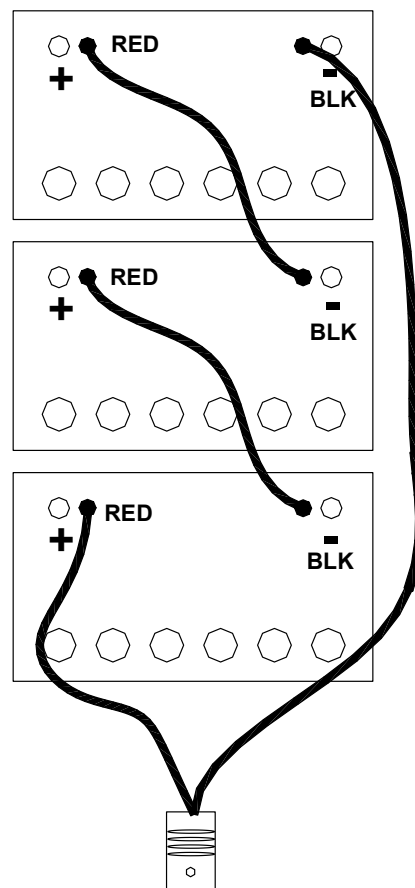

Rear of Machine

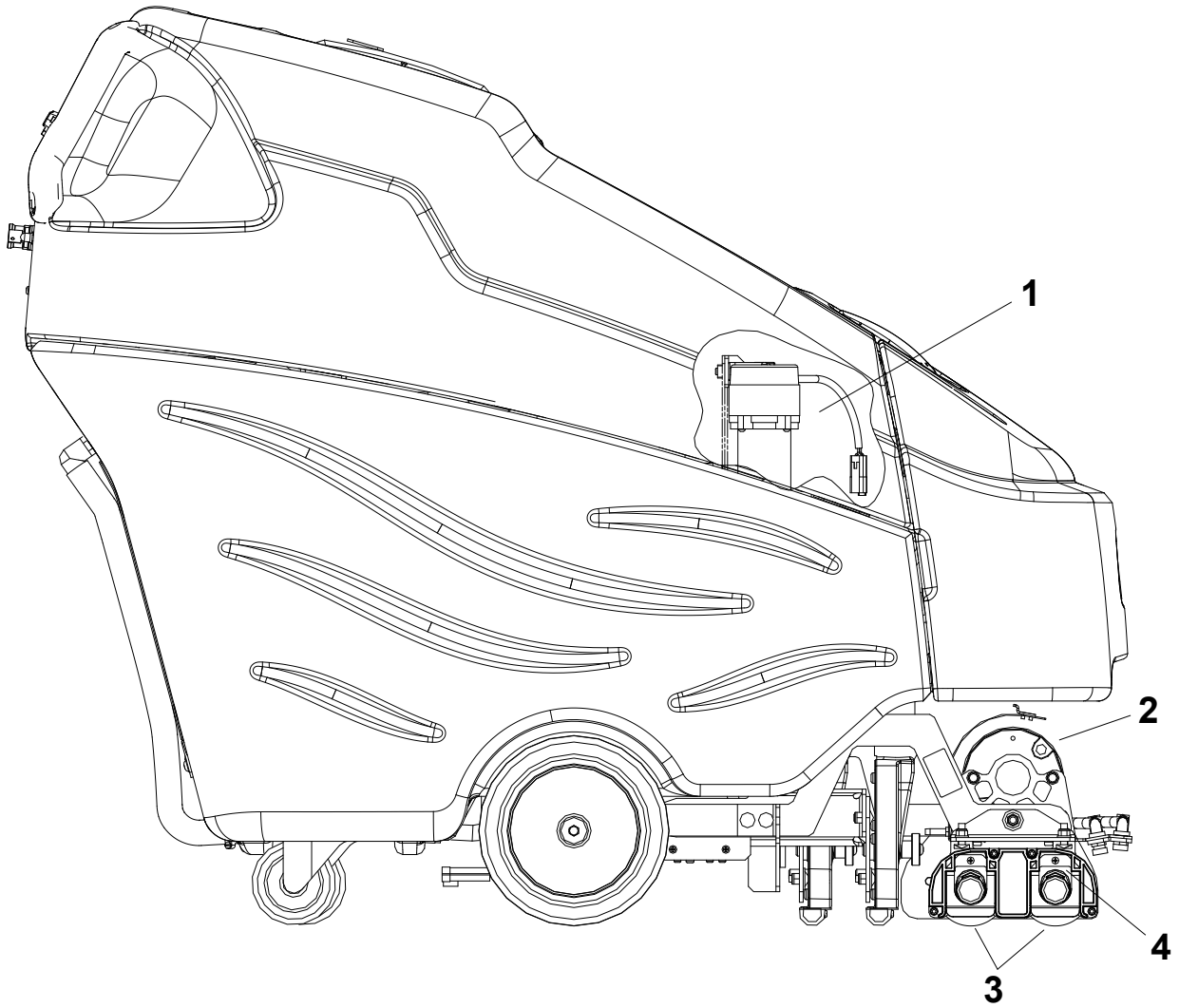

Scrub Deck

1. Scrub deck lift actuator
2. Scrub brush motor
3. Scrub brushes
4. Retaining clip

Maintenance

Scrub Head

The dual cylindrical scrub head is designed to scrub chemical into the carpet. The two counter rotating brushes raise the pile of the carpet, giving it a lush groomed appearance.

Maintenance

Scrub brushes should be exchanged front to back every 50 hours to ensure even wear. Scrub brushes should be replaced as a set when bristle length wears to height of yellow PerformAlert™ bristles

Scrub Brushes

Scrub Brush Removal

The scrub brushes are removed from the right side of the machine.

1. Raise the scrub deck to the storage position.
2. Pull out on the bottom of the retaining clip.
3. The brush assembly and end cap should drop down. Then pull the brush down far enough to clear the bottom of the housing.
4. Pull brush out with a rocking motion to free brush from drive hub.

Bearing Cleaning

1. Remove bearing cap from end of brush.
2. Clean cap and bearings.



Scrub Brush Replacement

1. Lift the drive side of the brush and push it onto drive hub until a positive stop is felt. The brush cannot be installed until the brush is fully seated on the drive hub.
2. Pull out on the bottom of the retaining clip.
3. Line up the end cap with the flats to each side.
4. Slide brush up into the retaining clip until it clicks in place.

Scrub Motor

WARNING:

Do not use a pressure washer to clean around the brush motors. Use tap pressure only.

AVERTISSEMENT:

N'utilisez pas de nettoyeur haute pression pour nettoyer autour des moteurs des brosses. Utilisez seulement la pression du robinet.

To Replace Scrub Brush Motor

1. With the scrub deck in the lowered position, remove the deck cover and disconnect brush motor wiring connector from harness.
2. Remove the motor and end bracket assembly from the deck.
3. Separate brush motor from end brackets.
4. Reverse to reassemble.

Brush Motor Carbon Brush Replacement

1. Scribe alignment mark on motor barrel to motor cap. Remove two bolts.
2. Remove end cap from motor.

NOTE: Motors contain two wave washers in cap. Do not lose these.

3. Release brush from spring tension. Remove screw connecting brush wire lead to brush holder. Clean brush holder to insure free movement.
4. Retract spring and install new brush. Install connector screw and lead.
5. When all new brushes are installed. Place all in retracted position, held into brush holder by spring tension.
6. Carefully place end cap onto bearing on motor shaft.

NOTE: Use care to assure wave washer alignment.

7. With end cap in partially installed position, release all brushes to contact position with motor commutator.

NOTE: Failure to insure all brushes are released will result in motor failure.

8. Reset end cap and realign with scribe marks on motor barrel. Reinstall the two attach bolts from cap into base.
9. Maintain alignment between motor barrel base and cap.

Maintenance

Actuator Scrub Deck Removal/Replacement

FOR SAFETY: Before leaving or servicing machine, stop on a level surface. Turn off machine.

1. Lower scrub deck. Remove the front cover and raise recovery tank.
2. Disconnect electrical connector.
3. Remove the clevis pin retaining the bottom of the actuator.
4. Remove the clevis pin retaining the top of the actuator.
5. Reverse for re-installation.

Scrub Deck Actuator Adjustment

The actuator will need to be adjusted when replaced.

To adjust the actuator:

1. While holding actuator barrel to prevent it from spinning, apply power to the actuator such that it is fully extended. Limit switch within actuator will stop it.
2. With actuator fully extended, attach to the top bracket.
3. At the bottom mount align the mounting hole with the center of the slot, turn the barrel in or out enough to align connection to bracket.
4. Connect actuator electrical plug.
5. Check travel of actuator during operation.

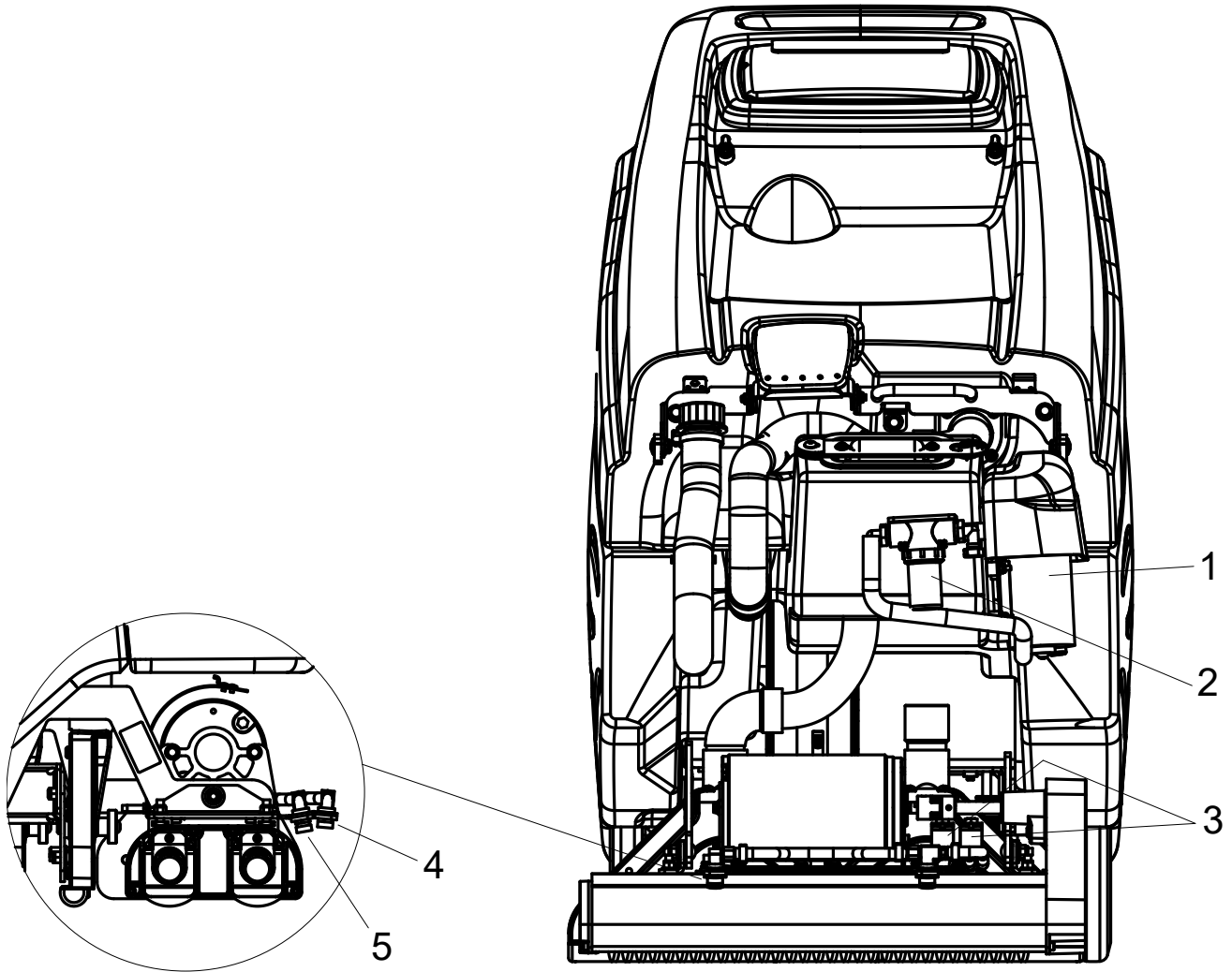

Solution Strainer & Pump

1. Pump
2. Solution Strainer
3. Solenoid Valves
4. Jets- Interim
5. Jets-Extraction

Maintenance

Solution Strainer

The solution strainer is located on the front of the machine under the front cover. The strainer protects the pump, solenoid valve and jets from debris. If there is little or no solution flow to the ground, check the strainer for debris. Clean the solution strainer. To remove the strainer, turn the bottom part of the strainer counterclockwise until the bottom is separated. Clean out the debris from the wire mesh and the bowl and re-assemble. Make sure the O-ring gasket is in place when re-assembled.

Pump

The pump is located on the front of the machine under the front cover. The pump delivers solution from the tank to the scrub deck.

To repair or replace pump:

1. Remove front cover.
2. Remove hoses connecting the pump.
3. Remove screws that secures pump to mounting plate.

Solenoid Valve

The solenoid valves is mounted on the front of the scrub deck, on left side.

The solenoid valves shuts off solution flow to jets whenever scrubbing stops or in reverse. To repair or replace solenoid valve, remove screws that secure it to deck.

Jets

The two sets of jets are located in front of the scrub deck.

The jets spray cleaning solution onto the carpet. The spray pattern should be checked regularly and if jets become clogged they should be cleaned or replaced immediately.

To clean jets:

1. Remove jet from jet body by rotating it counterclockwise.
2. Blow debris back through orifice if possible. Do not use pointed object to unplug jet. This will damage jet and cause improper spray pattern and solution flow through jets.
3. If jet cannot be cleaned by blowing debris back through its orifice, submerge jet in small container of acetic acid and let soak for up to six hours.
4. After soaking jet, use a soft brush to remove debris and rinse thoroughly.
5. Install jet in jet body by rotating it clockwise firmly into place.
6. For lower flow in extraction "B" other jets are available. (See Accessories page).

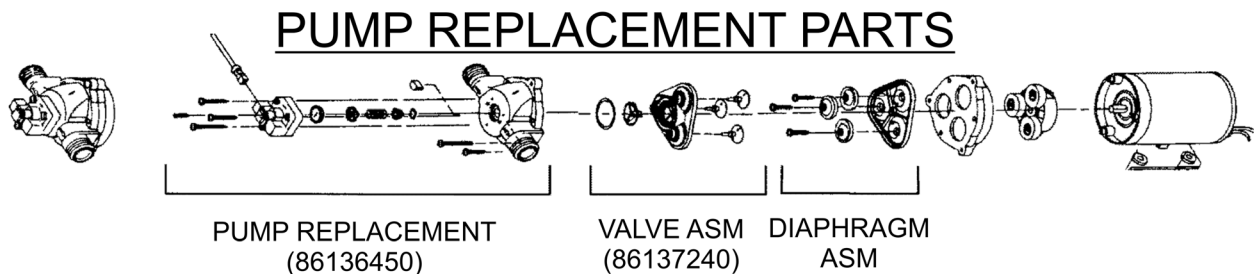

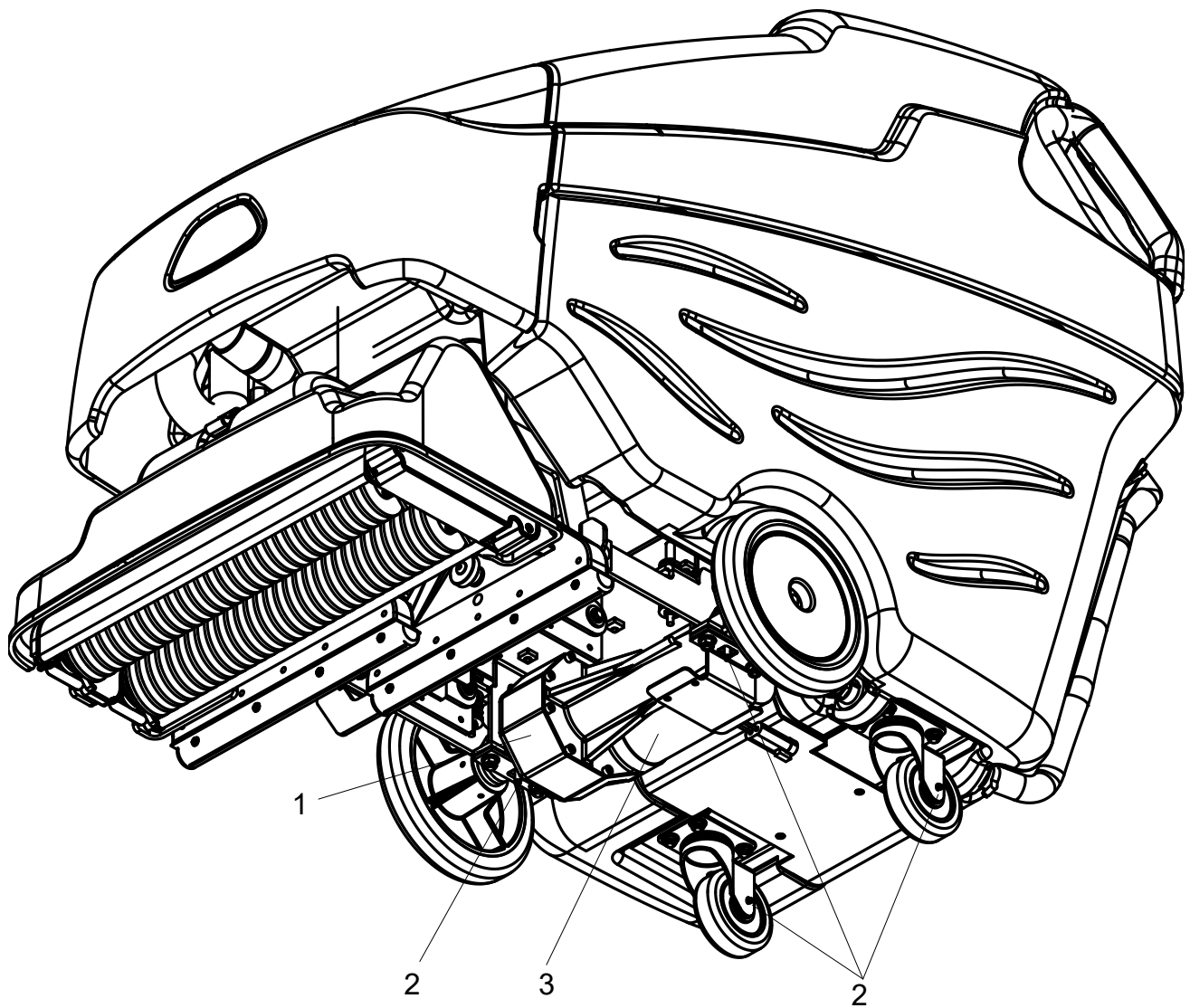

- Drive Assembly**
- 1. Drive Assembly
 - 2. Grease Points
 - 3. Drive Motor

Drive Assembly

Drive Motor Carbon Brush Replacement

⚠ WARNING:

Do not use a pressure washer to clean around the motors. Use tap pressure only.

⚠ AVERTISSEMENT:

N'utilisez pas de nettoyeur haute pression pour nettoyer autour des moteurs des brosses. Utilisez seulement la pression du robinet.

FOR SAFETY: Before leaving or servicing machine, stop on a level surface, turn off machine and remove key.

1. Disconnect batteries from machine.
2. Disconnect the electrical connection to the traction motor.
3. Remove brush cap.
4. Release brush from spring tension. Remove screw connecting brush wire lead to brush holder. Clean brush holder to insure free movement.
5. Install new brush and reinstall connecting screw and lead.
6. When all new brushes are installed. Place all in retracted position, held into brush holder by spring tension.
7. Carefully replace brush cap.

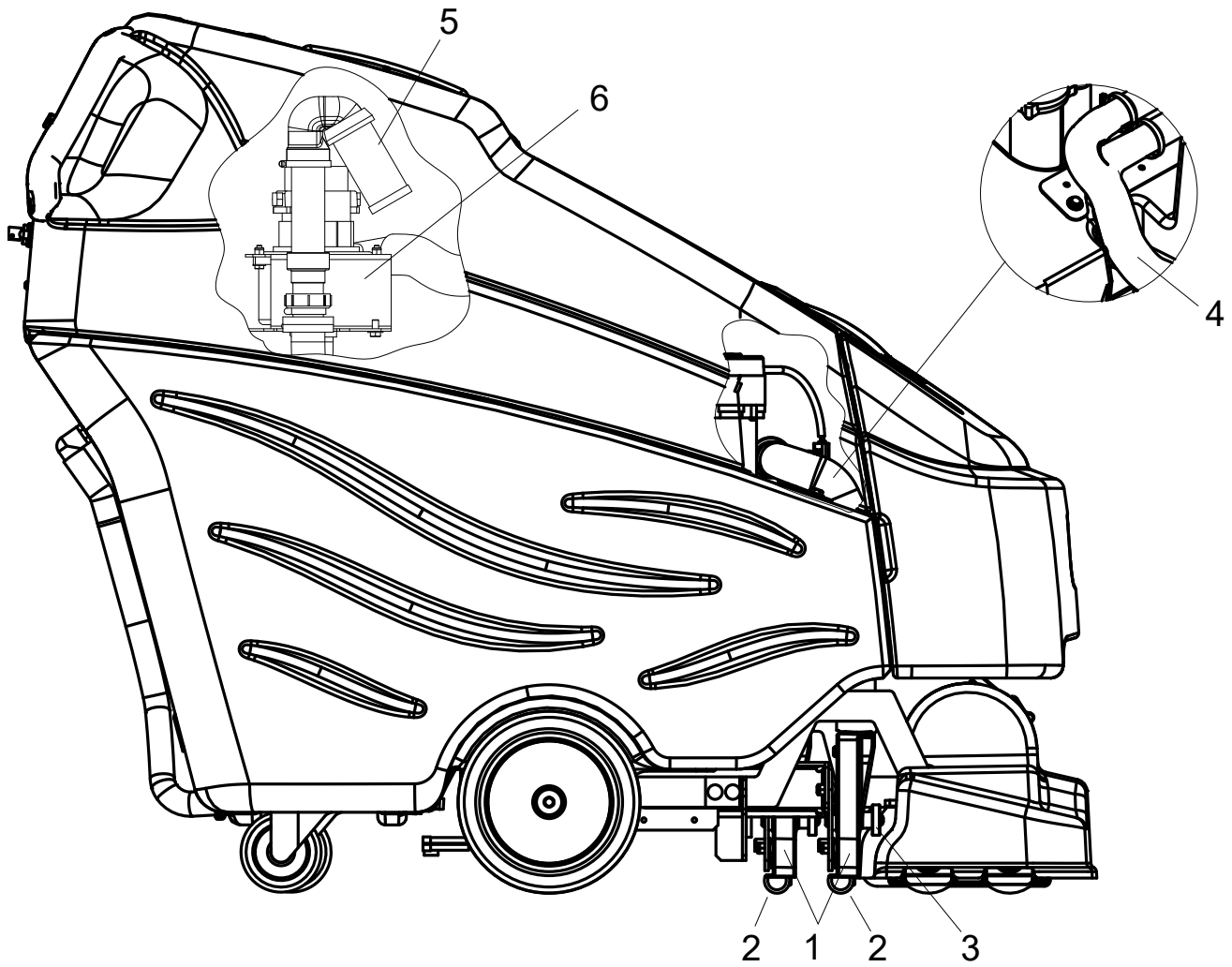

Vacuum

1. Vacuum Shoes
2. Vacuum Glides
3. Vacuum Shoe Retainer Knobs
4. "Y" Tube
5. Float Ball And Screen
6. Vacuum Motor

Vacuum Shoes

The dual offset vacuum shoes are designed to extract soiled solution from the carpet. The plastic vacuum shoe glides minimize wear to flooring.

Maintenance

The vacuum shoes should be removed and cleaned daily to ensure maximum recovery.

Vacuum Shoe Removal

1. Unscrew retainer knob from right side vacuum shoe.
2. Pull vacuum shoe forward until it is free from pivot pin.
3. Remove vacuum hose from top of vacuum shoe
4. Repeat to remove left side vacuum shoe.
5. Inspect or repair as necessary and reinstall.

To Clean Vacuum Shoes

1. With the vacuum shoes in the raised position, turn key switch "off".
2. Remove vacuum shoes.
3. Flush vacuum shoes from top with water. If necessary, clean blockage from narrow opening with a scraper or similar device.
4. Vacuum shoe glides may be removed for cleaning (or replaced) by removing the three pins that secure them to metal vacuum shoes.

Recovery Tank Float Shut-Off

When water is no longer being vacuumed from the floor and the vacuum fan is operating, the ball float has engaged. The vacuum motors will not vacuum water with recovery tank full. The recovery tank must be drained.

1. The float shut-off screen can be cleaned in or out of the machine.
2. To clean the float shut-off while it is inside the machine wipe material off screen then rinse. Check that the ball is also clean and moves freely.
3. To remove the float shut-off, grasp the elbow with one hand tilt and pull the float screen assembly to pull it off the elbow.
4. To install, place one hand on the elbow, and then tilt and push the float screen assembly over the elbow.

To Repair Or Replace Vacuum Motor(s)

1. Remove the front cover, drain the recovery tank.
2. Raise the recovery tank and safely engage the prop rod latch.
3. Disconnect electrical connector from the vacuum motor(s) and connecting hoses.
4. Unbolt the bracket and vacuum motor assembly and remove from tank.
5. Remove the vacuum motor from the bracket.
6. Reverse steps to install. Make sure the gaskets fit and seal properly as you reassemble.

Vacuum Motor Carbon Brushes

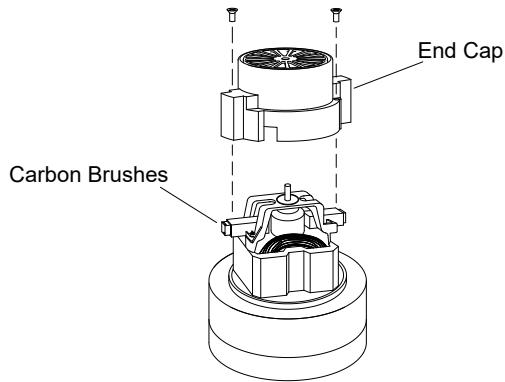

If armature commutator is grooved, extremely pitted or not concentric, the motor will need to be replaced or sent to a qualified service center.

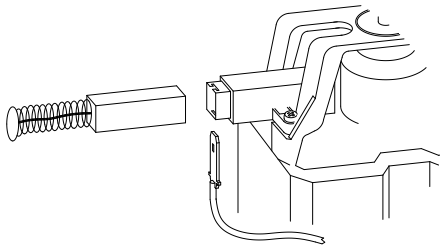

Important:

These brushes wear quicker as the length shortens due to increased heat. Spring inside brush housing will damage motor if brushes are allowed to wear away completely.

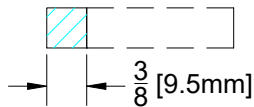

Periodically check the length of the carbon brushes. Replace both carbon brushes when either is less than $\frac{3}{8}$ " (9.5mm) long.

Transporting Machine

Pushing Machine

1. The machine may be pushed for short distances at speeds not to exceed 5 mph. Be careful to avoid damaging machine. The machine may be pushed by hand from the rear.

NOTE: To avoid damage caused by regenerative voltage, disconnect traction motor before towing or pushing machine.

Preparation For Loading /Unloading Trailer

Before loading or unloading machine from trailer, remove vacuum shoes to eliminate interference. Scrub head must be in the up position before loading.

NOTE: When transporting the machine on a trailer or in a truck, in addition to using tie-downs, be sure to block the tires to prevent the machine from rolling.

Machine Troubleshooting

PROBLEM	CAUSE	SOLUTION
No power to machine	Battery disconnected	Check all battery cable connections
	Battery cables corroded	Clean connections
	Faulty key switch	Replace switch
Little or no propel	Low battery charge	Charge batteries
	Machine turned on with propel trigger not in neutral position	Allow pedal to return to neutral. Restart
	Tripped circuit breaker	Reset circuit breaker and check brush
	Controller overheated	Allow cool down period
	Loose motor connection	Check wires and connections from controller to motor
	Faulty throttle circuit or potentiometer	Check wires and connections from throttle to controller and potentiometer resistance
	Faulty brake circuit	Check wires connections
Machine does not change speeds	Faulty speed control circuit or potentiometer	Check wires, connections and pot
Forward speed only Reverse speed only	Faulty forward/reverse switch	Replace switch
Poor scrubbing performance	Debris caught in scrub brushes	Remove debris
	Low scrub brush down pressure	Check brush wear
	Low battery charge	Charge batteries
Little or no solution flow to the floor	Solution tank empty	Fill solution tank
	Solution pump turned off	Turn on pump
	Solution strainer plugged	Clean solution strainer
	Solution system plumbing obstructed	Clear obstruction from plumbing
	Pump obstructed	Clean or replace pump
	Solution solenoid valve obstructed or stuck	Clean or replace valve
	Jet(s) obstructed	Clean or replace jet(s)
	Faulty pump circuit or pump	Check wiring, connections, and pump.
	Faulty solenoid	Check solenoid valve
Brush motors do not run, or run slowly	Circuit breaker(s) tripped	"Reset circuit breaker(s) and check brush pressure."
	Low battery charge	Charge battery
	Fault brush circuit or motor	Check wires, connections and motor
	Worn brush motor brushes	Replace brushes, check commutator
Scrub deck will not go down/up	Actuator circuit breaker tripped	Reset breaker
	Faulty actuator circuit or actuator	Check wires, connections and actuator

Suggested Spare Parts

