



**MODELS 797SS, 797SS-208,
897SS, 897SS-208**

**OPERATING INSTRUCTIONS
AND PARTS MANUAL**

Read instructions carefully before attempting to assemble, install, operate or service this pressure washer. Failure to comply with instructions could result in personal injury and/or property damage!



MODEL:	
SERIAL NUMBER:	
DATE PURCHASED:	
FOR SALES AND SERVICE, PLEASE CONTACT:	
Scan or Click to View The Hotsy Safety Video	
	

797SS

- Flow Rate At Pump Head: 3.5 gpm/210 gph
- Pressure At Pump Head: 2000 PSI
- Burner Type: Fuel Oil Fired, 290,000 BTU/Hr.
- Burner Fuel Pressure: 190 PSI Max.
- Machine Voltage: 230Vac/60Hz/1Ph
- Total Machine Amperage: 24 Amps
- Machine Weight: 460 Lbs.
- Shipping Weight: 510 Lbs.
- Exhaust Stack Size: 8"
- Machine Dimensions:
Length = 50", Width = 29", Height = 42.5"

797SS-208

- Flow Rate At Pump Head: 3.5 gpm/210 gph
- Pressure At Pump Head: 2000 PSI
- Burner Type: Fuel Oil Fired, 290,000 BTU/Hr.
- Burner Fuel Pressure: 190 PSI Max.
- Machine Voltage: 208Vac/60Hz/1Ph
- Total Machine Amperage: 27 Amps
- Machine Weight: 463 Lbs.
- Shipping Weight: 513 Lbs.
- Exhaust Stack Size: 8"
- Machine Dimensions:
Length = 50", Width = 29", Height = 42.5"

897SS

- Flow Rate At Pump Head: 3.2 gpm/192 gph
- Pressure At Pump Head: 3000 PSI
- Burner Type: Fuel Oil Fired, 255,000 BTU/Hr.
- Burner Fuel Pressure: 190 PSI Max.
- Machine Voltage: 230Vac/60Hz/1Ph
- Total Machine Amperage: 28 Amps
- Machine Weight: 467 Lbs.
- Shipping Weight: 517 Lbs.
- Exhaust Stack Size: 8"
- Machine Dimensions:
Length = 50", Width = 29", Height = 42.5"

897SS-208

- Flow Rate At Pump Head: 3.2 gpm/192 gph
- Pressure At Pump Head: 3000 PSI
- Burner Type: Fuel Oil Fired, 255,000 BTU/Hr.
- Burner Fuel Pressure: 190 PSI Max.
- Machine Voltage: 208Vac/60Hz/1Ph
- Total Machine Amperage: 29 Amps
- Machine Weight: 470 Lbs.
- Shipping Weight: 520 Lbs.
- Exhaust Stack Size: 8"
- Machine Dimensions:
Length = 50", Width = 29", Height = 42.5"

CONTENTS

Introduction & Important Safety Information	5
Component Identification.....	9
Assembly Instructions.....	10
Installation Instructions	11
Operation Instructions	12
Maintenance	14
Storage	14
Troubleshooting	16
Wiring Diagram 700 Series.....	18
Wiring Diagram 700 Series.....	19

Model Number _____

Serial Number _____

Date of Purchase _____

The model and serial numbers will be found on a decal attached to the pressure washer. You should record both serial number and date of purchase and keep in a safe place for future reference.

INTRODUCTION & IMPORTANT SAFETY INFORMATION

Thank you for purchasing this Pressure Washer.

We reserve the right to make changes at any time without incurring any obligation.

Owner/User Responsibility:

The owner and/or user must have an understanding of the manufacturer's operating instructions and warnings before using this pressure washer. Warning information should be emphasized and understood. If the operator is not fluent in English, the manufacturer's instructions and warnings shall be read to and discussed with the operator in the operator's native language by the purchaser/owner, making sure that the operator comprehends its contents.

Owner and/or user must study and maintain for future reference the manufacturers' instructions.

The operator must know how to stop the machine quickly and understand the operation of all controls. Never permit anyone to operate the engine without proper instructions.

SAVE THESE INSTRUCTIONS

This manual should be considered a permanent part of the machine and should remain with it if machine is resold.

When ordering parts, please specify model and serial number. Use only identical replacement parts.

This machine is to be used only by trained operators.

4. All installations must comply with local codes. Contact your electrician, plumber, utility company or the selling distributor for specific details. If your machine is rated 250 volts or less, single phase, will be provided with a ground fault circuit interrupter (GFCI). If rated more than 250 volts, or more than single phase, this product should only be connected to a power supply receptacle protected by a GFCI.

DANGER: Improper connection of the equipment-grounding conductor can result in a risk of electrocution. Check with a qualified electrician or service personnel if you are in doubt as to whether the outlet is properly grounded. Do not modify the plug provided with the product - if it will not fit the outlet, have a proper outlet installed by a qualified electrician. Do not use any type of adaptor with this product.

DANGER: Une mauvaise connexion du conducteur de terre de l'équipement peut entraîner un risque d'électrocution. Vérifier auprès d'un électricien qualifié ou du personnel d'entretien si vous avez des doutes quant à savoir si la sortie est correctement mise à la masse. Ne pas modifier la fiche fournie avec le produit si elle n'entre pas dans la sortie, faire installer une sortie appropriée par un électricien qualifié. Ne jamais utiliser un adaptateur avec ce produit.

PELIGRO: La conexión incorrecta del conductor de puesta a tierra del equipo puede dar como resultado el riesgo de electrocución. Si tiene alguna duda acerca de la puesta a tierra adecuada del tomacorriente, consulte con un electricista o técnico calificado. No modifique el enchufe provisto con el producto - si no encaja en el tomacorriente, solicite a un electricista calificado que le instale un tomacorriente adecuado. No use ningún tipo de adaptador con este producto.

WARNING: Must be plugged into properly wired three hole grounded outlet that accommodates plug on power cord. Failure to comply could result in electrical shock.

AVERTISSEMENT: Doit être raccordé dans une sortie à trois trous mise à la masse et correctement câblée qui peut accueillir une fiche sur un cordon d'alimentation Le non-respect de cette consigne pourrait causer un choc électrique.

ADVERTENCIA: Se debe enchufar en un tomacorriente con puesta a tierra, de tres agujeros, correctamente conectado, que se adapte al enchufe del cable de alimentación. Si no se cumple este requisito se puede producir una descarga eléctrica.

IMPORTANT SAFETY INFORMATION



WARNING: To reduce the risk of injury, read operating instructions carefully before using.

AVERTISSEMENT: Pour réduire le risque de blessures, lire attentivement les instructions de fonctionnement avant l'utilisation.

ADVERTENCIA: Para reducir el riesgo de lesiones, lea cuidadosamente las instrucciones de operación antes de usar.

1. Read the owner's manual thoroughly. Failure to follow instructions could cause malfunction of the machine and result in death, serious bodily injury and/or property damage.

2. Know how to stop the machine and bleed pressure quickly. Be thoroughly familiar with the controls.

3. Stay alert — watch what you are doing.

IMPORTANT SAFETY INFORMATION



WARNING: Keep wand, hose, and water spray away from electric wiring or fatal electric shock may result.

AVERTISSEMENT: Garder la lance, le boyau et le jet d'eau à l'écart de tout câblage électrique ou des chocs électriques mortels pourraient survenir.

ADVERTENCIA: Mantenga la varilla, la manguera y el rocío de agua lejos del cableado eléctrico, ya que podrían producirse descargas eléctricas fatales.

- To protect the operator from electrical shock, the machine must be electrically grounded. It is the responsibility of the owner to connect this machine to a UL grounded receptacle of proper voltage and amperage ratings. Do not spray water on or near electrical components. Do not touch machine with wet hands or while standing in water. Always disconnect power before servicing.

WARNING: Flammable liquids can create fumes which can ignite, causing property damage or severe injury.

AVERTISSEMENT: Des liquides inflammables peuvent produire des vapeurs qui peuvent s'enflammer, causant ainsi des dommages à la propriété ou des blessures graves.

ADVERTENCIA: Los líquidos inflamables pueden generar vapores que pueden encenderse y causar daños a la propiedad o lesiones graves.



WARNING: Risk of explosion — Operate only where open flame or torch is permitted.

AVERTISSEMENT: Risque d'explosion — Utiliser uniquement dans des endroits où l'utilisation d'une flamme nue ou d'une torche est permise.

ADVERTENCIA: Riesgo de explosión. Opere sólo donde se permitan llamas abiertas o soplete.

- In oil burning models, use only kerosene, No. 1 home heating fuel, or diesel. If diesel is used, add a soot remover to every tankful.



WARNING: Risk of fire — Do not add fuel when the product is operating or still hot.

AVERTISSEMENT: Risque d'incendie — Ne pas ajouter de carburant pendant que la machine fonctionne ou est encore chaude.

ADVERTENCIA: Riesgo de incendio -- No agregue combustible cuando el producto está en funcionamiento o aún está caliente.

WARNING: Do not use gasoline crankcase draining or oil containing gasoline, solvents or alcohol. Doing so will result in fire and/or explosion.

AVERTISSEMENT: Ne pas utiliser d'essence, de drainage du carter de moteur ou d'essence contenant de l'huile, de solvants ou de l'alcool. Agir de la sorte risquerait de créer un incendie et/ou une explosion.

ADVERTENCIA: No utilice el drenaje del cárter de gasolina ni aceite que contenga gasolina, solventes o alcohol. Hacerlo resultará en incendio y/o explosión.

- Oil burning appliances shall be installed only in locations where combustible dusts and flammable gases or vapors are not present. Do not store or use gasoline near this machine.
- Do not allow acids, caustic or abrasive fluids to pass through the pump.
- Never run pump dry or leave spray gun closed longer than 1-2 minutes.
- Keep operating area clear of all persons.



WARNING: High pressure spray can cause paint chips or other particles to become airborne and fly at high speeds. To avoid personal injury, eye, hand and foot safety devices must be worn.

AVERTISSEMENT: Un jet haute pression peut écailler

la peinture ou provoquer l'émission d'autres particules dans l'air et leur projection à hautes vitesses. Pour éviter les lésions corporelles, une protection des yeux, du visage, des mains et des pieds doit être portée lors de l'utilisation de cet équipement.

ADVERTENCIA: El rociado a alta presión puede hacer que las partículas de pintura u otras

IMPORTANT SAFETY INFORMATION

partículas se transporten por aire y vuelen a altas velocidades. Para evitar lesiones personales, se deben usar dispositivos de seguridad para ojos, manos y pies.

11. Eye, hand, and foot protection must be worn when using this equipment. (Safety glasses do not provide full protection.)



WARNING: This machine exceeds 85 db appropriate ear protection must be worn.

AVERTISSEMENT : Cette machine excède 85 dB et une protection de l'ouïe appropriée doit être portée.

ADVERTENCIA: Esta máquina supera los 85 dB, se debe usar protección auditiva adecuada.



WARNING: Hot discharge fluid. Do not touch or direct discharge stream at persons.

AVERTISSEMENT: Liquide de décharge chaud. Ne pas toucher ou décharger directement le jet vers des personnes.

ADVERTENCIA: Fluido de descarga caliente. No toque ni dirija el flujo de descarga a las personas.



WARNING: This machine produces hot water and must have insulated components attached to protect the operator.

AVERTISSEMENT: Cette machine produit de l'eau chaude et doit comporter des composants isolés attachés pour protéger l'opérateur.

ADVERTENCIA: Esta maquina produce agua caliente y se deben tener componentes aislados para proteger al operador.

WARNING: Risk of injury. Hot surfaces can cause burns. Use only designated gripping areas of spray gun and wand. Do not place hands or feet on non-insulated areas of the pressure washer.

AVERTISSEMENT: Risque de blessures. Les surfaces chaudes peuvent causer des brûlures. Utiliser uniquement les zones de prise désignées du pistolet pulvérisateur et de la lance. Ne pas placer les mains ou les pieds sur des endroits non isolés de la laveuse à pression.

ADVERTENCIA: Riesgo de lesiones. Las superficies calientes pueden causar quemaduras. Use sólo las áreas de agarre designadas de la pistola rociadora y la varilla. No coloque las manos o los pies en áreas sin aislamiento de la lavadora a presión.

12. To reduce the risk of injury, close supervision is necessary when a machine is used near children. Do not allow children to operate the pressure washer. This machine must be attended during operation.



WARNING: Grip cleaning wand securely with both hands before starting. Failure to do this could result in injury from a whipping wand.

AVERTISSEMENT: Agripper la lance de nettoyage avec les deux mains avant de commencer. Le non- respect de cette consigne

pourrait mener à des blessures causées par le mouvement violent de la lance.

ADVERTENCIA: Sujete la lanza de limpieza firmemente con ambas manos antes de comenzar. De lo contrario, podría sufrir lesiones a partir de un latigazo de la lanza.

13. Never make adjustments on machine while in operation.

14. Be certain all quick coupler fittings are secured before using pressure washer.



WARNING: High pressure developed by these machines will cause personal injury or equipment damage. Keep clear of nozzle. Use caution when operating. Do not direct discharge stream at people or animals, or severe injury or death will result.

AVERTISSEMENT: La haute pression générée par ces machines causera des lésions corporelles ou des dommages à l'équipement. Se tenir à l'écart de la buse. Faire preuve de prudence lors de l'utilisation. Ne pas décharger directement le jet vers des gens, cela pourrait causer des blessures graves voire la mort.

ADVERTENCIA: La alta presión desarrollada por estas máquinas causará lesiones personales o daños al equipo. Manténgase alejado de la boquilla. Tenga cuidado al operar. No dirija el flujo de descarga a las personas, ya que se producirán lesiones graves o la muerte.

IMPORTANT SAFETY INFORMATION



WARNING: Protect machine from freezing.

AVERTISSEMENT: Protéger la machine contre le gel.

ADVERTENCIA: Proteja la máquina contra congelamiento.

15. To keep machine in best operating conditions, it is important you protect machine from

freezing. Failure to protect machine from freezing could cause malfunction of the machine and result in death, serious bodily injury, and/or property damage. Follow storage instructions specified in this manual.

16. Inlet water must be clean fresh water and no hotter than 90°F.



WARNING: Risk of asphyxiation. Use this product only in a well ventilated area.

AVERTISSEMENT: Risque d'asphyxie. Utiliser ce produit uniquement dans un endroit bien ventilé.

ADVERTENCIA: Riesgo de asfixia. Use este producto sólo en un área bien ventilada.

17. Avoid installing machines in small areas or near exhaust fans. Adequate oxygen is needed for combustion or dangerous carbon monoxide will result.

18. Manufacturer will not be liable for any changes made to our standard machines or any components not purchased from us.

19. The best insurance against an accident is precaution and knowledge of the machine.



WARNING: Be extremely careful when using a ladder, scaffolding or any other relatively unstable location. The cleaning area should have adequate slopes and drainage to reduce the possibility of a fall due to slippery surfaces.

AVERTISSEMENT: Faire preuve d'une extrême prudence au moment d'utiliser une échelle, des échafaudages ou toute autre surface relativement instable. La zone de nettoyage doit avoir une pente et un drainage adéquats pour réduire la possibilité d'une chute due à une surface glissante.

ADVERTENCIA: Tenga mucho cuidado al usar una escalera, andamios o cualquier otra ubicación relativamente inestable. El área de limpieza debe tener pendientes y drenaje adecuados para reducir

la posibilidad de una caída debido a las superficies resbaladizas.

20. Do not overreach or stand on unstable support. Keep good footing and balance at all times.

21. Do not operate this machine when fatigued or under the influence of alcohol, prescription medications or drugs.



WARNING: Do not spray machine or any people, animals or electrical parts.

AVERTISSEMENT: Ne pas vaporiser sur la machine ou les gens, les animaux ou les pièces électriques

ADVERTENCIA: No rocíe la máquina ni a las personas, animales o partes eléctricas.

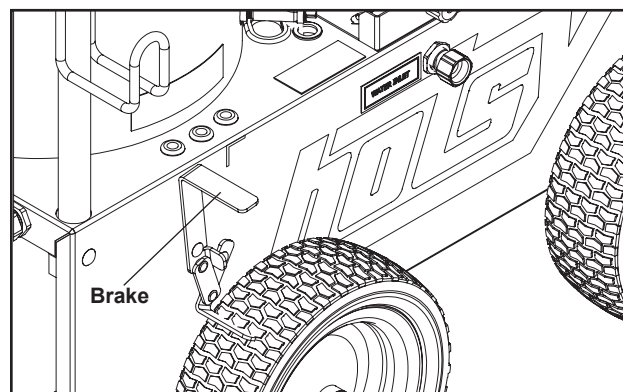

WARNING: To prevent damage or injury - Keep brake engaged during machine operation and storage.

AVERTISSEMENT: Pour prévenir les dommages ou les blessures - Garder le frein appliqué pendant le fonctionnement et l'entreposage de la machine.

ADVERTENCIA: Para evitar daños o lesiones. Mantenga el freno activado durante la máquina operación y almacenaje.



Follow the maintenance instructions specified in the manual.

COMPONENT IDENTIFICATION

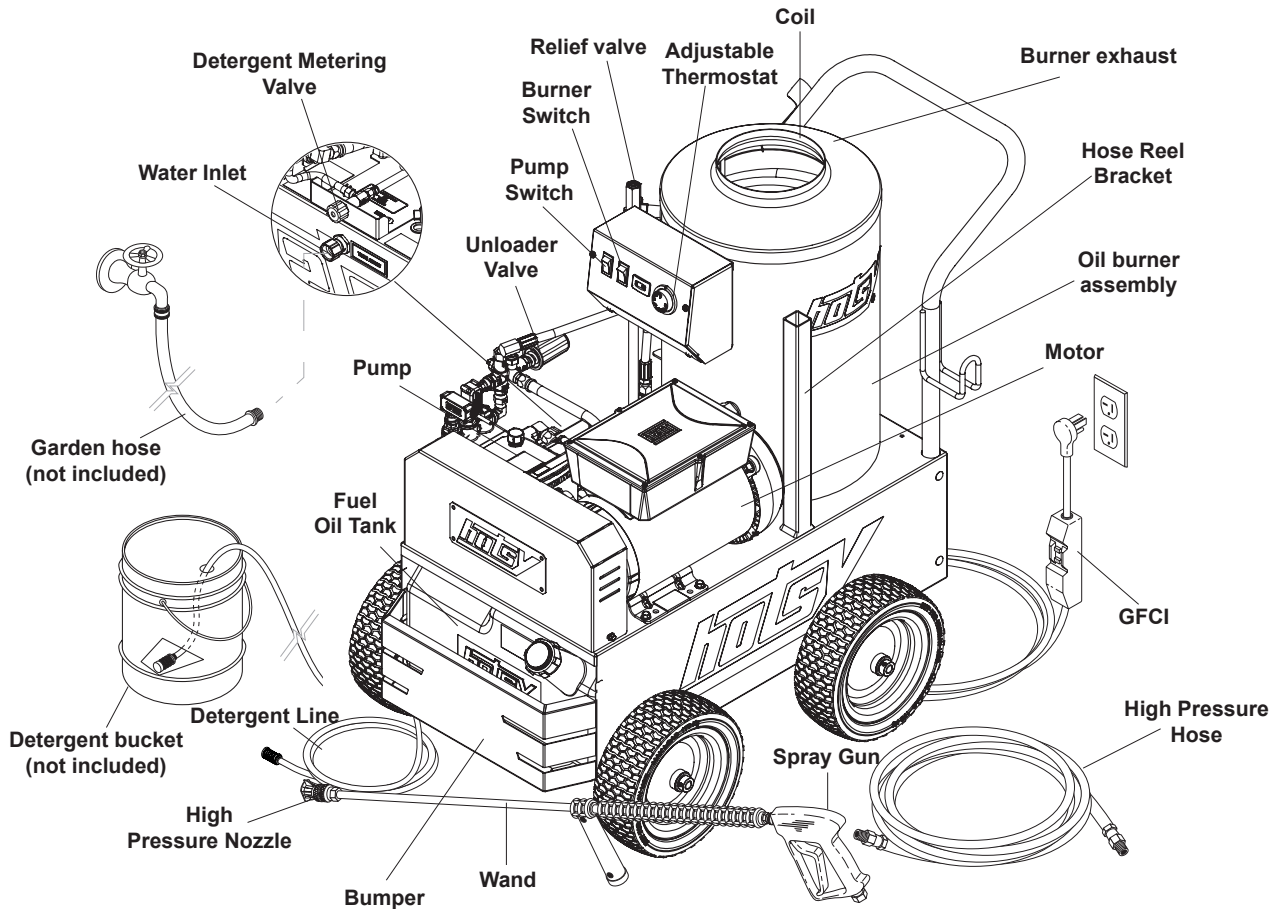

Pump — Delivers a specific gpm to the high pressure nozzle which develops pressure.

Spray Gun — Controls the application of water and detergent onto cleaning surface with trigger device. Includes safety latch.

Detergent Injector — Allows you to siphon and mix detergents.

Wand — Must be connected to the spray gun.

High Pressure Hose — Connect one end to water pump high pressure discharge nipple and the other end to spray gun.

Unloader Valve — Safety device which, when the spray gun closes, prevents over pressurization (Not Shown.)

Relief valve — Secondary pressure release in the unlikely event the unloader valve fails.

Pressure Nozzle — Inserted into wand quick coupler to develop pressure

Adjustable Thermostat — Prevents water temperature from exceeding high temperatures. Is not used to maintain constant temperature setting.

Oil Burner Assembly — Converts fuel oil from a liquid state into a combustible mixture.

Hose Reel Bracket — Mounts optional hose reel.

Note: If trigger on spray gun is released for more than 2 minutes, water will leak from the pump protector. Warm water will discharge from pump protector onto floor. This system prevents internal pump damage.

ASSEMBLY INSTRUCTIONS

Unpacking

Unpack carefully. Wear safety glasses or goggles while unpacking, assembling or operating pressure washer. If there are missing components or hidden damage immediately contact distributor or carrier concerning discrepancies.

1. Cut strapping band from pressure washer and pallet.
2. Remove pressure washer from pallet.

Parts Included

- Pressure Washer
- Pressure Hose
- Trigger Gun Assembly
- Wand Assembly
- Handle

Tools Required

- 10" Adjustable Wrench (2 ea.)
- Teflon Tape

Pressure Hose, Trigger Gun and Wand

1. Use teflon tape or thread sealant on plumbing connections to prevent leakage.
2. Install pressure hose on machine as shown in Figure 1.

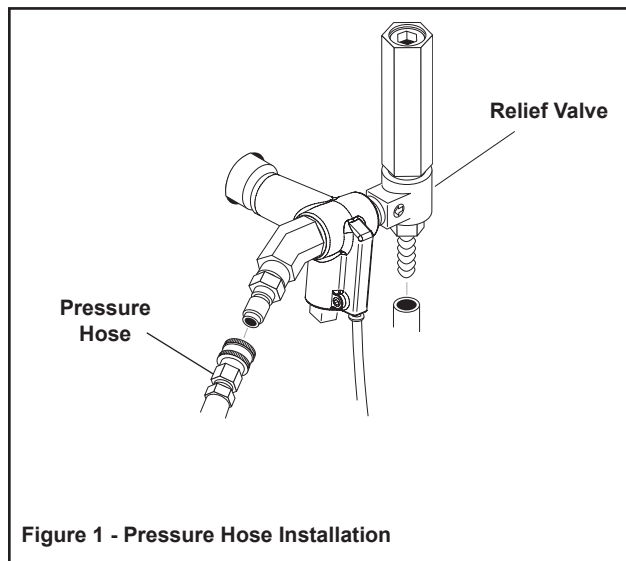

3. Attach the wand assembly to the pressure hose/trigger gun assembly as shown in Figure 2.

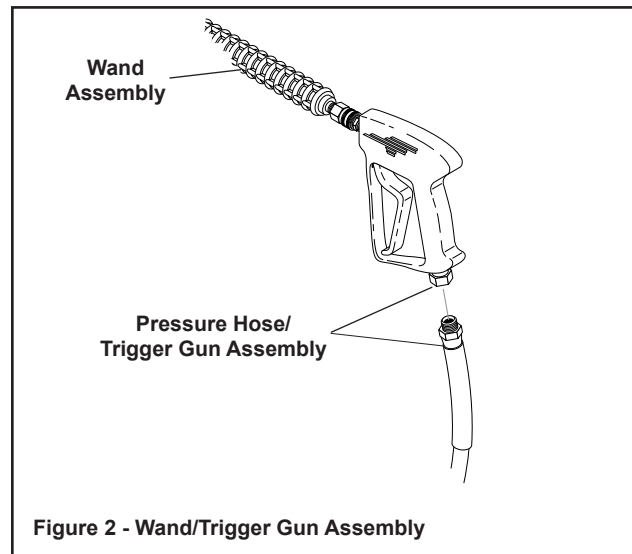

Handle

1. Remove plastic tubing from ends of handle.
2. Insert the handle through the holes in the chassis as shown in Figure 3. Use the bolts, washers and nuts from envelope to secure the handle to the chassis.

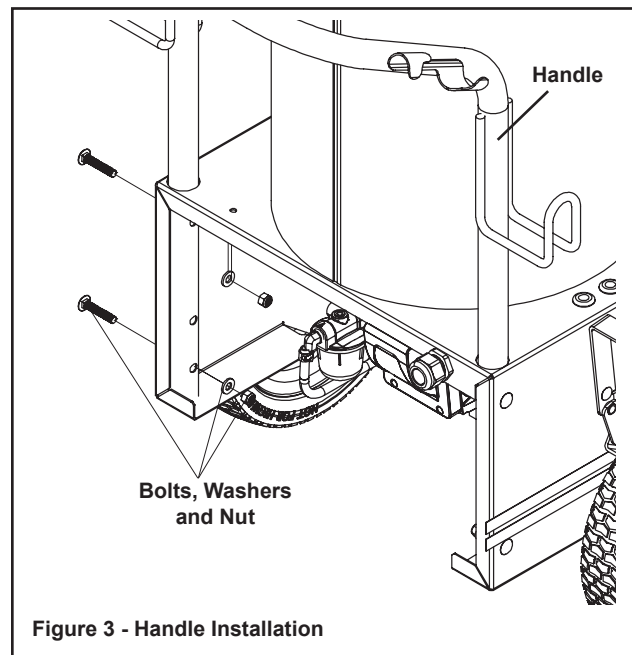

INSTALLATION INSTRUCTIONS

Getting Started

IMPORTANT: Proper initial installation of equipment will assure more satisfactory performance, longer service life and lower maintenance cost.

WARNING: If connection is made to a potable water system, the system shall be protected against backflow.

AVERTISSEMENT: Si une connexion est établie avec un réseau d'eau potable, le réseau doit être protégé contre le retour d'eau.

ADVERTENCIA: Si se realiza una conexión a un sistema de agua potable, el sistema debe estar protegido contra el reflujó.

The pressure washer should be run on a level surface where it is not readily influenced by outside sources such as strong winds, freezing temperatures, rain, etc. The pressure washer should be located to assure easy access for filling of fluids, adjustments and maintenance. Normal precautions should be taken by the operator to prevent moisture from reaching the pressure washer. It is recommended that a partition be made between the wash area and the pressure washer to prevent direct spray from the wand coming in contact with the pressure washer. Moisture reaching the equipment will reduce the pressure washer's life. All installations should comply with the local codes covering such installations.

Venting

CAUTION: All venting must be in accordance with applicable federal and state laws, and local ordinances. Consult local heating contractors.

ATTENTION: Toute la ventilation doit être conforme aux lois fédérales et de l'État ou de la province, et aux réglementations locales applicables. Consulter des entrepreneurs en systèmes de chauffage locaux.

PRECAUCIÓN: Toda la ventilación debe ser de acuerdo con las leyes federales y estatales aplicables y las ordenanzas locales. Consulte a contratistas locales de calefacción.

If the pressure washer is to be used in an enclosed area, a flue must be installed to vent burner exhaust to the outside atmosphere. Exhaust gases should not be vented into a wall, a ceiling, or a concealed space of a building. Be sure the flue is the same size as the burner exhaust vent on the pressure washer. See Component Identification for location. Poor draft will cause the pressure washer to soot and not operate properly. When selecting the location for installation, beware of poorly ventilated locations or areas where exhaust

fans may cause an insufficient supply of oxygen. Proper combustion can only be obtained when there is a sufficient supply of oxygen available for the amount of fuel being burned. If it is necessary to install the machine in a poorly ventilated area, outside fresh air may have to be piped to the burner and a fan installed to bring sufficient air into the machine. Locate the pressure washer so that the flue will be as straight as possible and protrude through the roof at a proper height and location to provide adequate draft. This oil fired pressure washer must have a draft regulator installed in the flue (available from most heating contractors). A draft regulator will permit proper upward flow of exhaust flue gases.

NOTE: This product is labeled of outdoor use only and should be operated outdoors. It is not recommended to operate indoors. If under certain conditions that make it impossible to operate outdoors you can operate indoor using a hood vent or venting. Venting can cause restriction of air flow through the combustion chamber causing excessive soot. Use a larger vent size than the exhaust stack to prevent restriction and contact the local servicing dealer to adjust the air mixture after installation of vent.

Burner Air Adjustment

The oil burner on this machine is preset for operation at altitudes below 500 feet. If operated at higher altitudes, it may be necessary to adjust the air band for a #1 or #2 smoke spot on the Bacharach scale.

To adjust, start machine and turn burner ON. Loosen two locking screws found on the air band and close air band until black smoke appears from burner exhaust vent. Note air band position. Next, slowly open the air band until white smoke just starts to appear. Turn air band halfway back to the previously noted position. Tighten locking screws.

For higher altitudes, the air band opening may need to be increased; for lower altitude, the air band may need to be decreased.

For higher humidity, the air band opening may need to be increased; for lower relative humidity, the air band may need to be decreased.

For higher ambient temperatures the air band opening may need to be increased; for lower ambient temperatures, the air band opening may need to be decreased.

Adjust to your operating location's environment as needed for best smoke spot and performance compliant with local, state, and federal regulations.

OPERATION INSTRUCTIONS

Before Starting

WARNING: Check hoses, guns, fittings, and fuel connections daily for signs of wear, cracks and looseness, and replace as required.

AVERTISSEMENT: Vérifier quotidiennement les tuyaux, les pistolets à gâchette et les connexions de carburant pour la présence de traces d'usure, de fissures et de desserrement, puis remplacer au besoin.

ADVERTENCIA: Compruebe las mangueras, pistolas de disparo, puntos de sujeción y conexiones de combustible diariamente para detectar signos de desgaste, grietas y piezas flojas y haga los cambios necesarios

1. Read all manuals provided with this pressure washer. Become familiar with location and function of all operating and safety controls.
2. Connect water supply hose to the standard garden hose connector. The water faucet and supply hose must be capable of providing 4.0 gpm.
3. Fill fuel tank. Use kerosene, #1 grade home heating oil, #1 or #2 diesel fuel. DO NOT USE GASOLINE, CRANKCASE OIL DRAININGS OR WASTE OIL.
4. Check pump oil level.
5. If detergents are to be used, only use detergents intended for pressure washers. Follow instructions on the detergent container.

Electrical Connections

WARNING: Make sure all switches and controls are in the OFF position prior to plugging in.

AVERTISSEMENT : S'assurer que tous les commutateurs et toutes les commandes se trouvent en position OFF (arrêt) avant de brancher l'appareil.

ADVERTENCIA: Asegúrese de que todos los interruptores y controles estén en posición OFF (apagado) antes de enchufar la máquina.

CAUTION: This pressure washer is equipped with a UL approved ground fault circuit interrupter (GFCI) power cord. Use UL grounded type receptacles of proper voltage and amperage ratings. Where a properly grounded receptacle is not available, it is the personal responsibility of the owner to have one installed. Always disconnect power before servicing your pressure washer.

ATTENTION: Cette laveuse à pression est équipée d'un cordon d'alimentation de disjoncteur différentiel de fuite à la terre (DDFT) approuvé par l'UL. Utiliser des prises de type UL mises à la masse de tension et d'intensité de courant nominales appropriées. Lorsqu'une prise correctement mise à la masse n'est pas disponible, il incombe

au propriétaire d'en faire installer une. Toujours débrancher l'alimentation avant d'effectuer des opérations d'entretien sur la laveuse à pression.

PRECAUCIÓN: Esta hidrolavadora está equipada con un cable de alimentación para interruptor de protección de fallas de tierra (GFCI) aprobado con certificación UL. Use receptáculos con puesta a tierra UL de voltaje y amperaje adecuados. Si no hay un receptáculo con puesta a tierra adecuado, es responsabilidad del personal del propietario hacer que se instale uno. Desconecte siempre la alimentación eléctrica antes de realizar el mantenimiento de su hidrolavadora.

Connect electrical cord and test the GFCI using the reset and test procedures provided on the GFCI device. The GFCI must be reset and tested with every use. Do not use machine if the GFCI device fails test.

WARNING: Use copper conductors only.

AVERTISSEMENT: Utiliser des conducteurs en cuivre seulement.

ADVERTENCIA: Utilice sólo conductores de cobre.

Nozzle Installation

IMPORTANT: Before installing nozzle on initial start-up, turn on the water supply, and allow water to run from the end of the wand until clear to prevent the nozzle from clogging.

IMPORTANT: If the pressure washer has not been used for an extended period of time, remove the nozzle from the end of the wand and turn on water supply. Allow water to run from the end of the wand until clear.

CAUTION: Never replace nozzles without engaging the safety latch on the spray gun trigger.

ATTENTION: Ne jamais remplacer les buses sans d'abord mettre le dispositif de sécurité sur la détente du pistolet pulvérisateur.

ADVERTENCIA: Nunca reemplace las boquillas sin asegurar el candado de seguridad en la pistola pulverizadora

1. Install the proper pressure nozzle for your cleaning needs on the end of the wand. Refer to Figure 4.

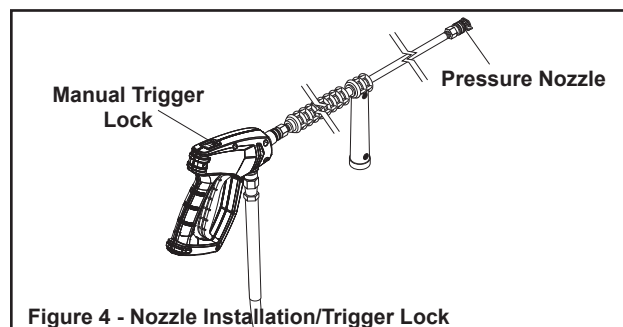

Figure 4 - Nozzle Installation/Trigger Lock

OPERATION INSTRUCTIONS

IMPORTANT: The trigger gun provided with this pressure washer is equipped with a manual trigger lock to prevent accidental operation of the trigger gun; refer to Figure 5. The trigger lock should be used whenever the trigger gun is not in use.

To Start

IMPORTANT: The water must be turned on before starting. Running the pump dry will cause damage to pump seals and void warranty.

IMPORTANT: DO NOT allow the machine to run in bypass for more than 10 minutes at any one time or damage to pump may occur.

WARNING: Pressure washers produce a kickback. To prevent personal injuries due to falls use auxiliary safety equipment.

AVERTISSEMENT: Les laveuses à pression produisent un rebond. Pour prévenir les lésions corporelles dues aux chutes, utiliser un équipement de sécurité auxiliaire.

ADVERTENCIA: Las hidrolavadoras generan tensión de retroceso. Para evitar lesiones personales debido a caídas, use el equipo de seguridad auxiliar.

1. Turn water ON.
2. Hold gun firmly, squeeze trigger of trigger gun and turn pump switch ON. Allow air to purge from system.
3. If HOT water is desired, turn burner switch ON. Adjust thermostat to desired temperature. The burner will fire immediately with a small puff of smoke. If smoke continues refer to the Troubleshooting Guide in this manual. When the trigger gun is closed the burner will turn off.

To Stop

1. If detergents were used, draw clear water through the detergent line to purge detergent.
2. If burner was used, turn off burner switch and allow pump to run cold water through coil.
3. Turn pump switch OFF.
4. Turn OFF water supply.
5. Squeeze trigger gun open to relieve system pressure.

NOTE: If the machine is unplugged from receptacle, you must reset the GFCI power cord when machine is plugged in. Always test GFCI before each use. See instructions in the Electrical Connections section of this manual.

GENERAL CLEANING TECHNIQUES & STORAGE

CLEANING TECHNIQUES

Pre-rinse cleaning surface with fresh water. Place detergent suction tube directly into cleaning solution and apply to surface at low pressure (for best results, limit your work area to sections approximately 6 feet square and always apply detergent from bottom to top). Allow detergent to remain on surface 1-3 minutes. Do not allow detergent to dry on surface. If surface appears to be drying, simply wet down surface with fresh water. If needed, use brush to remove stubborn dirt. Rinse at high pressure from top to bottom in an even sweeping motion keeping the spray nozzle approximately 1 foot from cleaning surface. Use overlapping strokes as you clean and rinse any surface. For best surface cleaning action spray at a slight angle.

Recommendations:

- Before cleaning any surface, an inconspicuous area should be cleaned to test spray pattern and distance for maximum cleaning results.
- If painted surfaces are peeling or chipping, use extreme caution as pressure washer may remove the loose paint from the surface.
- Keep the spray nozzle a safe distance from the surface you plan to clean. High pressure wash a small area, then check the surface for damage. If no damage is found, continue to pressure washing.

CAUTION - Never use:

- Bleach, chlorine products and other corrosive chemicals
- Liquids containing solvents (i.e., paint thinners, gasoline, oils)
- Tri-sodium phosphate products
- Ammonia products
- Acid-based products

ATTENTION: Ne jamais utiliser:

- Eau de Javel, produits à base de chlore et autres produits chimiques corrosifs
- Liquides contenant des solvants (c.-à-d. diluant à peinture, essence, huiles, etc.)
- Produits à base de tripolyphosphate de sodium
- Ammoniac ou produits à base d'acide

PRECAUCIÓN: Nunca utilice:

- Cloro, productos a base de cloro u otros productos corrosivos
- Líquidos que contengan solventes (i.e., diluyentes de pintura, gasolina, aceites)
- Productos de fosfato trisódico
- Productos con amoníaco
- Ácidos

These chemicals will harm the machine and will damage the surface being cleaned.

GENERAL CLEANING TECHNIQUES & STORAGE

RINSING

It will take a few seconds for the detergent to clear. Apply safety latch to spray gun. Select and install desired high pressure nozzle. NOTE: You can also stop detergent from flowing by removing detergent siphon tube from bottle.

STORAGE

Protect from freezing by storing in a heated area, or by flushing the system with antifreeze (use an automotive engine antifreeze or windshield washer solvent to antifreeze). To flush the system with antifreeze, attach a short length of hose to the garden hose connector

located on the pump. Place the other end of the hose into a container of antifreeze. Start machine and allow to run until antifreeze flows from the end of the wand. Squeeze and release the trigger of the trigger gun several times to antifreeze the unloader system. Also draw antifreeze through the detergent inlet line to antifreeze the detergent system. For added protection after anti-freezing, disconnect the pressure hose from machine and remove the coil drain plug (refer to Component Identification for location). After coil has drained, replace pressure hose and coil drain plug. If the pressure washer is not to be used for an extended length of time, it is recommended that the system be flushed with antifreeze for rust protection.

MAINTENANCE

WARNING: Unauthorized machine modification or use of non-approved replacement parts may cause personal injury and/or property damage and will void the manufacturer warranty.

AVERTISSEMENT : Une modification non autorisée de la machine ou l'utilisation de pièces de rechange non approuvées peut causer des lésions corporelles et/ou des dommages à la propriété, et annulera la garantie du fabricant.

ADVERTENCIA: La modificación no autorizada de la máquina o el uso de piezas de repuesto no aprobadas puede causar lesiones personales y/o daños materiales y anula la garantía del fabricante.

Pump

Lubrication: To lubricate pump, use 30W non-detergent oil for pump crankcase. Crankcase must be filled to center of sight glass window found on the side of the pump; refer to Figure 5. During the break-in period, make sure the oil is changed after the first 25 hours of operation. After that, replace oil every 3 months or 300 hours of operation, whichever comes first.

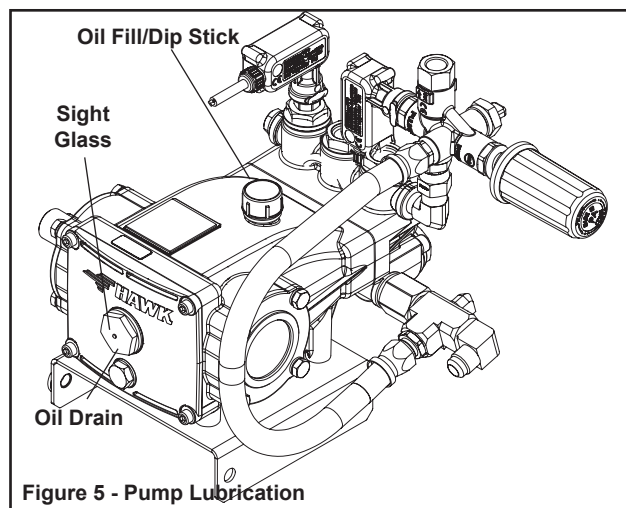

Figure 5 - Pump Lubrication

Proper Pump Care:

- DO NOT pump acids.
- DO NOT allow pump to run dry.
- Winterize if storing in freezing temperatures. Refer to Storage for details.
- Use a water softener on the water system if known to be high in mineral content.
- Use only high quality detergents and follow manufacturer's mix recommendations.
- Flush the system with clear water immediately after using detergent solutions.
- Clean filter screen on detergent inlet line periodically.
- Flush the pressure washer system with antifreeze if storing for an extended period of time, refer to Storage for details.

Pump Motor

On a yearly basis, oil pump motor per instructions on motor nameplate.

Relief Valve

WARNING: The relief valve on this pressure washer has been factory set and sealed and is a field non-adjustable part. Tampering with the factory setting may cause personal injury and/or property damage, and will void the manufacturer warranty. For replacement parts refer to Coil Outlet Assembly.

AVERTISSEMENT : La soupape de sécurité sur cette laveuse à pression a été réglée en usine, puis scellée, et est une pièce non réglable. L'altération du paramètre de l'usine pourrait causer des lésions corporelles et/ou des dommages à la propriété, et annulera la garantie du fabricant.

MAINTENANCE

ADVERTENCIA: *La válvula de seguridad de esta hidrolavadora se ha ajustado y sellado en fábrica y es una pieza no ajustable en el campo. La alteración del ajuste de fábrica puede causar lesiones personales y/o daños materiales y anula la garantía del fabricante.*

If pressure from pump or thermal expansion should exceed safe limits, the relief valve will open, allowing high pressure to be discharged through hose to ground. Caution: Inspect relief valve annually for any obstruction.

Unloader Valve

WARNING: *The unloader valve on this pressure washer has been factory set and sealed and is a field nonadjustable part. Tampering with the factory setting may cause personal injury and/or property damage, and will void the manufacturer warranty. For replacement refer to Pump Assembly.*

AVERTISSEMENT : *La soupape de décharge sur cette laveuse à pression a été réglée en usine, puis scellée, et est une pièce non réglable. L'altération du paramètre de l'usine pourrait causer des lésions corporelles et/ou des dommages à la propriété, et annulera la garantie du fabricant.*

ADVERTENCIA: *La válvula de descarga de esta hidrolavadora se ha ajustado y sellado en fábrica y es una pieza no ajustable en el campo. La alteración del ajuste de fábrica puede causar lesiones personales y/o daños materiales y anula la garantía del fabricante.*

Burner Fuel Filter

Drain any water which has accumulated in fuel filter and clean or replace element as needed. For replacement parts, refer to Burner Assembly.

Heating Coil

Coil Descaling: In hard water areas, scale buildup within the heating coil will occur. Scale deposits will decrease the water temperature rise and may eventually clog the heating coil. Contact your local service center when descaling is needed.

Coil Desooting: Poor grades of fuel oil or inadequate combustion air will cause heavy soot buildup on the outside surface of the heating coil. These deposits will insulate the coil. This will restrict the air flow through the coil, further aggravating the soot buildup. Contact your local service center when desooting is needed.

TROUBLESHOOTING

PROBLEM	POSSIBLE CAUSES	CORRECTIVE ACTION
PUMP MOTOR WILL NOT RUN.	GFCI tripped.	Reset and test GFCI with every use. Follow Instructions under Operation .
	No voltage to machine.	Test power supply and correct.
	Pump motor reset button (thermal overload protector) tripped.	Push reset button on control box. If tripped, check for proper voltage or clogged water nozzle.
	Excessive pressure due to clogged water nozzle.	Clean water nozzle.
NO WATER SPRAYS FROM WATER NOZZLE.	Water nozzle completely clogged.	Clean water nozzle.
	Inlet water screen clogged.	Check screen and clean if necessary.
	Pump sucking air.	Fill the detergent container and check for loose hose clamps or fittings.
LOW PRESSURE FROM WATER NOZZLE.	Inlet water screen clogged.	Check screen and clean if necessary.
	Water nozzle worn or incorrect size.	Replace nozzle with proper size.
	Water supply low.	Correct water supply.
	Pump sucking air.	Fill the detergent container and check for loose hose clamps or fittings.
POOR OR NO DETERGENT FLOW.	Low detergent level.	Fill the detergent container.
	Detergent screen clogged.	Clean if necessary.
	Detergent valve not opening.	Check that handle or knob is not slipping on shaft.
	Water nozzle clogged.	Clean water nozzle.
	Excessive inlet pressure (more than 80 PSI).	Install pressure regulator on the inlet line.
BURNER WILL NOT IGNITE WHEN TRIGGER GUN IS OPEN.	Defective pressure switch.	Replace pressure switch.
	No fuel.	Fill fuel tank with proper fuel.
	Fuel valve closed.	Check that fuel valve on fuel tank is open.
	Thermostat set too low.	Raise thermostat setting.
	Burner motor reset button (thermal overload protector) tripped.	Push reset button on burner motor. If tripped, check for proper voltage.
	Clogged fuel filter.	Clean fuel filter.
BURNER SMOKES OR HAS OBNOXIOUS ODOR.	Air intake adjustment needs to be adjusted.	Readjust air intake per the oil burner section of this manual.
	Improper fuel.	Use proper fuel.

TROUBLESHOOTING

PROBLEM		POSSIBLE CAUSES	CORRECTIVE ACTION
MACHINE SMOKES. A) SMOKES WHILE UNIT IS RUNNING. B) SMOKES AT COLD-START WHEN BURNER IS OFF.	AB	Improper fuel or water in fuel	Drain tank and replace contaminated fuel.
	AB	Improper air adjustment	Readjust air bands on burner assembly.
	AB	Low fuel pressure < 150 PSI	Adjust fuel pump pressure to specifications.
	AB	Weak fuel pump	Check fuel pump pressure. Replace pump if needed.
	AB	Fuel filter partially clogged	Replace as needed.
	AB	Soot build up on coils	Clean coils with soot remover.
	AB	Improper burner nozzle	See combustion assembly breakdown.
	AB	Electrode is misaligned	Realign electrodes to specs.
	B	Fuel pressure is too high for clean burn (Fuel PSI above 150 but less than 200)	Reduce fuel PSI / increase air and band set for cleaner burn without max water heat loss.

IMPORTANT

If the pressure washer demonstrates other symptoms or the corrective actions listed do not correct the problem, contact the local authorized Hotsy Service Center. The Hotsy Service Center can be identified by visiting www.hotsy.com.

When ordering from your dealer, please provide the following:

Model Number: _____

Machine Serial Number: _____

Component Part Number: _____

Description: _____

WIRING DIAGRAM 700 SERIES

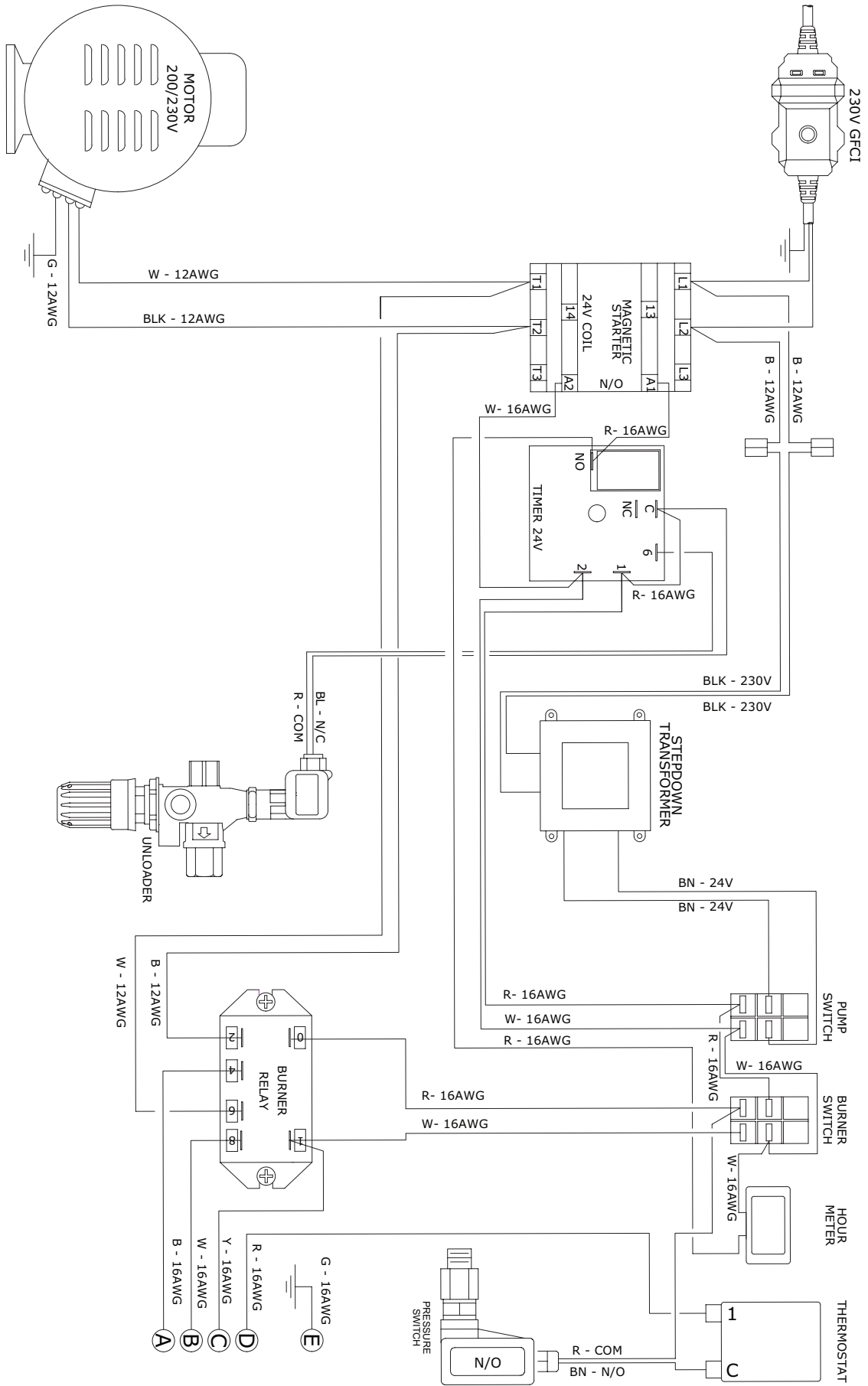

WIRING DIAGRAM 700 SERIES

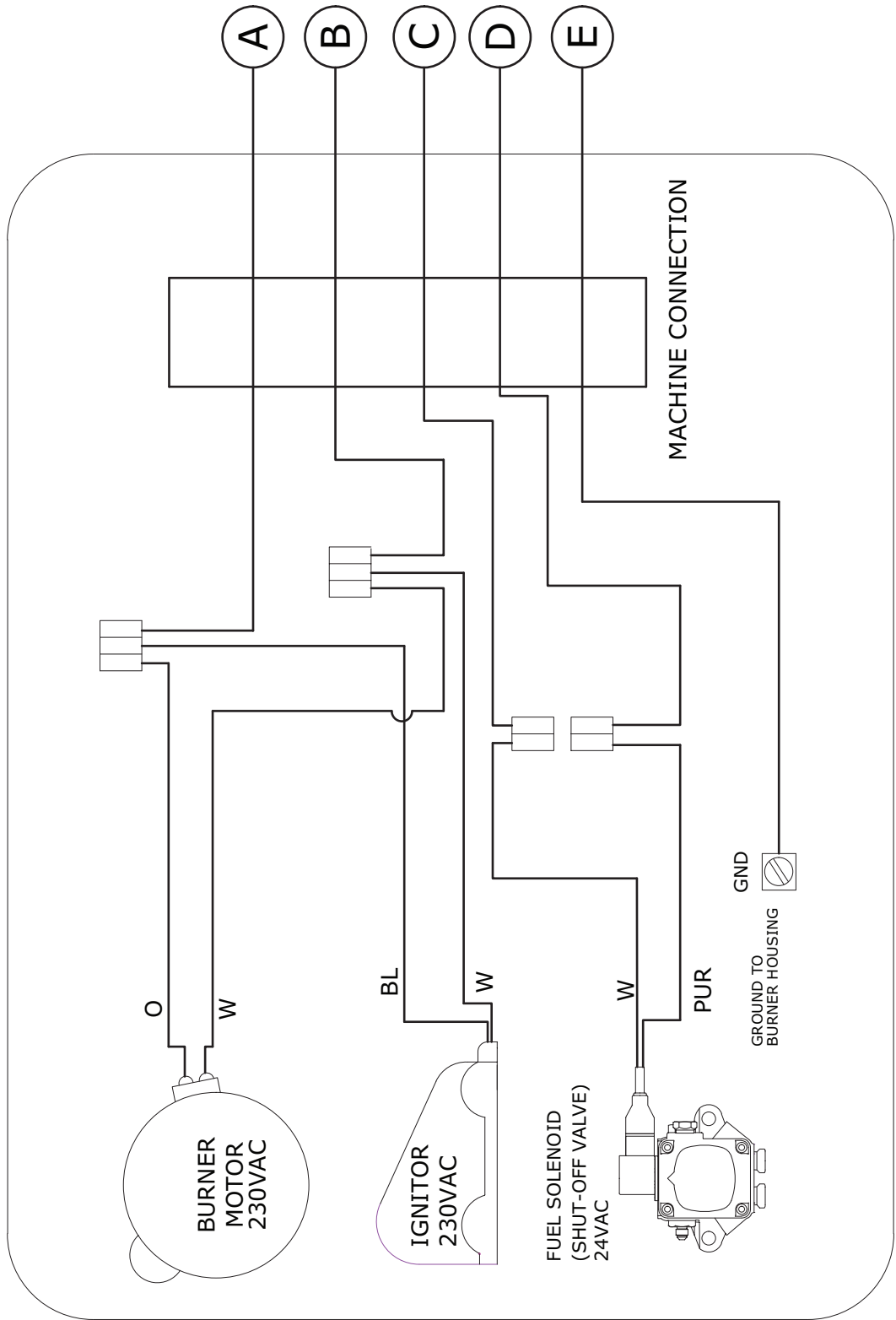

If you need **SERVICE** on your pressure washer, contact your local Hotsy dealer or visit www.Hotsy.com. Smart phone users scan the code below to link directly to the Service Request page.



To **REGISTER** your pressure washer, please visit our Warranty Registration page at www.hotsy.com/WarrantyRegistration.aspx or scan the code below with your smart phone.

