

KÄRCHER

**G210FA
G300FA
G390FA**

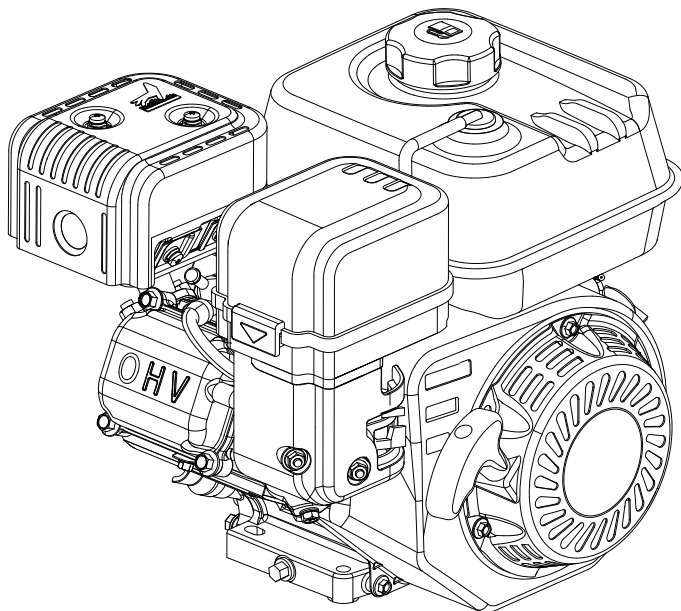

**Register
your product**
www.kaercher.com/welcome



97687610 (03/22)

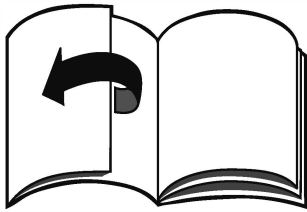

A

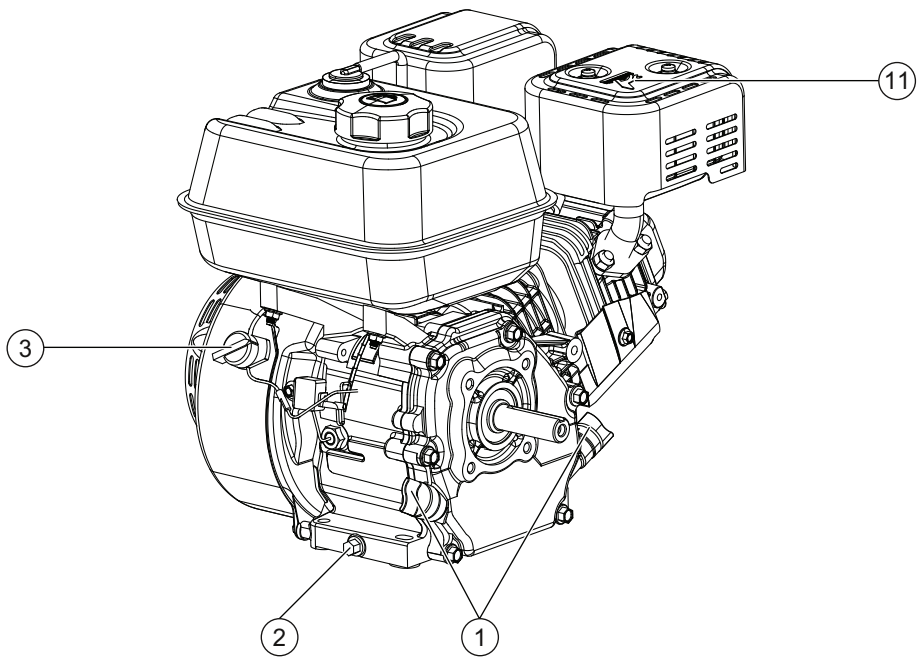
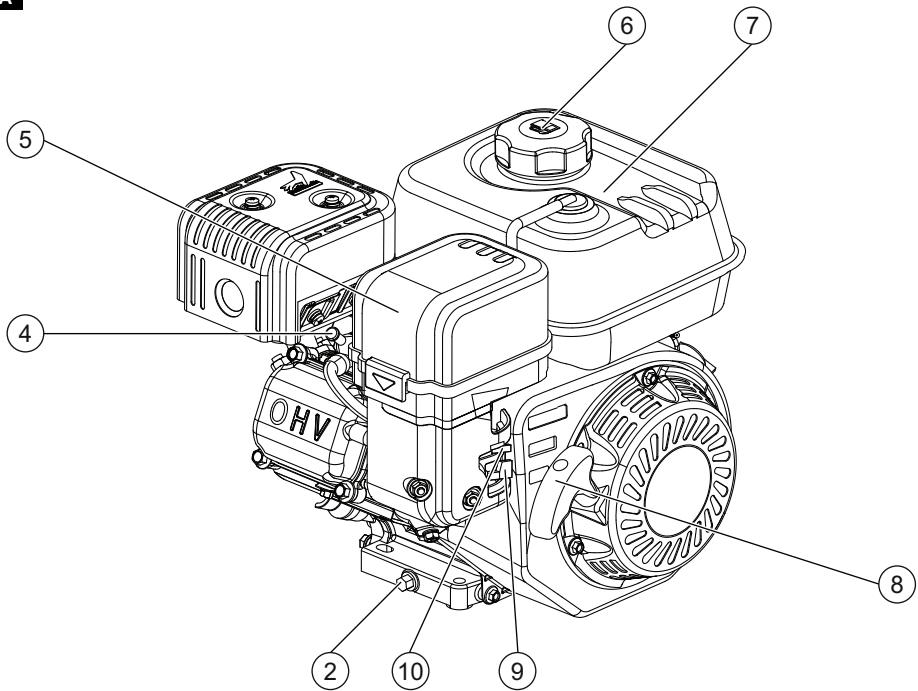

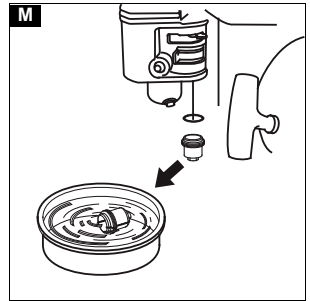
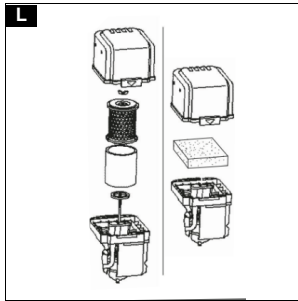
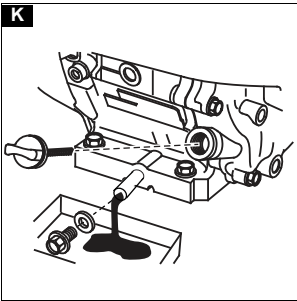
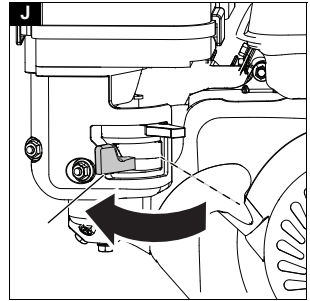
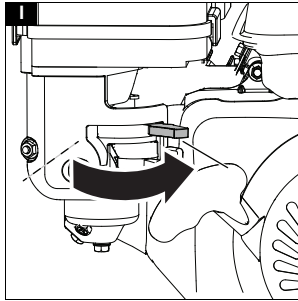
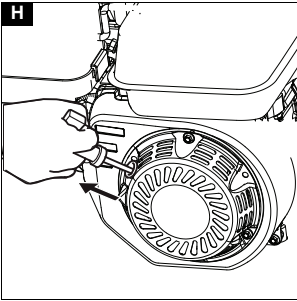
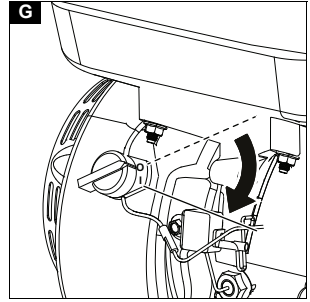
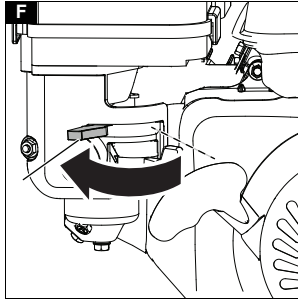
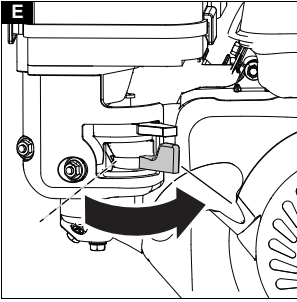
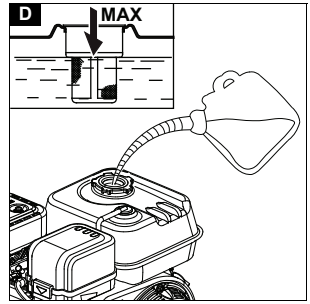
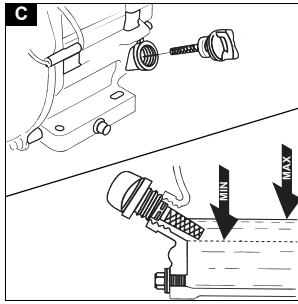
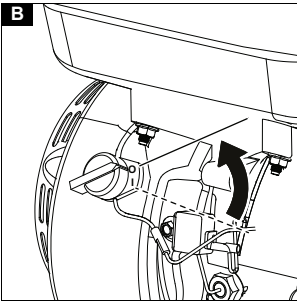

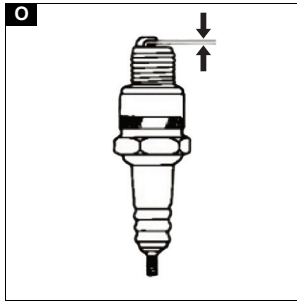
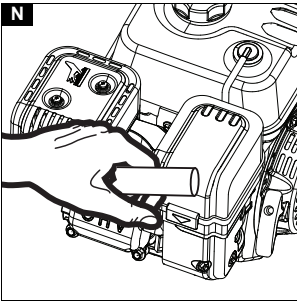

Contents

General notes	6
Safety instructions	6
Description of the appliance	6
Initial start-up	6
Operation	7
Transportation	7
Storage	7
Care and maintenance	7
Troubleshooting guide	9
Technical data	9

General notes



Read these original operating instructions and the safety instructions chapter before using the device for the first time.

Act in accordance with them.

Keep them safe for future reference or for future owners.

Safety instructions

⚠ DANGER

- Only those who understand these operating instructions may run the engine.
- Do not operate this appliance in areas where there is a risk of explosion.
- When using the device in hazard zones (e.g. service stations), adhere to the respective safety regulations.
- Explosion hazard due to unsuitable fuel. Only fill the fuel specified in the operating instructions.
- Do not operate the device if fuel has been spilled. In such a case, move the device to another location and avoid any sparking.
- Only keep the fuel in permitted containers.
- Do not store fuel in the proximity of naked flames or devices such as ovens, heating boilers, water heaters, etc. that have a pilot light or may generate sparks. Do not use or spill fuel in the above environment.
- Do not smoke or use open fire during refueling or in fuel storage areas.
- Do not overfill the tank. Do not exceed the maximum fuel level mark in the tank inlet.
- Only allow refueling in a well-ventilated space and when the engine is off. The fuel is extremely flammable and explosive under certain conditions. Ensure that close the fuel tank lid when refueling is complete.
- In case of repeated or prolonged contact with the fuel and the housing, avoid inhaling fuel.
- Cool the warm engine for 2 minutes before refueling.
- Cool the engine down before store in a confined space.
- Keep easily flammable objects at least 2 m away from the muffler.
- Do not operate the device without a muffler. Check the muffler regularly and clean or replace it if necessary.
- Do not operate the device in forests, bushy or grassy areas if the exhaust pipe is not equipped with a spark catcher.
- Do not run the motor with the air filter removed or without a cover over the intake opening.
- Do not adjust any control springs, governor control linkage or other parts that could increase the speed of the motor.

- Do not touch any hot parts such as the muffler, cylinder or cooling fins.
- Never bring your hands and feet close to rotating parts.
- Do not touch the ignition cable or the spark plug while the engine is running.

⚠ WARNING

- Children and minors must not use the device.
- Children must be supervised to prevent them from playing with the appliance.
- Exhaust gases are toxic. Never breathe in the exhaust gases. Ensure rooms where the device is operated are sufficiently ventilated and that exhaust gases can be conducted away.
- Do not run the engine if the fuel system is damaged or leaking. Regularly inspect the fuel system and replace damaged parts.
- These safety tips in the instructions do not cover all situations of use. As a rule, ensure you observe all safety instructions during maintenance and operation.

⚠ CAUTION

- To avoid fire hazard or damage to the engine, the cooling fins and starter rope must be free of grass or other dirt.

ATTENTION

- Use only original parts from the engine manufacturer. Parts from other sources can damage the engine and shorten its service life.
- To avoid damaging the starter, do not pull the starter rope while the engine is running.
- Only use fresh fuel. Old fuel can cause residue in the carburettor and affect the engine's performance.

Description of the appliance

Illustration A

- ① Oil filling screw with the oil dipstick
- ② Oil drain screw
- ③ Engine switch
- ④ Spark plug
- ⑤ Air filter
- ⑥ Fuel tank lid
- ⑦ Fuel tank
- ⑧ Starter rope
- ⑨ Fuel cock
- ⑩ Choke
- ⑪ Muffler

Initial start-up

⚠ DANGER

Unsuitable fuel

Risk of explosion

Only use gasoline fuel. Unsuitable fuels, such as diesel fuel, must not be used.

Never use stale gasoline fuel.

Never mix the gasoline fuel with oil.

Ensure that neither dirt nor water reaches the fuel tank.

ATTENTION

Operate the engine without an air filter

Engine wear increasing

Ensure that run the engine with the air filter.

1. Place the appliance on a horizontal surface.
2. Turn off the engine switch.

Illustration B

3. Check engine for fuel or oil leakage. Eliminate leakage if any.
4. Check that all screws are tightened. All covers must be fixed in place. Tighten loose connectors.
5. Check the surroundings of the muffler for dirt. Remove any dirt present.
6. Check the air filter for dirt and damage. Clean the air filter depending on the degree of contamination.
7. Check the oil level. For more information, see Chapter *Checking the oil level*.

Illustration C

8. Unscrew the fuel tank lid.
9. Refill the tank.

Illustration D

Note

- Please use gasoline fuel that matches the specifications of the environment.
- Do not exceed the maximum level, i.e. the filter plane.

(For more information, see Chapter *Technical data*.)

10. Close the fuel tank lid.
11. Check the device driven by the engine for operational safety. If the device is out of order, do not start the engine.

Operation

Operation

1. Open the fuel cock.

Illustration E

2. Close the choke.

Illustration F

Note

Do not close the choke while the engine is warm.

3. Turn on the engine switch.

Illustration G

4. Slowly pull the starter rope until you feel resistance.

Illustration H

5. Use both hands to quickly pull the starter rope all the way out.
6. Slowly release the starter rope to the default state.

ATTENTION

Incorrect operation

Damage to the starter

Slowly release the starter rope back after starting.

7. If the engine is not started, repeat steps 4-6.
8. As soon as the engine has warmed up and is running smoothly, open the choke.

Illustration I

Finishing operation

1. Turn off the engine switch.

Illustration B

2. Close the fuel cock.

Illustration J

Transportation

⚠ DANGER

Fuel or spilled fuel

Risk of igniting spontaneously

Keep the engine level during transportation to prevent fuel spillage.

⚠ CAUTION

Failure to observe the weight

Risk of injury and damage

Be aware of the weight of the device during transportation.

Allow the engine to cool down for at least 15 minutes before shipment. After the engine has cooled down, move it to the transport vehicle.

Storage

⚠ DANGER

Flammable fuel

Risk of explosion

Do not store the engine near fire or electrical appliances if there is still fuel in the tank.

⚠ CAUTION

Failure to observe the weight

Risk of injury and damage

Be aware of the weight of the device during storage.

ATTENTION

Damage of the engine by water seeping

Avoid water seeping into the muffler or air filter.

ATTENTION

Moisture

Risk of corrosion

Do not store the engine in a place with high air humidity.

1. Remove the spark-plug connector.
2. Change the oil.
For more information, see Chapter *Changing the oil*.
3. Allow the engine to cool down for at least 30 minutes.
4. Clean the outer surface of the engine.
5. Repair damaged paint and slightly apply oil on surfaces prone to rust.
6. When storing the appliance for more than one month, drain the fuel.
7. Unscrew the spark plug.
8. Put 5 - 10 cm³ engine oil into the cylinder.
9. Pull the starter rope several times to spread the oil in the engine.
10. Screw in the spark plug.
11. Pull the starter rope slowly until you feel resistance.
12. Slowly release the starter rope.
13. Store in a dry place.

Note

- Even if the tank is empty, close the fuel cock to prevent leakage.
- Place the engine horizontally, otherwise oil or fuel may spill.
- Cover the engine to protect it from dust.

Care and maintenance

⚠ WARNING

Inadvertently starting up device

Risk of injury

Remove the spark plug prior to all work on the device.

⚠ CAUTION

Risk of burns from hot surfaces.

Allow the device to cool down prior to all work.

⚠ WARNING

Improper servicing

The third-party personnel can impair the functionality and safety of the engine.

Only allow the authorised Customer Service personnel to repair or replace the spare parts.

Before doing work with the appliance, you must place the appliance on a horizontal surface.

Maintenance intervals

	Before each use	Once after 1 month / Once after 20 hours	Every 3 months / Every 50 hours	Every 6 months / Every 100h hours	Yearly / Every 300 hours	Every 2 years
Check and tighten the bolts and nuts.	X					
Check the engine for oil or fuel leaks. Eliminate the existing leaks.	X					
Check and replenish the engine oil.	X					
Check the air filter.	X					
Change the engine oil.		X		X		
Clean the air filter.			X			
Clean the sediment cup.				X		
Check and clean the spark plug.				X		
Clean the spark arrester (not included in the delivery).				X		
Replace the spark plug.					X	
Clean and replace the air filter element (only paper filter).					X A	
Check and adjust the tappet clearance.					O	
Clean the fuel tank and the fuel filter.					O	
Remove the burner residue from the burner chamber.					O	
Check the fuel line. Replace it if necessary.						O

X: Implemented by users

O: Implemented by Customer Service

A: Service more frequently when used in dusty areas

Maintenance work

Checking the oil level

Note

Put the engine in a horizontal position and check the oil level in the stopped state.

- Turn off the engine switch.
- Place the appliance on a horizontal surface.
- Remove the dipstick and wipe the dipstick.

Illustration C

- Insert (do not screw in) the dipstick into the oil filling port until the stop, and pull it out again. Read the value of the oil level.
- In case of low oil level: Refill oil (SAE 10 W30 or SAE 15 W40) to the lower edge of the oil filling port. (For the maximum refueling quantity, see Chapter *Technical data*.)
- Screw in the dipstick.

Changing the oil

Note

Change the oil when the engine is warm.

- Remove the dipstick and wipe the dipstick.

- Unscrew the oil drain bolt and collect the drained oil.

Illustration K

- Place the oil drain screw and tighten it.
- Place the appliance on a horizontal surface.
- Refill oil (SAE 10 W30 or SAE 15 W40) to the lower edge of the oil filling port. (For the maximum refueling quantity, see Chapter *Technical data*).
- Screw in the dipstick.

Checking the air filter

- Unscrew the screw of the air filter housing.
- Remove the air filter housing.

Illustration L

- Clean or replace the dirty filter element.
- Replace the damaged filter element.
- Reinstall the air filter.
- Reinstall the air filter housing.

Cleaning the sediment cup

- Close the fuel cock.
- ###### Illustration J
- Unscrew the sediment cup.
- ###### Illustration M
- Remove the O-ring.
 - Clean the sediment cup and the O-ring using a non-flammable solvent and allow them to dry.
 - Insert the O-ring into the fuel cock.

6. Screw in the sediment cup and tighten it.
7. Open the fuel cock.

Illustration E

8. Check the sediment cup for leaks.
9. Replace the O-ring in case of leaks.

Checking the spark plug

⚠ WARNING

Incorrect installation of spark plug

*Cause the engine to overheat / damage to the engine and the thread in the cylinder head
Do not tighten the spark plug too loosely or excessively.
Observe the information on tightening the spark plug.*

1. Remove the spark plug connector.

Illustration N

2. Clean the spark plug and the surroundings.
3. Unscrew the spark plug.
4. Replace a spark plug with worn electrodes or broken insulators.
5. Check the distance between the electrodes of the spark plug.

For more information, see contact clearance in Chapter *Technical data*.

Illustration O

6. Carefully screw in the spark plug by hand. Do not cant the thread.
7. Turn the spark plug up to the stop using the spark plug wrench, and tighten it as follows:
 - a Tighten used spark plugs with 1/8 - 1/4 rotation.
 - b Tighten a new spark plug with 1/2 rotation.
8. Push on the spark plug connector.

Troubleshooting guide

⚠ WARNING

Inadvertently starting up device

Risk of injury

Remove the spark plug prior to all work on the device.

⚠ CAUTION

Risk of burns from hot surfaces.

Allow the device to cool down prior to all work.

Engine does not start

The engine switch has been turned off.

1. Turn on the engine switch.

The fuel cock is closed.

1. Open the fuel cock.

The choke is opened.

1. Close the choke unless the engine is warm.

There is insufficient fuel.

1. Refill the tank.

Fuel type does not match or old fuel was filled.

1. Drain the fuel tank and the carburettor.

2. Add new fuel of the specified type.

The spark plug is soiled. / Distance between electrodes is incorrect.

1. Check the spark plug for damage.

2. Clean the spark plug.

3. Check the distance between the electrodes.

The spark plug is defective.

1. Replace the spark plug.

The spark plug is wet.

1. Dry the spark plug.

2. Screw in the spark plug.

Low engine power

The air filter is blocked.

1. Check and clean the air filter.

There is a lack of fuel.

1. Refill the tank.

Fuel type does not match or old fuel was filled.

1. Drain the fuel tank and the carburettor.

2. Add new fuel of the specified type.

Compression too low or does not exist

Spark plug is not properly tightened.

1. Tighten the spark plug.

Technical data

		G210FA	G300FA	G390FA
Device performance data				
Power	kW	4.4	6.8	8.5
Cylinder diameter	mm	70	80	88
Piston stroke	mm	55	60	64
Engine capacity	cm ³	212	302	389
Fuel type		unleaded vehicle petrol (86 ROZ)	unleaded vehicle petrol (86 ROZ)	unleaded vehicle petrol (86 ROZ)
Fuel tank capacity	l	3.0	5.5	6.5
Oil type		SAE 10 W30 / SAE 15 W40	SAE 10 W30 / SAE 15 W40	SAE 10 W30 / SAE 15 W40
Engine oil volume	l	0.6	0.95	1.1
Spark plug type		F7RTC	F7RTC	F7RTC
Contact clearance	mm	0.7 - 0.8	0.7 - 0.8	0.7 - 0.8
Dimensions and weights				
Weight	kg	16	26	31
Length	mm	317	380	405
Width	mm	376	430	450
Height	mm	345	410	451
CO₂Emissions according to the measurement procedure of EU regulation 2016/1628 Euro V				
Motor	g/kWh	880.45	817.85	817.85

Subject to technical modifications.



THANK YOU!
MERCI! DANKE! ¡GRACIAS!



Registrieren Sie Ihr Produkt und profitieren Sie von vielen Vorteilen.

Register your product and benefit from many advantages.

Enregistrez votre produit et bénéficiez de nombreux avantages.

Registre su producto y aproveche de muchas ventajas.

www.kaercher.com/welcome



Bewerten Sie Ihr Produkt und sagen Sie uns Ihre Meinung.

Rate your product and tell us your opinion.

Évaluer votre produit et dites-nous votre opinion.

Reseñe su producto y díganos su opinión.



www.kaercher.com/dealersearch

Alfred Kärcher SE & Co. KG
Alfred-Kärcher-Str. 28-40
71364 Winnenden (Germany)
Tel.: +49 7195 14-0
Fax: +49 7195 14-2212

