

HWE

Electric Powered - Electric Heated



Operator's Manual

Pressure Washer

MODELS

HWE-4020C

1.109-646.0

HWE-4030C

1.109-647.0

HWE-4020F

1.109-958.0

HWE-4030F

1.109-959.0

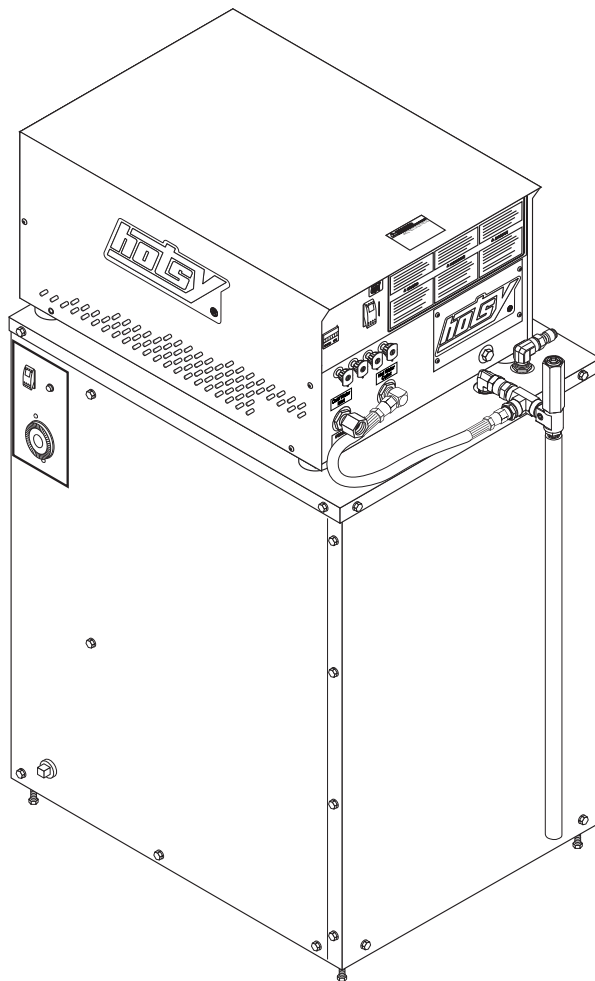

Scan or Click to View
The Hotsy Safety Video



For the Hotsy Dealer nearest
you, consult our web page at
www.hotsy.com



Intertek



8.941-225.0-BE 05/05/25

MACHINE DATA LABEL

Model: _____

Date of Purchase: _____

Serial Number: _____

Dealer: _____

Address: _____

Phone Number: _____

Sales Representative: _____

TABLE OF CONTENTS

Machine Data Label	2
Table of Contents	3
How To Use This Manual	4

Safety

Introduction & Safety Information	5
IMPORTANT SAFETY INFORMATION	6
Pre-Operation Check.....	8

Operations

Assembly Instructions.....	10
Operating Instructions	12
Detergents & General Cleaning Techniques	13
Shutdown Procedures	15

Maintenance

Storage.....	16
Preventative Maintenance	17
Maintenance Schedule	17
Oil Change Record	17
Troubleshooting.....	19

HOW TO USE THIS MANUAL

This manual contains the following sections:

- How to Use This Manual
- Safety
- Operations
- Maintenance
- Parts List

The HOW TO USE THIS MANUAL section will tell you how to find important information for ordering correct repair parts.

Parts may be ordered from authorized dealers. When placing an order for parts, the machine model and machine serial number are important. Refer to the MACHINE DATA box which is filled out during the installation of your machine. The MACHINE DATA box is located on the inside of the front cover of this manual.

Model: _____
Date of Purchase: _____
Serial Number: _____
Dealer: _____
Address: _____
Phone Number: _____
Sales Representative: _____

The model and serial numbers will be found on a decal attached to the pressure washer.

The SAFETY section contains important information regarding hazardous or unsafe practices of the machine. Levels of hazards are identified that could result in product damage, personal injury, or severe injury resulting in death.

The OPERATIONS section is to familiarize the operator with the operation and function of the machine.

The MAINTENANCE section contains preventive maintenance to keep the machine and its components in good working condition. They are listed in this general order:

- Preventative Maintenance
- Maintenance Schedule
- Oil Change Record
- Troubleshooting

The PARTS LIST section contains assembled parts illustrations and corresponding parts list. The parts lists include a number of columns of information:

- **REF** – column refers to the reference number on the parts illustration.
- **PART NO.** – column lists the part number for the part.
- **QTY** – column lists the quantity of the part used in that area of the machine.
- **DESCRIPTION** – column is a brief description of the part.
- **NOTES** – column for information not noted by the other columns.

NOTE: If a service or option kit is installed on your machine, be sure to keep the KIT INSTRUCTIONS which came with the kit. It contains replacement parts numbers needed for ordering future parts.

NOTE: The manual part number is located on the lower right corner of the front cover.

SAFETY

Introduction & Safety Information

Thank you for purchasing this Hotsy Pressure Washer.

This manual covers the operation and maintenance of the HWE-4020C, HWE-4030C, HWE-4020F and HWE-4030F washers. All information in this manual is based on the latest product information available at the time of printing.

We reserve the right to make changes at any time without incurring any obligation.

Owner/User Responsibility:

The owner and/or user must have an understanding of the manufacturer's operating instructions and warnings

before using this pressure washer. Warning information should be emphasized and understood. If the operator is not fluent in English, the manufacturer's instructions and warnings shall be read to and discussed with the operator in the operator's native language by the purchaser/owner, making sure that the operator comprehends its contents.

Owner and/or user must study and maintain for future reference the manufacturers' instructions.

The operator must know how to stop the machine quickly and understand the operation of all controls. Never permit anyone to operate the engine without proper instructions.

Save These Instructions

This manual should be considered a permanent part of the machine and should remain with it if machine is resold.

When ordering parts, please specify model and serial number. Use only identical replacement parts. This machine is to be used only by trained operators.

SAFETY

IMPORTANT SAFETY INFORMATION

WARNING: When using this machine basic precautions should always be followed, including the following:

AVERTISSEMENT: En utilisant cette machine, des précautions de base devraient toujours être observées, y compris ce qui suit :



WARNING: To reduce the risk of injury, read operating instructions carefully before using.

AVERTISSEMENT: Pour réduire le risque de blessures, lire attentivement les instructions de fonctionnement avant l'utilisation.

1. Read the owner's manual thoroughly. Failure to follow instructions could cause malfunction of the machine and result in death, serious bodily injury and/or property damage.

2. Know how to stop the machine and bleed pressure quickly. Be thoroughly familiar with the controls.
3. Stay alert — watch what you are doing.
4. All installations must comply with local codes. Contact your electrician, plumber, utility company or the selling dealer for specific details.

WARNING: Must be plugged into properly wired three hole grounded outlet that accommodates plug on power cored. Failure to comply could result in electrical shock.

AVERTISSEMENT: Doit être raccordé dans une sortie à trois trous mise à la masse et correctement câblée qui peut accueillir une fiche sur un cordon d'alimentation. Le non-respect de cette consigne pourrait causer un choc électrique.



DANGER: Keep wand, hose, and water spray away from electric wiring or fatal electric shock may result.

DANGER: Garder le jet d'eau à l'écart de tout câblage électrique ou des chocs électriques mortels pourraient survenir.

5. To protect the operator from electrical shock, the machine must be electrically grounded. It is the responsibility of the owner to connect this machine to a UL grounded receptacle of proper voltage and amperage ratings. Do not spray water on or near electrical components. Do not touch machine with wet hands or while standing in water. Always disconnect power before servicing.



WARNING: Spray gun kicks back — hold with both hands.

AVERTISSEMENT: Le pistolet pulvérisateur peut présenter un risque de retour; le tenir avec les deux mains.

6. Grip spray-gun and wand securely before starting this machine. Failure to do this could result in bodily injury from a whipping wand.

WARNING: Flammable liquids can create fumes which can ignite, causing property damage or severe injury.

AVERTISSEMENT: Des liquides inflammables peuvent produire des vapeurs qui peuvent s'enflammer, causant ainsi des dommages à la propriété ou des blessures graves.



WARNING: Risk of explosion. Do not install or operate near any flammable liquids. Do not spray flammable liquids.

AVERTISSEMENT: Risque d'explosion. Ne pas installer ou utiliser à proximité de liquides inflammables. Ne pas pulvériser de liquides inflammables.

WARNING: Before obtaining access to electric terminals, all supply circuits must be disconnected

AVERTISSEMENT: Avant d'accéder aux bornes électriques, déconnecter tous les circuits d'alimentation.

7. Electrical appliances shall be installed only in locations where combustible dusts and flammable gases or vapors are not present. Do not store or use gasoline near this machine. This product incorporates parts that tend to produce arcs or sparks and, therefore, when located in a garage, it should be in a room or enclosure provided for the purpose, or should be 18" (45cm) or more above the floor.

SAFETY



WARNING: High pressure developed by these machines will cause personal injury or equipment damage. Use caution when operating.

AVERTISSEMENT: La haute pression générée par ces machines causera des lésions corporelles ou des dommages à l'équipement. Faire preuve de prudence lors de

l'utilisation. Cet équipement doit être utilisé uniquement par des opérateurs formés.

WARNING: Risk of injection or severe injury. Keep clear of nozzle. Do not direct discharge stream at persons or animals. This equipment is to be used only by trained operators. Cet équipement doit être utilisé uniquement par des opérateurs formés.

AVERTISSEMENT: Risque d'injection ou de blessures graves. Se tenir à l'écart de la buse. Ne pas diriger le débit de décharge vers des personnes ou des animaux.



WARNING: High pressure spray can cause paint chips or other particles to become airborne and fly at high speeds. To avoid personal injury, eye and foot safety devices must be worn.

AVERTISSEMENT: Un jet haute pression peut écailler la peinture ou provoquer l'émission d'autres

particules dans l'air et leur projection à hautes vitesses. Pour éviter les lésions corporelles, une protection des yeux, du visage, des mains et des pieds doit être portée lors de l'utilisation de cet équipement.

8. Always wear properly rated eye protection such as safety goggles or face shield while spraying. (Safety glasses do not provide full protection.)
9. Never make adjustments on machine while it is in operation.
10. Machines with spray guns should not be operated with the spray gun in the off position for extended periods of time as this may cause damage to the pump.



WARNING: Protect machine from freezing.

AVERTISSEMENT: Protéger la machine contre le gel.

11. Protect discharge hose from vehicle traffic and sharp objects.
12. To Prevent a serious injury, be certain quick coupler on discharge hose has locked before using pressure washer.
13. Before disconnecting discharge hose from hot water outlet, disconnect power supply, open spray gun to relieve back pressure in hose and use protective gloves.
14. Do not allow acids, caustic or abrasive fluids to pass through the pump.
15. Inlet water supply must be cold and clean fresh water and not hotter than 145°.
16. The best insurance against an accident is precaution and knowledge of the machine.
17. Hotsy will not be liable for any changes made to our standard machines, or any components not purchased from Hotsy.
18. To reduce the risk of injury, close supervision is necessary when a machine is used near children. Do not allow children to operate the pressure washer. This machine must be attended during operation.
19. Do not overreach or stand on unstable support. Keep good footing and balance at all times.
20. Follow the maintenance instructions specified in the manual.
21. When making repairs disconnect from electrical source.
22. Do not operate this product when fatigued or under the influence of alcohol or drugs. Keep operating area clear of all persons.

CAUTION: Hot surfaces - use only designated areas of Lance (wand or gun).

ATTENTION: Les surfaces - Utiliser uniquement les zones désignées de la lance (tige ou pistolet).

SAFETY



WARNING: *If connection is made to a potable water system, the system shall be protected against back flow.*

AVERTISSEMENT: *Si une connexion est établie avec un réseau d'eau potable, le réseau doit être protégé contre le retour d'eau.*



WARNING: *Do not spray machine or any people, animals or electrical parts.*

AVERTISSEMENT: *Ne pas vaporiser sur la machine ou les gens, les animaux ou les pièces électriques.*



WARNING: *Be extremely careful when using a ladder, scaffolding or any other relatively unstable location. The cleaning area should have adequate slopes and drainage to reduce the possibility of a fall due to slippery surfaces.*

AVERTISSEMENT: *Faire preuve d'une extrême prudence au moment d'utiliser une échelle, des échafaudages ou toute autre surface relativement instable.*

La zone de nettoyage doit avoir une pente et un drainage adéquats pour réduire la possibilité d'une chute due à une surface glissante.

Pre-Operation Check

- Heat module water level
- Pump oil (SAE 10W-40 non-foaming oil)
- Cold water supply (6 gpm • 5/8" • 20 psi)
- Proper power supply
- Hose, wand, nozzles (nozzle sizes per serial plate)
- Water filter (intact, non restrictive)
- Read installation and operation instructions



Follow the maintenance instructions specified in the manual.

OPERATIONS

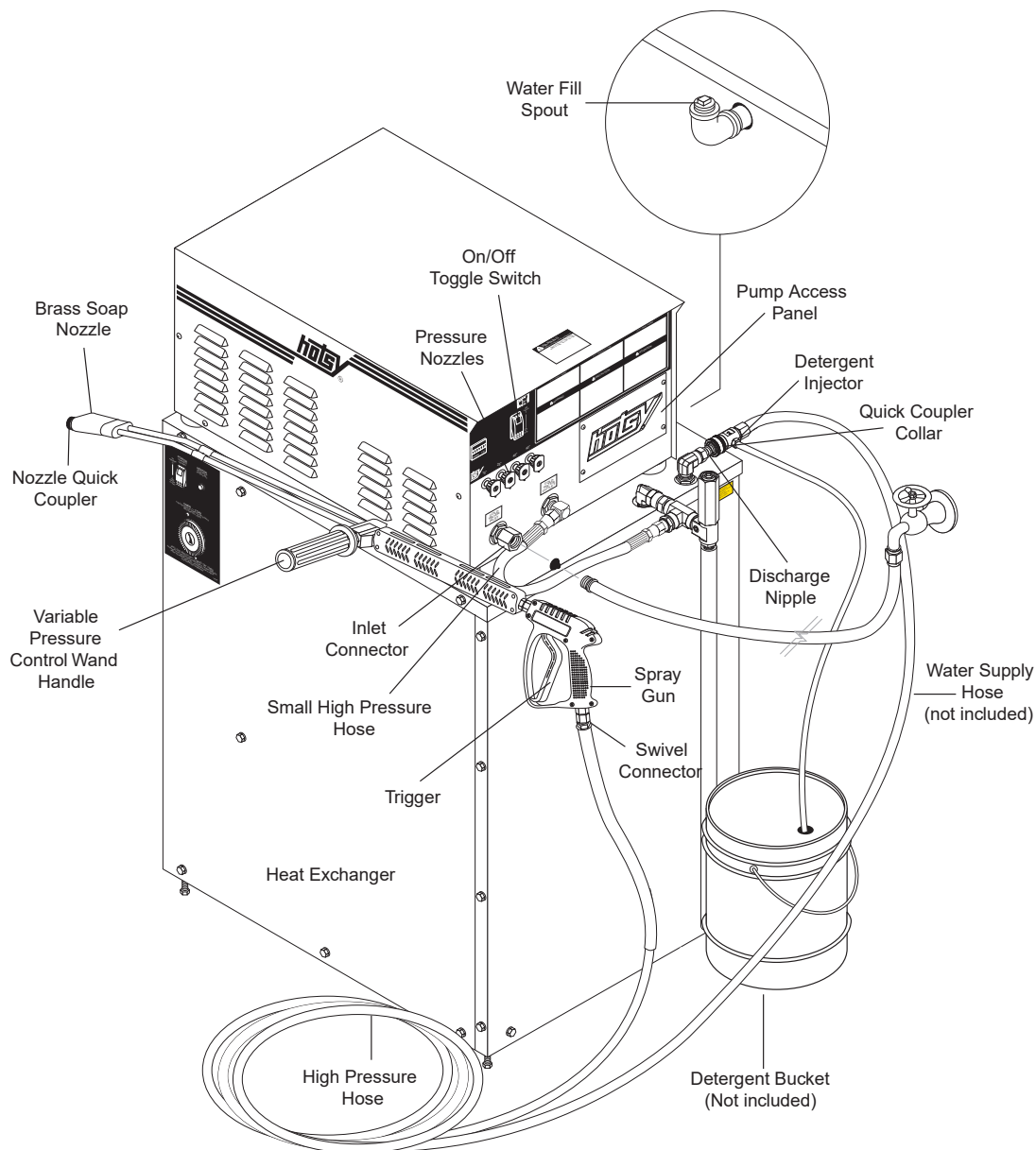

Pump — Delivers a specific gpm to the high pressure nozzle which develops pressure.

Spray Gun — Controls the application of water and detergent onto cleaning surface with trigger device. Includes safety latch.

Detergent Injector — Allows you to siphon and mix detergents.

Wand — Must be connected to the spray gun.

Heat Exchanger — Has a stainless steel coil suspended into an 80 gallon water tank that is heated to 180° F (84°c) by heating elements.

High Pressure Hose — Connect one end to water pump high pressure discharge nipple and the other end to spray gun.

Unloader Valve — Safety device which, when the spray gun closes, prevents over pressurization (Not Shown.)

NOTE: If trigger on spray gun is released for more than 2 minutes, water will leak from the pump protector. Warm water will discharge from pump protector onto floor. This system prevents internal pump damage.

ASSEMBLY INSTRUCTIONS

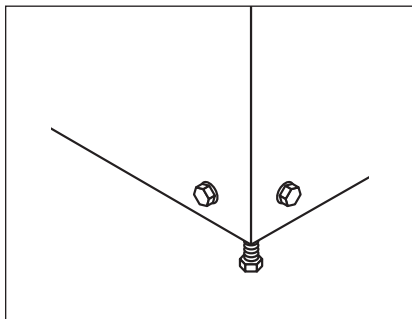

STEP 1: Place machine in a convenient location providing ample support, drainage and room for maintenance. Remove pallet bolts and remove pallet, then re-install bolts to level machine by adjusting (machine must be level).

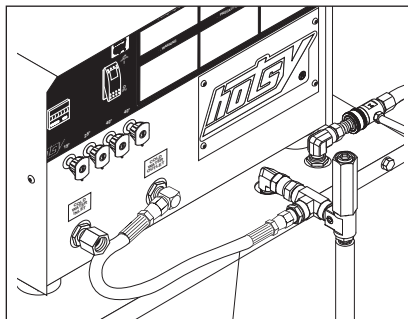

STEP 2: Place the pump package on top of the heat exchange and attach the small high pressure hose to the fittings as shown.

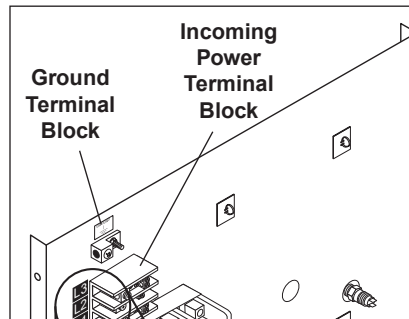

STEP 3: Remove the hex head screws from electrical access panel. **NOTE:** bottom right screw will only loosen; access panel is designed to pivot on this screw. Once access panel is rotated out of the way, attach the electrical harness from the pressure washer to the heating module as follows:

- a. Feed pressure washer wire harness through the upper wire hole located on the side of the machine (See item 16 on Exploded View -Left Side).
- b. On the right side of the incoming power terminal block, connect the black wire to line L1, the red wire to line L2, and the white wire to line L3.
- c. Attach the green wire to the ground terminal block.

CAUTION: Have qualified electrician attach the proper supply cord to the terminal labeled L1, L2 and L3.

ATTENTION: Demander à un électricien qualifié de raccorder le cordon d'alimentation approprié à la borne étiquetée L1, L2 et L3.

STEP 4: Do not turn power on to equipment until the heating module is filled with water, as severe damage may occur to heater elements.

Prior to shipping, a rust inhibitor was added to the hot water tank. This will mix with the added water to prevent rust build-up inside the tank.

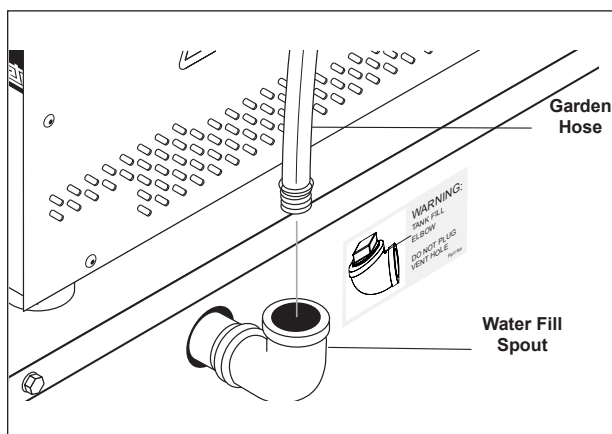

Install water fill spout (item 15, page 20, shipped loose). Spout opening should be facing up. Insert water hose and fill. Do not over fill to allow for thermal expansion. (Maximum is 80 gallons). After heater tank has been filled to the top, operate for one week and then add one quart of oil to slow evaporation. Be sure to replace spout plug, hand tight only.

Turn on main power supply to unit. Set 7 day programmable timer to desired ON/OFF time and switch machine power on, Water will heat up to operating temperature in 30 to 60 minutes. The heater will turn off automatically when 200°F is reached. Water will come out of heater fill spout due to heat expansion. However, this will stop after temperature is reached.

Leave main power on to the machine to ensure hot water on pump start up.

ASSEMBLY INSTRUCTIONS

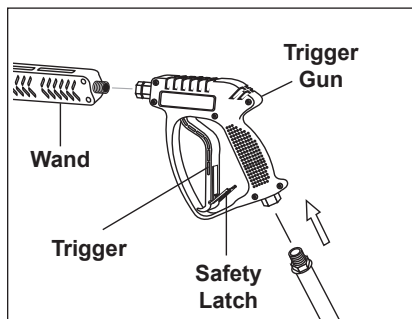

STEP 5: Attach variable pressure control wand to spray gun using Teflon tape on threads to prevent leakage. Position safety latch to prevent trigger from being pulled.

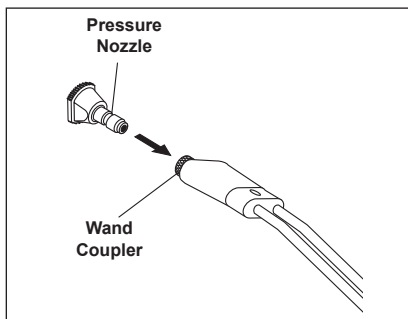

STEP 6: Pull the spring-loaded collar of the wand coupler back to insert your choice of pressure nozzle.

Caution: *Never replace nozzles without engaging the safety latch on the spray gun trigger.*

ATTENTION: *Ne jamais remplacer les buses sans d'abord mettre le dispositif de sécurité sur la détente du pistolet pulvérisateur.*

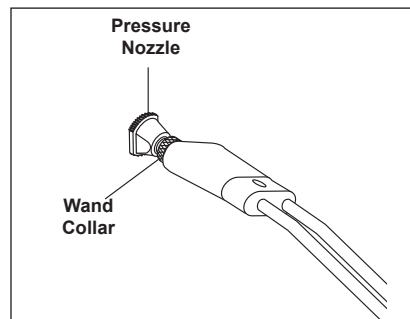

STEP 7: Release the coupler collar and push the nozzle until the collar clicks. Pull the nozzle to make sure it is seated properly.

Warning: *These machines are designed for indoor use. Machine must be stored indoors when not in use.*

AVERTISSEMENT: *La machine doit être entreposée à l'intérieur lorsqu'elle n'est pas utilisée. Ces machines sont conçues pour une utilisation à l'intérieur.*

OPERATING INSTRUCTIONS

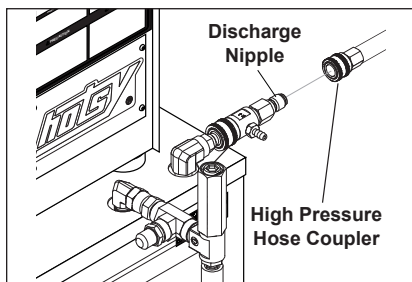

STEP 1: Connect the high pressure hose quick coupler to the discharge nipple by sliding the quick coupler collar back and inserting the quick coupler onto the discharge nipple and pushing the quick coupler collar forward to secure it. Secure desired pressure nozzle into variable pressure wand coupler.

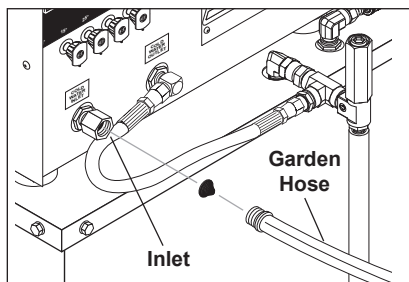

STEP 2: Connect water supply hose (garden hose) to inlet connector. Do not allow acid or abrasives to be pumped through system. Turn on water.

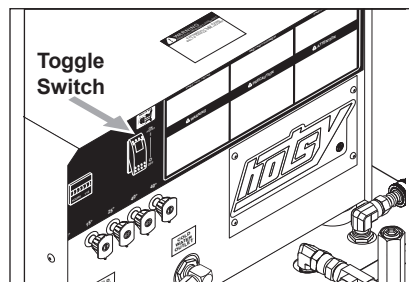

STEP 3: Place toggle switch in the ON position and then pull the trigger on the spray gun to activate a pressure switch which will then start the machine. The ON position is for auto shut down.

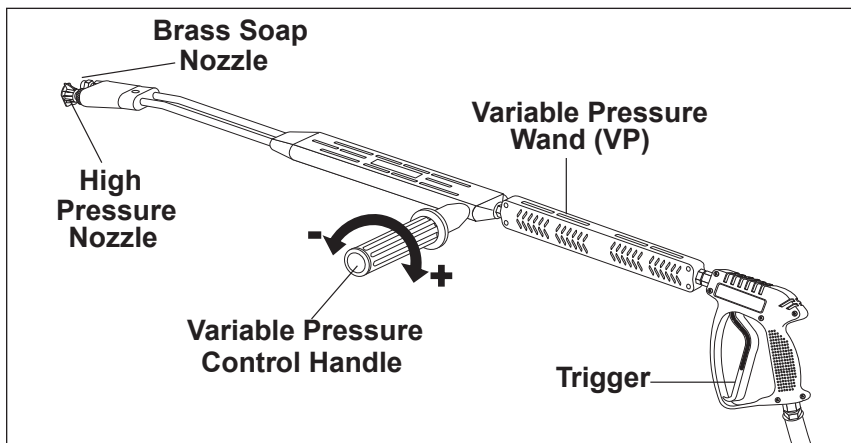

STEP 4: Turn the variable pressure control handle clockwise to increase pressure.

NOTE: Selection of high or low pressure is accompanied by turning the handle. High pressure nozzle must be inserted at end of wand to obtain high pressure. To apply soap read Detergents & General Cleaning Techniques section.

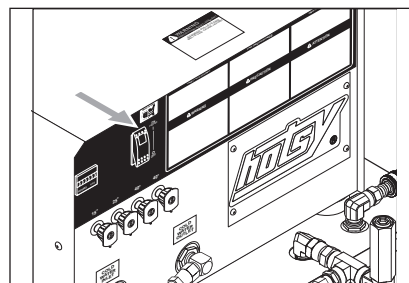

STEP 5: To stop machine, release the spray gun and machine will automatically stop in approximately 12 seconds. If machine is going to be unattended for long periods of time, turn water supply off and place switch in off position.

NOTE: When removing or replacing hoses, wand and nozzles, move switch to off position, open spray gun to release pressure before removing discharge hose.

OPERATIONS

Detergents & General Cleaning Techniques



WARNING: Some detergents may be harmful if inhaled or ingested, causing severe nausea, fainting or poisoning. The harmful elements may cause property damage or severe injury.

AVERTISSEMENT: Certains détergents peuvent être dangereux s'ils sont inhalés ou ingérés, provoquant de fortes nausées, des évanouissements et l'empoisonnement. Les éléments dangereux peuvent causer des dommages à la propriété ou des blessures graves.

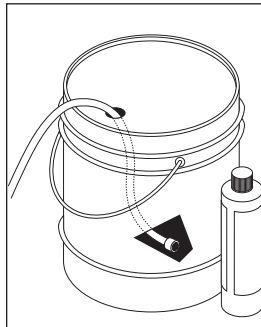

STEP 1: Use detergent designed specifically for pressure washers. Household detergents could damage the pump. Prepare detergent solution as required by the manufacturer. Fill a container with pressure washer detergent. Place the filter end of detergent suction tube into the detergent container.

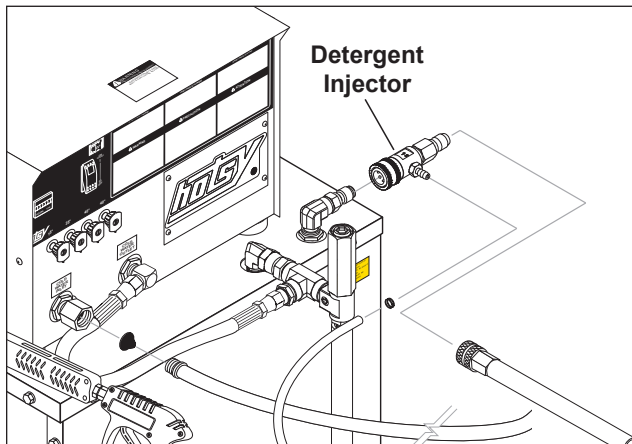

STEP 2: Apply safety latch to spray gun trigger. Open variable pressure wand handle to low pressure which allows water through black detergent nozzle.

NOTE: Detergent cannot be applied during high pressure.

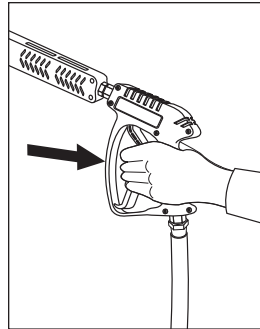

STEP 3: With the motor running, pull trigger to operate machine. Liquid detergent is drawn into the machine and mixed with water. Apply detergent to work area. Do not allow detergent to dry on surface.

IMPORTANT: You must flush the detergent injection system after each use by placing the suction tube into a bucket of clean water, then run the pressure washer in low pressure for 1-2 minutes.

Thermal Pump Protection

If you run your pressure washer for 3-5 minutes without pressing the trigger on the spray gun, circulating water in the pump can reach high temperatures. When the water reaches this temperature, the pump protector engages and cools the pump by discharging the warm water onto the ground. This thermal device prevents internal damage to the pump.

OPERATIONS

Cleaning Tips

Pre-rinse cleaning surface with fresh water. Place detergent suction tube directly into cleaning solution and apply to surface at low pressure (for best results, limit your work area to sections approximately 6 feet square and always apply detergent from bottom to top). Allow detergent to remain on surface 1-3 minutes. Do not allow detergent to dry on surface. If surface appears to be drying, simply wet down surface with fresh water. If needed, use brush to remove stubborn dirt. Rinse at high pressure from top to bottom in an even sweeping motion keeping the spray nozzle approximately 1 foot from cleaning surface. Use overlapping strokes as you clean and rinse any surface. For best surface cleaning action spray at a slight angle.

Recommendations:

Before cleaning any surface, an inconspicuous area should be cleaned to test spray pattern and distance for maximum cleaning results.

If painted surfaces are peeling or chipping, use extreme caution as pressure washer may remove the loose paint from the surface.

Keep the spray nozzle a safe distance from the surface you plan to clean. High pressure wash a small area, then check the surface for damage. If no damage is found, continue to pressure washing.



CAUTION - Never use:

- Bleach, chlorine products and other corrosive chemicals
- Liquids containing solvents (i.e., paint thinner, gasoline, oils)
- Tri-sodium phosphate products
- Ammonia products or acid-based products



ATTENTION: Ne jamais utiliser :

- Insecticides, pesticides ou herbicides
- Eau de Javel, produits à base de chlore et autres produits chimiques corrosifs
- Liquides contenant des solvants (c.-à-d. diluant à peinture, essence, huiles, etc.)
- Produits à base de tripolyphosphate de sodium
- Ammoniac ou produits à base d'acide

These chemicals will harm the machine and will damage the surface being cleaned.

Rinsing

It will take a few seconds for the detergent to clear. Apply safety latch to spray gun. Turn variable pressure control handle to high pressure. NOTE: You can also stop detergent from flowing by simply removing detergent siphon tube from bottle.

SHUTDOWN PROCEDURES

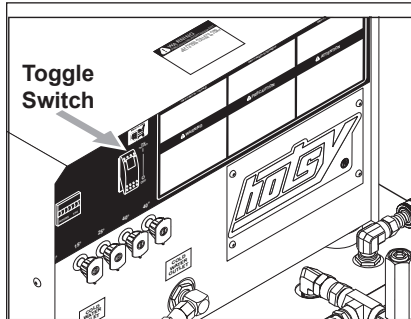

STEP 1: Rinse all lines (and injector) with clean water, to remove any soap residue then turn toggle switch off.

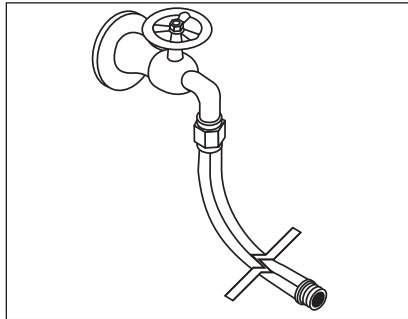

STEP 2: Turn off water supply.

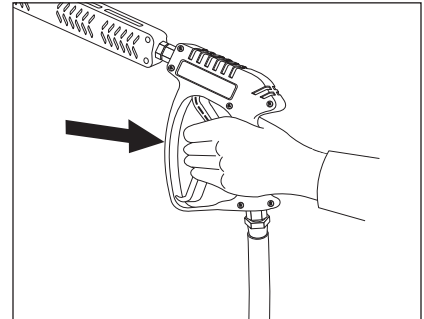

STEP 3: Open spray gun to relieve remaining pressure and remove water supply hose.

In freezing conditions, disconnect water supply and open spray gun to allow water to drain, then turn off motor.

CAUTION: Do not allow pump to run longer than 5 minutes without water. Disconnect all hoses to allow water to drain.

ATTENTION: Suivre les instructions de câblage dans le présent manuel au moment de raccorder le système aux lignes de transport d'électricité. Ne pas laisser la pompe fonctionner pendant plus de X minutes sans eau.

CAUTION: With machine off, open spray gun to release pressure before removing discharge hose.

ATTENTION: Avec la machine hors tension, ouvrir le pistolet pulvérisateur pour relâcher la pression avant de retirer le tuyau de refoulement.

MAINTENANCE

Storage

Pump Storage



CAUTION: Always store your pressure washer in a location where the temperature will not fall below 32° F (0° C). The pump in this machine is susceptible to permanent damage if frozen.

ATTENTION: Toujours entreposer la laveuse à pression dans un endroit où la température ne sera pas inférieure à 32 °C (0 °F). La pompe sur cette machine est susceptible de subir des dommages si elle est exposée au gel.

FREEZE DAMAGE IS NOT COVERED BY WARRANTY.

If you must store your pressure washer in a location where the temperature is below 32° F, you can minimize the chance of damage to your machine by draining your machine as follows:

1. Stop the pressure washer and detach supply hose and high pressure hose. Squeeze the trigger of the spray gun to drain all water from the wand and hose.
2. Restart pressure washer and let it run briefly (about 5 seconds) until water no longer discharges from the high pressure outlet.

MAINTENANCE

Daily:

To ensure a problem free system, simple visual checks can be performed. Check for leaks in inlet supply, pumping system, pump to heater hose, heater, spray gun(s) and high pressure hose. Check for normal operating functions and pump oil level/condition. Check nozzle condition. If badly worn or leaking conditions are found, qualified personnel should repair or replace components with new original or equivalent manufacturers parts.

Check equipment for proper operation. Nozzle spray should be uniform in flow, angle, and pressure. Clean if nozzle is plugged and replace if worn. If a heavy pulsation in the hose or spray is observed, repair of the pumping system is required.

Weekly:

After the first week of operation, it is recommended 1 quart (1 litre) of motor oil be added to the heat exchanger tank through the 1-1/4" fill pipe. This oil creates a vapor barrier and slows evaporation of water in the tank.

Check heat exchanger water level. The level must be up to the filler pipe neck. Add water if necessary. If cold water has been added, heating may cause the expanding water to escape through the filler plug. This will stop after operating temperature has been reached.

Monthly:

Check system for operation. Automatic start/stop, hot high pressure water, and smooth operation should be noted.

Change oil in pump crankcase. Note the condition of the oil when drained. If found to be creamy, water seals in pump may have to be removed and replaced.

TROUBLESHOOTING

PROBLEM	POSSIBLE CAUSE	SOLUTION
LOW OPERATING PRESSURE	Faulty pressure gauge	Install new gauge.
	Insufficient water supply	Use larger garden hose; clean filter washer at water inlet.
	Old, worn or incorrect spray nozzle	Match nozzle number to machine and/or replace with new nozzle.
	Plumbing or hose leak	Check plumbing system for leaks. Retape leaks with teflon tape.
	Faulty or misadjusted unloader valve (where applicable)	Adjust unloader for proper pressure. Install repair kit when needed.
	Worn packing in pump	Install new packing kit.
	Fouled or dirty inlet or discharge valves in pump	Clean inlet and discharge valves.
	Worn inlet or discharge valves	Replace with valve kit.
	Leaking pressure control valve (where applicable)	Rebuild or replace as needed.
FLUCTUATING PRESSURE	Valves worn	Check and replace if necessary.
	Blockage in valve	Check and clean out if necessary.
	Pump sucking air	Check water supply and suction line for air seepage at joints.
	Worn piston packing	Check and replace if necessary.
PRESSURE LOW AFTER PERIOD OF NORMAL USE	Nozzle worn	Check and replace if necessary.
	Inlet or discharge valves blocked or worn	Check and clean or replace if necessary.
	Unloader valve seat worn	Check and replace if necessary.
PUMP NOISY	Air in suction line	Check water supply connections on suction line.
	Broken or weak inlet or discharge valve springs	Check and replace if necessary.
	Foreign matter in valves	Check and clean if necessary.
	Worn bearings	Check and replace if necessary.
PRESENCE OF WATER IN PUMP OIL	Water sprayed at machine	Change oil. Direct spray away from machine.
	High humidity in air	Check and change oil twice as often.
	Piston packing worn. Oil seal worn	Check and replace if necessary.
OIL SQUIRTS OUT OF OIL CAP ON PUMP	Pump overfilled with oil	Maintain oil level at red dot on sight glass at rear of pump or at top of notch on dipstick (where applicable).
WATER DRIPPING FROM UNDER PUMP	Piston packing worn	Check and replace if necessary.
	O-Ring plunger retainer worn	Check and replace if necessary.
	Cracked piston	Check and replace if necessary.

TROUBLESHOOTING

PROBLEM	POSSIBLE CAUSE	SOLUTION
OIL DRIPPING	Oil seal worn	Check and replace if necessary.
EXCESSIVE VIBRATION IN DELIVERY LINE	Irregular functioning of the valves	Check and replace if necessary.
SYSTEM WILL NOT START	Power, water, auto switch not on	Check and turn on.
	Motor overload tripped	Check and reset.
	Control fuse blown (2 or 3 amp)	Check and replace.
	Pressure switch faulty	Check, clean or replace.
	Timer faulty	Check and replace.
SYSTEM WILL NOT STOP	Water leak in discharge line	Repair water leak.
	Pressure switch faulty	Disconnect at timer. If unit stops, replace pressure switch.
	Timer resistor faulty	Replace timer.
SYSTEM STOPS AFTER APPROXIMATELY 10 SECONDS AND THEN RESTARTS	Faulty pressure switch	Check and replace.
	Leak in system	Fix leak.
WATER IS NOT HOT	Tank water low	Check for leaks and fill.
	Temperature or level controls faulty	Check and replace.
MOTOR "HUMS" BUT DOES NOT TURN	Electric motor single phasing	Check for blown fuse or loose power line connections.
PUMP RUNNING NORMALLY BUT LOW WATER PRESSURE	Air leak in inlet	Check water supply and possibility of air entering water connections.
	Faulty pressure unloader	"Bypass pressure unloader by wiring spray gun open. If good PSI, turn machine off and replace regulator. DO NOT RELEASE SPRAY GUN WHILE BYPASSING UNLOADER."
WATER ESCAPING FROM FILL PIPE ON HEAT EXCHANGER	Cold water added to heat exchanger	Will stop once at operating temperature.
	Ruptured coil or leaking	Check, repair or replace fittings.

TROUBLESHOOTING

PROBLEM	POSSIBLE CAUSE	SOLUTION
UNLOADER DOES NOT GO INTO BY-PASS OR WILL CYCLE ITSELF	Spray gun or hose is leaking to atmosphere	Check and repair all leaks.
	Check plunger either did not move or did not seal	"Remove discharge port. Clean and inspect the check plunger. Replace the O-ring if needed."
	Actuator O-ring failure	Remove actuator plunger assembly and inspect O-ring and back-up rings. Replace if necessary.
SPIKES TOO HIGH	Slow moving actuator; this may be caused by bad O-rings either on the plunger or inside the actuator fitting.	Remove the actuator assembly to inspect the O-ring and back-up rings. The actuator assembly will have to be disassembled to inspect and/or replace the O-rings in the actuator fitting.
	Spring tension	Adjustment should stop when pressure is no longer affected by further compression of the spring.
	Hose length	Hose length can affect the amount of spike pressure. Long lengths of hose may cause high spike pressures.
SYSTEM WON'T COME UP TO PRESSURE	Water is leaking between ball and seat	Disassemble inlet fitting and check for contaminants or worn parts. Clean or replace as needed.
	O-Rings on actuator plunger are bad	Remove actuator assembly and inspect O-ring and back-up rings. Replace if necessary.
	Locknut may be improperly set	"Readjust locknut. NOTE: The locknut is inside the spring on models that have the stem exposed above the spring."
	Tip/GPM combination is incorrect	Check actual GPM on unrestricted pump and size tip accordingly.
	Tip worn- the GPM may be greater than expected with a worn tip	Replace tip.
	Bad gauge - the pressure may be higher than the gauge shows	Replace gauge.

If you need **SERVICE** on your pressure washer, contact your local Hotsy dealer or visit www.Hotsy.com. Smart phone users scan the code below to link directly to the Service Request page.



To **REGISTER** your pressure washer, please visit our Warranty Registration page at www.hotsy.com/WarrantyRegistration.aspx or scan the code below with your smart phone.

