

**Hotsy 1200 Series  
Hot Water - Gas Engine - Oil Fired**

**Operator's Manual**

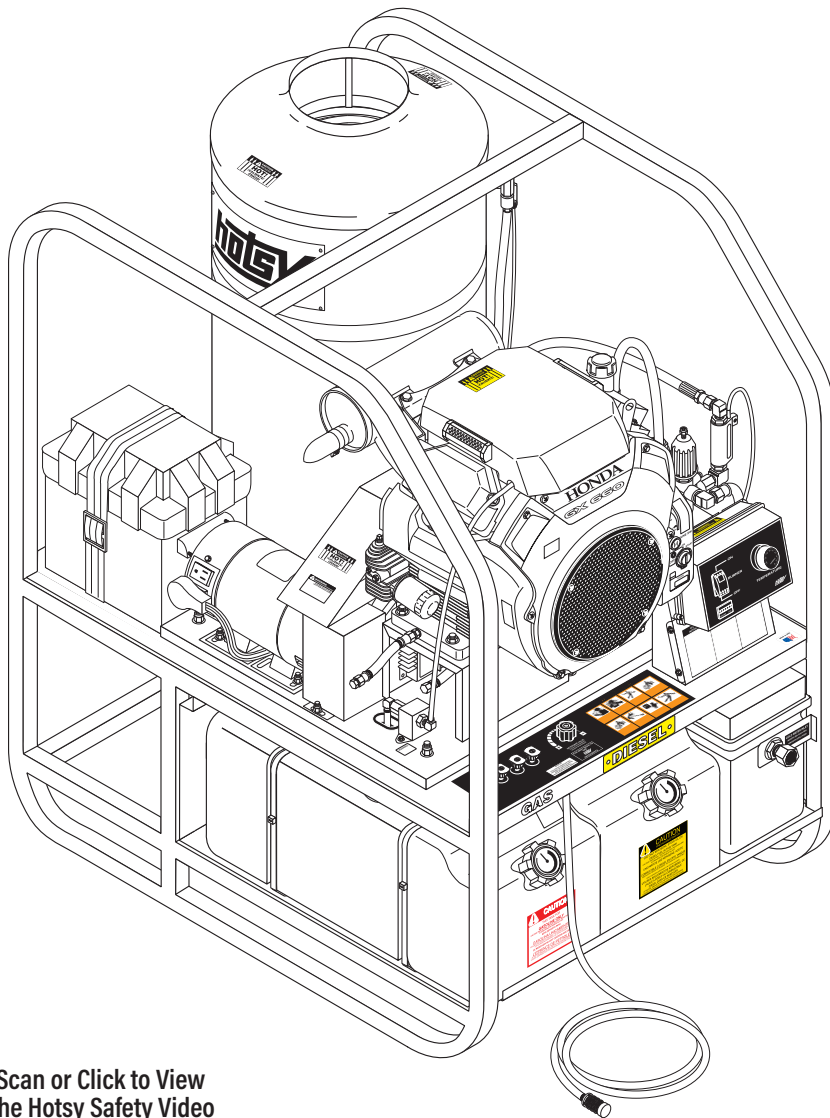

**Pressure Washer**



Scan or Click to View  
The Hotsy Safety Video



For the Hotsy Dealer nearest you,  
consult our web page at  
[www.hotsy.com](http://www.hotsy.com)



Intertek

8.914-366.0-CV 06/10/25

**MODELS:**

1260SS  
**1.110-533.0**

1270SSG-PR  
**1.110-079.0**

1270SS  
**1.110-557.0**

1260SSK  
**1.110-091.0**

1280SS  
**1.110-558.0**

1270SSK  
**1.110-092.0**

1260SSG  
**1.110-535.0**

1280SSK  
**1.110-108.0**

1270SSG  
**1.110-536.0**

1260SSGK  
**1.110-093.0**

1280SSG  
**1.110-537.0**

1270SSGK  
**1.110-107.0**

1285SS  
**1.110-043.0**

1280SSGK  
**1.110-109.0**

1290SS  
**1.110-538.0**

1290SSK  
**1.110-110.0**

1285SSG  
**1.110-044.0**

1290SSGK  
**1.110-111.0**

1290SSG  
**1.110-539.0**

1291SSK  
**1.110-112.0**

1291SS  
**1.110-075.0**

1291SSGK  
**1.110-113.0**

1291SSG  
**1.110-076.0**

---

## MACHINE DATA LABEL

---

Model: \_\_\_\_\_

Date of Purchase: \_\_\_\_\_

Serial Number: \_\_\_\_\_

Dealer: \_\_\_\_\_

Address: \_\_\_\_\_

Phone Number: \_\_\_\_\_

Sales Representative: \_\_\_\_\_

# CONTENTS

---

- MACHINE DATA LABEL .....3**
- HOW TO USE THIS MANUAL.....5**
- SAFETY .....6**
  - Important Safety Information .....6
  - Introduction & Safety Information .....6
- OPERATIONS .....10**
  - Technical Specification .....10
  - Technical Specification .....11
  - Component Identification.....12
  - Assembly Instructions.....13
  - Installation .....13
  - Operation Instructions .....16
  - Storage .....18
- MAINTENANCE .....19**
  - Technical Specification .....20
  - Wiring Diagram - 1270/80/90/91SSG, .....23
  - Wiring Diagram - 1260/85SSG, 1260/70/80/90/91SSGK.....24
  - Wiring Diagram - 1260/85SS, 1260/70/80/90/91SSK.....25
  - Wiring Diagram - 1270/80/91SS, 1270SSG-PR .....26
  - DC Burner Wiring Diagram - 1270/80/91SS, 1270SSG-PR .....27
  - Wire Routing.....28

---

## HOW TO USE THIS MANUAL

---

This manual contains the following sections:

- How to Use This Manual
- Safety
- Operations
- Maintenance
- Parts List

The HOW TO USE THIS MANUAL section will tell you how to find important information for ordering correct repair parts.

Parts may be ordered from authorized dealers. When placing an order for parts, the machine model and machine serial number are important. Refer to the MACHINE DATA box which is filled out during the installation of your machine. The MACHINE DATA box is located on the inside of the front cover of this manual.

Model: _____
Date of Purchase: _____
Serial Number: _____
Dealer: _____
Address: _____
Phone Number: _____
Sales Representative: _____

The model and serial number of your machine is located on the back of the machine.

The SAFETY section contains important information regarding hazardous or unsafe practices of the machine. Levels of hazards are identified that could result in product damage, personal injury, or severe injury resulting in death.

The OPERATIONS section is to familiarize the operator with the operation and function of the machine.

The MAINTENANCE section contains preventive maintenance to keep the machine and its components in good working condition. They are listed in this general order:

- Pump
- Burner Fuel Filter
- Heating Coil
- Engine
- Oil Burner Blower Motor
- Battery
- Troubleshooting

The PARTS LIST section contains assembled parts illustrations and corresponding parts list. The parts lists include a number of columns of information:

- **REF** – column refers to the reference number on the parts illustration.
- **PART NO.** – column lists the part number for the part.
- **QTY** – column lists the quantity of the part used in that area of the machine.
- **DESCRIPTION** – column is a brief description of the part.
- **NOTES** – column for information not noted by the other columns.

**NOTE: If a service or option kit is installed on your machine, be sure to keep the KIT INSTRUCTIONS which came with the kit. It contains replacement parts numbers needed for ordering future parts.**

**NOTE: The manual part number is located on the lower right corner of the front cover.**

# SAFETY

## Introduction & Safety Information

Thank you for purchasing this Pressure Washer. We reserve the right to make changes at any time without incurring any obligation.

### Owner/User Responsibility:

The owner and/or user must have an understanding of the manufacturer's operating instructions and warnings before using this pressure washer. Warning information should be emphasized and understood. If the operator is not fluent in English, the manufacturer's instructions and warnings shall be read to and discussed with the operator in the operator's native language by the purchaser/owner, making sure that the operator comprehends its contents.

Owner and/or user must study and maintain for future reference the manufacturers' instructions.

The operator must know how to stop the machine quickly and understand the operation of all controls. Never permit anyone to operate the engine without proper instructions.

### SAVE THESE INSTRUCTIONS

This manual should be considered a permanent part of the machine and should remain with it if machine is resold.

When ordering parts, please specify model and serial number. Use only identical replacement parts.

**This machine is to be used only by trained operators.**

**Danger:** This pressure washer is classified for "Outdoor Use Only - Store Indoors". Running this product indoors can result in death due to carbon monoxide, a poisonous gas you cannot see or smell. Never operate indoors, even if windows and doors are open. Only use outdoor and far away from windows, doors, and openings or vents.

## Important Safety Information

**WARNING:** If you do not follow these instructions exactly, a fire or explosion may result, causing property damage, personal injury or loss of life.

**AVERTISSEMENT:** Si ces directives ne sont pas suivies à la lettre, un incendie ou une explosion pourrait survenir et entraîner des dommages à la propriété, des lésions corporelles ou la mort.



**WARNING:** To reduce the risk of injury, read operating instructions carefully before using.

**AVERTISSEMENT:** Pour réduire le risque de blessures, lire attentivement les instructions de fonctionnement avant l'utilisation.

1. Read owner's manual thoroughly. Failure to follow instructions could cause malfunction of the machine and result in death, serious bodily injury and/or property damage.
2. Know how to stop the machine and bleed pressure quickly. Be thoroughly familiar with the controls.
3. Stay alert — watch what you are doing.



**DANGER:** Keep wand, hose, and water spray away from electric wiring or fatal electric shock may result.

**DANGER:** Garder la lance, le boyau et le jet d'eau à l'écart de tout câblage électrique ou des chocs électriques mortels pourraient survenir.

4. All installations must comply with local codes. Contact your electrician, plumber, utility company or the selling dealer for specific details.



**WARNING:** This machine exceeds 85 db appropriate ear protection must be worn.

**AVERTISSEMENT:** Cette machine excède 85 dB et une protection de l'ouïe appropriée doit être portée.

**WARNING:** High pressure spray can cause paint chips or other particles to become airborne and fly at high speeds. To

## SAFETY

avoid personal injury, eye, hand and foot safety devices must be worn.

**AVERTISSEMENT:** Un jet haute pression peut écailler la peinture ou provoquer l'émission d'autres particules dans l'air et leur projection à hautes vitesses. Pour éviter les lésions corporelles, une protection des yeux, du visage, des mains et des pieds doit être portée lors de l'utilisation de cet équipement.

5. Wear properly rated eye protection such as safety goggles or face shield while spraying. (Safety glasses do not provide full protection)
6. Keep operating area clear of all persons.



**WARNING:** Flammable liquids can create fumes which can ignite, causing property damage or severe injury.

**AVERTISSEMENT:** Des liquides inflammables peuvent produire des vapeurs qui peuvent s'enflammer, causant ainsi des dommages à la propriété ou des

blessures graves.

**WARNING:** Risk of explosion —Do not Spray flammable liquids. Operate only where open flame or torch is permitted.

**AVERTISSEMENT:** Risque d'explosion - Ne pas pulvériser de liquides inflammables. Utiliser uniquement dans des endroits où l'utilisation d'une flamme nue ou d'une torche est permise.



**WARNING:** Risk of fire — Do not add fuel when the product is operating or still hot.

**AVERTISSEMENT:** Risque d'incendie - Ne pas ajouter de carburant pendant que la machine fonctionne ou est encore chaude.

**WARNING:** Do not use gasoline crankcase draining or oil containing gasoline, solvents or alcohol. Doing so will result in fire and/or explosion.

**AVERTISSEMENT:** Ne pas utiliser d'essence, de drainage du carter de moteur ou d'essence contenant de l'huile, de solvants ou de l'alcool. Ne pas tenter de faire évaporer les résidus inflammables de toute sorte, c.-à-d. ne pas traiter les solvants, les huiles pures, etc. Agir de la sorte risquerait de créer un incendie et/ou une explosion.

7. Allow engine to cool for 1-2 minutes before refueling. If any fuel is spilled, make sure the area is dry before testing the spark plug or starting the engine. (Fire and/or explosion may occur if this is not done.)

Gasoline engines on mobile or portable equipment shall be refueled:

- a. outdoors;
- b. with the engine on the equipment stopped;
- c. with no source of ignition within 10 feet of the dispensing point; and

with an allowance made for expansion of the fuel should the equipment be exposed to a higher ambient temperature. In an overfilling situation, additional precautions are necessary to ensure that the situation is handled in a safe manner.

**WARNING:** Risk of injury. Disconnect battery ground terminal before servicing.

**AVERTISSEMENT:** Risque de blessures. Débrancher la borne de mise à la terre de la batterie avant de procéder à des opérations d'entretien.

8. When in use, do not place machine near flammable objects as the engine is hot.
9. Oil burning appliances shall be installed only in locations where combustible dusts and flammable gases or vapors are not present. Do not store or use gasoline near this machine.
10. Use No. 1 or No. 2 heating oil (ASTM D306) only. NEVER use gasoline in your fuel oil tank. Gasoline is more combustible than fuel oil and could result in a serious explosion. NEVER use crankcase or waste oil in your burner. Fuel unit malfunction could result from contamination.

Do not confuse gasoline and fuel oil tanks. Keep proper fuel in proper tank.

# SAFETY



**WARNING:** Risk of injury. Hot surfaces can cause burns. Use only designated gripping areas of spray gun and wand. Do not place hands or feet on non-insulated areas of the pressure washer.

**AVERTISSEMENT:** Risque de blessures. Les surfaces

*chaudes peuvent causer des brûlures. Utiliser uniquement les zones de prise désignées du pistolet pulvérisateur et de la lance. Ne pas placer les mains ou les pieds sur des endroits non isolés de la laveuse à pression.*

11. Transport/Repair with fuel tank EMPTY or with fuel shut-off valve OFF.



**WARNING:** Hot discharge fluid. Do not touch or direct discharge stream at persons or animals.

**AVERTISSEMENT:** Liquide de décharge chaud. Ne pas diriger le débit de décharge vers des personnes ou des animaux.

**WARNING:** This machine produces hot water and must have insulated components attached to protect the operator.

**AVERTISSEMENT:** Cette machine produit de l'eau chaude et doit comporter des composants isolés attachés pour protéger l'opérateur.

12. To reduce the risk of injury, close supervision is necessary when a machine is used near children. Do not allow children to operate the pressure washer. This machine must be attended during operation.



**WARNING:** Grip cleaning wand securely with both hands before starting. Failure to do this could result in injury from a whipping wand.

**AVERTISSEMENT:** Agripper la lance de nettoyage avec les deux mains avant de commencer. Le non-respect de

*cette consigne pourrait mener à des blessures causées par le mouvement violent de la lance.*

13. Never make adjustments on machine while in operation.
14. Be certain all quick coupler fittings are secured before using pressure washer.



**WARNING:** High pressure developed by these machines will cause personal injury or equipment damage. Keep clear of nozzle. Use caution when operating. Do not direct discharge stream at people and animals, or severe injury or death will result.

**AVERTISSEMENT:** La haute pression générée par ces machines causera des lésions corporelles ou des dommages à l'équipement. Se tenir à l'écart de la buse. Faire preuve de prudence lors de l'utilisation. Ne pas décharger directement le jet vers des personnes ou des animaux, car cela risquerait de causer des blessures graves ou même la mort.



**WARNING:** Protect machine from freezing.

**AVERTISSEMENT:** Protéger la machine contre le gel.

15. To keep machine in best operating conditions, it is important you protect machine from freezing. Failure to protect machine from freezing could cause malfunction of the machine and result in death, serious bodily injury, and/or property damage. Follow storage instructions specified in this manual.
16. Inlet water must be clean fresh water and no hotter than 90°F.



**WARNING:** Risk of asphyxiation. Use this product only in a well ventilated area.

**AVERTISSEMENT:** Risque d'asphyxie - Utiliser ce produit uniquement dans un endroit bien ventilé.

Avoid installing machines in small areas or near exhaust fans. Adequate oxygen is needed for combustion or dangerous carbon monoxide will result.

## SAFETY

17. Manufacturer will not be liable for any changes made to our standard machines or any components not purchased from us.
18. The best insurance against an accident is precaution and knowledge of the machine.



**WARNING:** *Be extremely careful when using a ladder, scaffolding or any other relatively unstable location. The cleaning area should have adequate slopes and drainage to reduce the possibility of a fall due to slippery surfaces.*

**AVERTISSEMENT:** *Faire preuve d'une extrême prudence au moment d'utiliser une échelle, des échafaudages ou toute autre surface relativement instable. La zone de nettoyage doit avoir une pente et un drainage adéquats pour réduire la possibilité d'une chute due à une surface glissante.*

19. Do not allow acids, caustic or abrasive fluids to pass through the pump.
20. Never run pump dry or leave spray gun closed longer than 1-2 minutes.
21. Machines with shut-off spray gun should not be operated with the spray gun in the off position for extensive periods of time as this may cause damage to the pump.
22. Protect discharge hose from vehicle traffic and sharp objects. Inspect condition of high pressure hose before using or bodily injury may result.
23. Before disconnecting discharge hose from water outlet, turn burner off and open spray gun to allow water to cool below 100° before stopping the machine. Then open the spray gun to relieve pressure. Failure to properly cool down or maintain the heating coil may result in a steam explosion.
24. Do not overreach or stand on unstable support. Keep good footing and balance at all times.
25. Do not operate this machine when fatigued or under the influence of alcohol, prescription medications, or drugs.

In oil burning models, use only kerosene, No. 1 home heating fuel, or diesel. If diesel is used, add a soot remover to every tankful.



**WARNING:** *If connection is made to portable water supply, a back flow device must be provided.*

**AVERTISSEMENT:** *Si une connexion est établie avec un approvisionnement en eau potable, un dispositif de protection contre le retour d'eau*

*doit être fourni.*



**WARNING:** *Do not spray machine or any people, animals or electrical parts.*

**AVERTISSEMENT:** *Ne pas vaporiser sur la machine ou les gens, les animaux ou les pièces électriques.*



**Follow the maintenance instructions specified in the manual.**

# OPERATIONS

## Technical Specification

Model #	Pump Volume @ Pump Head	Pump Pressure at Pump Head	Burner Type	Burner Fuel Pressure
1260SS	4.7 GPM / 258 GPH	3500 PSI	Fuel Oiled Fired, 414,318 BTU/Hr.	160-185 PSI (145-170 PSI Post Fuel Pump)
1270SS	4.5 GPM / 270 GPH	4000 PSI	Fuel Oiled Fired, 414,318 BTU/Hr.	160-185 PSI (145-170 PSI Post Fuel Pump)
1280SS	5.2 GPM / 306 GPH	3500 PSI	Fuel Oiled Fired, 414,318 BTU/Hr.	160-185 PSI (145-170 PSI Post Fuel Pump)
1260SSG	4.7 GPM / 258 GPH	3500 PSI	Fuel Oiled Fired, 414,318 BTU/Hr	Nominal 175 PSI (160 PSI Post Fuel Pump)
1270SSG	4.5 GPM / 270 GPH	4000 PSI	Fuel Oiled Fired, 414,318 BTU/Hr.	Nominal 175 PSI (160 PSI Post Fuel Pump)
1280SSG	5.2 GPM / 306 GPH	3500 PSI	Fuel Oiled Fired, 414,318 BTU/Hr.	Nominal 175 PSI (160 PSI Post Fuel Pump)
1285SS	5.2 GPM / 306 GPH	3500 PSI	Fuel Oiled Fired, 414,318 BTU/Hr.	160-185 PSI (145-170 PSI Post Fuel Pump)
1290SS	5.6 GPM / 336 GPH	3000 PSI	Fuel Oiled Fired, 456,344 BTU/Hr.	160-185 PSI (145-170 PSI Post Fuel Pump)
1285SSG	5.2 GPM / 306 GPH	3500 PSI	Fuel Oiled Fired, 414,318 BTU/Hr.	Nominal 175 PSI (160 PSI Post Fuel Pump)
1290SSG	5.6 GPM / 336 GPH	3000 PSI	Fuel Oiled Fired, 456,344 BTU/Hr.	Nominal 175 PSI (160 PSI Post Fuel Pump)
1291SS	8.0GPM/480GPH	3000 PSI	Fuel Oiled Fired, 456,344 BTU/Hr.	160-185PSI(145-170 PSI POST FUEL PUMP)
1291SSG	8.0GPM/480GPH	3000 PSI	Fuel Oiled Fired, 456,344 BTU/Hr.	160-185PSI(145-170 PSI POST FUEL PUMP)
1270SSG-PR	4.5 GPM / 270 GPH	4000 PSI	Fuel Oiled Fired, 414,318 BTU/Hr.	160-185PSI(145-170 PSI POST FUEL PUMP)

Model #	Burner Exhaust Stack	Machine Power	Machine Weight	Shipping Weight	Machine Dimensions
1260SS	10"	Briggs Vanguard	690 Lbs	780 Lbs	L 45" X W 33" X H 52"
1270SS	10"	Honda GX630	750 Lbs	840 Lbs	L 45" X W 33" X H 52"
1280SS	10"	Honda GX630	750 Lbs	840 Lbs	L 45" X W 33" X H 52"
1260SSG	10"	Briggs Vanguard	720 Lbs	810 Lbs	L 45" X W 33" X H 52"
1270SSG	10"	Honda GX630	780 Lbs	870 Lbs	L 45" X W 33" X H 52"
1280SSG	10"	Honda GX630	780 Lbs	870 Lbs	L 45" X W 33" X H 52"
1285SS	10"	Briggs Vanguard	750 Lbs	840 Lbs	L 45" X W 33" X H 52"
1290SS	10"	Honda GX630	750 Lbs	840 Lbs	L 45" X W 33" X H 52"
1285SSG	10"	Briggs Vanguard	780 Lbs	870 Lbs	L 45" X W 33" X H 52"
1290SSG	10"	Honda GX630	780 Lbs	870 Lbs	L 45" X W 33" X H 52"
1291SS	10"	Honda GX660	750 Lbs	840 Lbs	L 45" X W 33" X H 52"
1291SSG	10"	Honda GX660	780 Lbs	870 Lbs	L 45" X W 33" X H 52"
1270SSG-PR	10"	Honda GX630	750 Lbs	840 Lbs	L 45" X W 33" X H 52"

# OPERATIONS

## Technical Specification

Model #	Pump Volume @ Pump Head	Pump Pressure at Pump Head	Burner Type	Burner Fuel Pressure
1260SSK	4.7 GPM / 258 GPH	3500 PSI	Fuel Oiled Fired, 414,318 BTU/Hr.	160-185 PSI (145-170 PSI Post Fuel Pump)
1270SSK	4.5 GPM / 270 GPH	4000 PSI	Fuel Oiled Fired, 414,318 BTU/Hr.	160-185 PSI (145-170 PSI Post Fuel Pump)
1280SSK	5.2 GPM / 306 GPH	3500 PSI	Fuel Oiled Fired, 414,318 BTU/Hr.	160-185 PSI (145-170 PSI Post Fuel Pump)
1290SSK	5.6 GPM / 336 GPH	3000 PSI	Fuel Oiled Fired, 456,344 BTU/Hr.	160-185 PSI (145-170 PSI Post Fuel Pump)
1291SSK	8.0GPM/480GPH	3000 PSI	Fuel Oiled Fired, 456,344 BTU/Hr.	160-185 PSI (145-170 PSI Post Fuel Pump)
1260SSGK	4.7 GPM / 258 GPH	3500 PSI	Fuel Oiled Fired, 414,318 BTU/Hr.	Nominal 175 PSI (160 PSI Post Fuel Pump)
1270SSGK	4.5 GPM / 270 GPH	4000 PSI	Fuel Oiled Fired, 414,318 BTU/Hr.	Nominal 175 PSI (160 PSI Post Fuel Pump)
1280SSGK	5.2 GPM / 306 GPH	3500 PSI	Fuel Oiled Fired, 456,344 BTU/Hr.	Nominal 175 PSI (160 PSI Post Fuel Pump)
1290SSGK	5.6 GPM / 336 GPH	3000 PSI	Fuel Oiled Fired, 456,344 BTU/Hr.	Nominal 175 PSI (160 PSI Post Fuel Pump)
1291SSGK	8.0GPM/480GPH	3000 PSI	Fuel Oiled Fired, 456,344 BTU/Hr.	160-185PSI (145-170 PSI Post Fuel Pump)

Model #	Burner Exhaust Stack	Machine Power	Machine Weight	Shipping Weight	Machine Dimensions
1260SSK	10"	Karcher V-Twin	690 Lbs	780 Lbs	L 45" X W 33" X H 52"
1270SSK	10"	Karcher V-Twin	750 Lbs	840 Lbs	L 45" X W 33" X H 52"
1280SSK	10"	Karcher V-Twin	750 Lbs	840 Lbs	L 45" X W 33" X H 52"
1290SSK	10"	Karcher V-Twin	750 Lbs	840 Lbs	L 45" X W 33" X H 52"
1291SSK	10"	Karcher V-Twin	750 Lbs	840 Lbs	L 45" X W 33" X H 52"
1260SSGK	10"	Karcher V-Twin	720 Lbs	810 Lbs	L 45" X W 33" X H 52"
1270SSGK	10"	Karcher V-Twin	780 Lbs	870 Lbs	L 45" X W 33" X H 52"
1280SSGK	10"	Karcher V-Twin	780 Lbs	870 Lbs	L 45" X W 33" X H 52"
1290SSGK	10"	Karcher V-Twin	780 Lbs	870 Lbs	L 45" X W 33" X H 52"
1291SSGK	10"	Karcher V-Twin	780 Lbs	870 Lbs	L 45" X W 33" X H 52"

# OPERATIONS

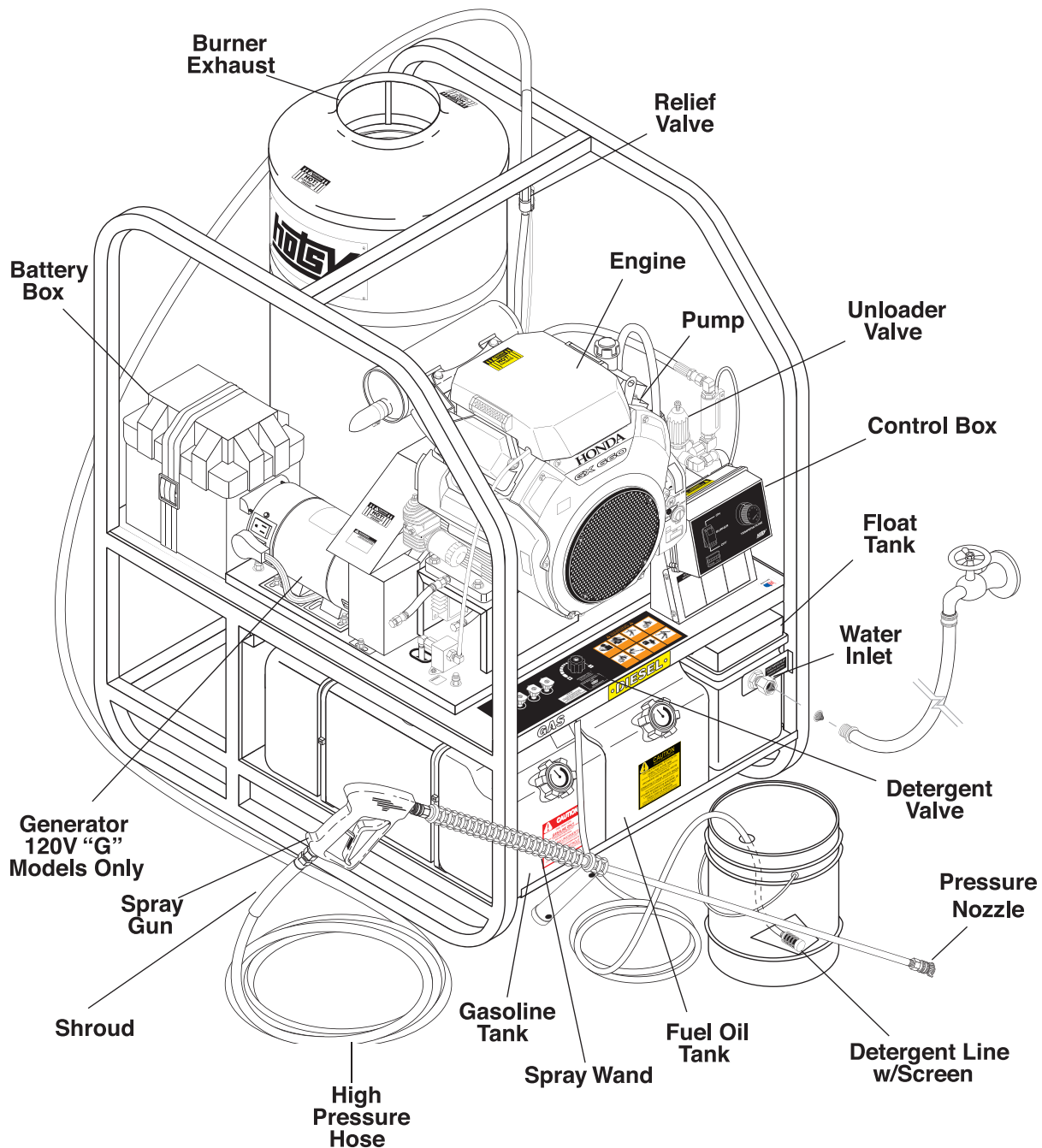

## Component Identification

**Pump** — Delivers a specific gpm to the high pressure nozzle which develops pressure.

**Spray Gun** — Controls the application of water and detergent onto cleaning surface with trigger device. Includes safety latch.

**Detergent Valve** — Allows you to siphon and mix detergents

**Wand** — Must be connected to the spray gun.

**Relief Valve** — Safety device preventing over pressurization

**High Pressure Hose** — Connect one end to water pump high pressure discharge nipple and the other end to spray gun.

**Unloader Valve** — Safety device which, when the spray gun closes, prevents over pressurization.

**Bend Restrictor (Shroud)** — This shroud has different lengths depending on pressure. The largest shroud must be connected to the spray gun to protect operator if hose becomes separated.

# OPERATIONS

## Assembly Instructions

### Unpacking

Unpack carefully. Wear safety glasses or goggles while unpacking, assembling, or operating pressure washer. If there are missing components or hidden damage, immediately contact carrier concerning discrepancies.

### Parts Included

- Pressure Washer
- Pressure Hose
- Pressure Nozzles (3 Ea.)
- Wand
- Trigger Gun
- Operations Manual
- Gasoline Engine Manual

### Pressure Hose, Trigger Gun and Wand

1. Install the pressure hose on the pressure washer as shown.

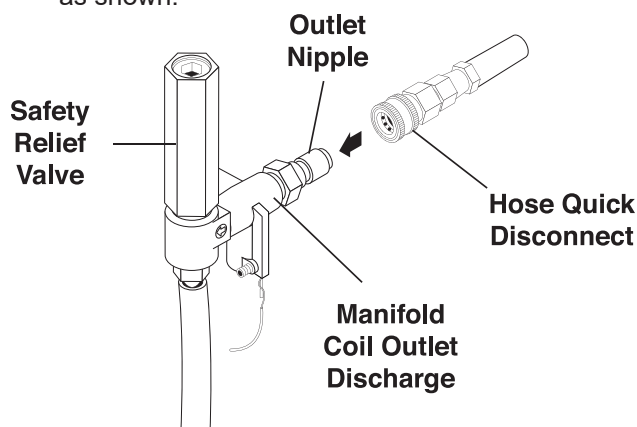

**NOTE: The pressure nozzle is not to be installed at this time.**

**NOTE: The safety Relief Valve must be inspected and tested annually.**

2. Assemble wand components as shown.

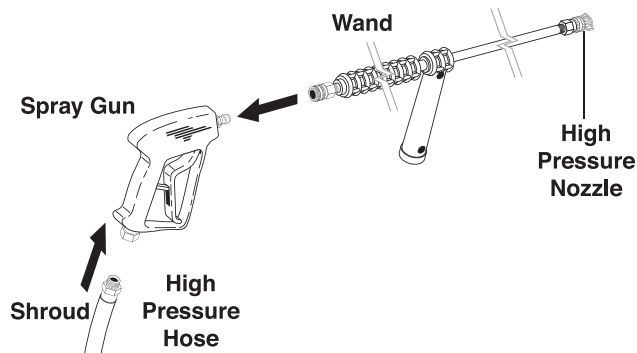

3. Make sure all connections are secure.

**NOTE: Longest hose shroud end must be connected to spray gun.**

### Installation

#### Getting Started

**IMPORTANT: Proper initial installation of equipment will assure more satisfactory performance, longer service life, and lower maintenance cost.**

**IMPORTANT: The use of backflow preventer on the water supply hose is recommended and may be required by local code.**

The pressure washer should be run on a level surface and in a protected area where it is not readily influenced by outside forces such as strong winds, freezing temperatures, rain, etc. The pressure washer should be located to assure easy access for filling fluids, adjustment and maintenance. Normal precautions should be taken by the operator to prevent moisture from reaching the pressure washer. It is recommended that a partition be made between the wash area and the pressure washer to prevent direct spray from the high-pressure wand from coming in contact with the pressure washer. Moisture reaching the pressure washer will reduce its service life. All installations should comply with the local codes covering such installations.

**IMPORTANT: DO NOT run machine indoors or in an enclosed area where high ambient temperatures exist. High ambient temperatures (above 100° F) can cause engine oil failure and will greatly reduce the engine's performance.**

# OPERATIONS

## Venting

**CAUTION:** All venting must be in accordance with applicable federal and state laws, and local ordinances. Consult local heating contractors.

**ATTENTION:** Toute la ventilation doit être conforme aux lois fédérales et de l'État ou de la province, et aux réglementations locales applicables. Consulter des entrepreneurs en systèmes de chauffage locaux.

If the pressure washer is to be used in an enclosed area, a flue must be installed to vent burner and engine exhaust to the outside atmosphere. Be sure the flue is the same size as the burner exhaust vent on the pressure washer lid. Poor draft will cause the pressure washer to soot and not operate properly. When selecting the location for installation, beware of poorly ventilated locations or areas where exhaust fans may cause an insufficient supply of oxygen. Proper combustion can only be obtained when there is a sufficient supply of oxygen available for the amount of fuel being burned. If it is necessary to install the machine in a poorly ventilated area, outside fresh air will have to be supplied to the machine. Locate the pressure washer so that the flue will be as straight as possible and protrude through the roof at a proper height and location to provide adequate draft. This oil fired pressure washer must have a draft regulator installed in the flue (available from most heating contractors). A draft regulator will permit proper upward flow of exhaust flue gases.

## Battery

**WARNING:** Batteries generate explosive gases during normal battery operation. DO NOT expose the battery to flame or sparks as these gases may ignite.

**AVERTISSEMENT:** Les batteries génèrent des gaz explosifs au cours de leur fonctionnement normal. NE PAS exposer la batterie aux flammes ou aux étincelles, car ces gaz pourraient s'enflammer.

**WARNING:** Battery fluid is highly acidic. If battery fluid contacts skin or clothing, wash immediately with soap and water. If battery fluid enters eye, immediately flood eye with running cold water for at least 15 minutes and get immediate medical attention.

**AVERTISSEMENT:** Le liquide de batterie est très acide. Si le liquide de batterie entre en contact avec la peau ou les vêtements, laver immédiatement à l'eau et au savon. Si le liquide de la batterie entre en contact avec les yeux,

*rincer immédiatement les yeux avec de l'eau froide pendant au moins 15 minutes, puis obtenir des soins médicaux immédiats.*

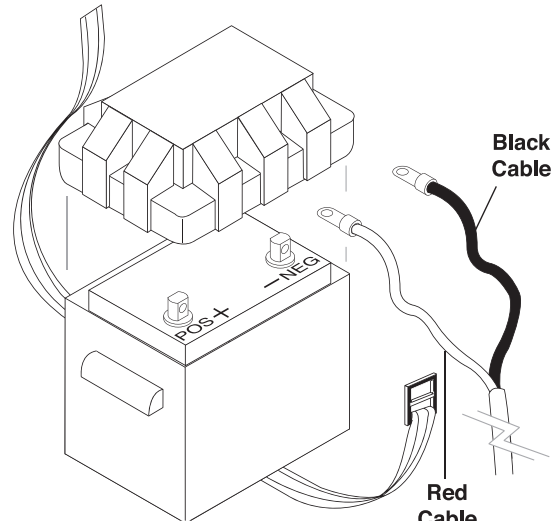

1. Install battery (battery not included) in battery box as shown. Use a standard automotive battery minimum 500 CCA (Cold Cranking Amps). It is recommended that a dual cell battery (a battery with a separate cell for emergency starting) be used.
2. To reduce the possibility of sparking attach the battery cables in the following order. First attach the positive battery cable (red) to the positive "+" terminal of the battery. Next, attach the negative battery cable (black) to the negative "-" terminal of the battery. To disconnect the battery, remove the cables in the opposite order as installed.
3. Install battery box lid and secure with strap provided.

## Oil Burner

**Burner Air Adjustment:** The oil burner on this machine is preset for operation at altitudes near 500 feet. If operated at higher altitudes, it may be necessary to adjust the air band for a #1 or #2 smoke spot on the Bacharach scale.

To adjust, Loosen locking screw found on the air band. Start machine and turn burner ON and close air band until black smoke appears from burner exhaust vent. Note air band position. Next, slowly open the air band until white smoke just starts to appear and note air band position, again. Rotate the air band halfway between to the previously noted positions. Tighten locking screws. Typical distance from the 'black smoke' position is roughly 3/8"-1/2" more open from the point of visible black smoke, but may vary based upon local operating conditions.

---

# OPERATIONS

---

- For higher altitudes, the air band opening may need to be increased; for lower altitude, the air band may need to be decreased.
- For higher humidity, the air band opening may need to be increased; for lower relative humidity, the air band may need to be decreased.
- For higher ambient temperatures the air band opening may need to be increased; for lower ambient temperatures, the air band opening may need to be decreased.

Adjust the burner to your operating location's environment as-needed for best smoke spot and performance compliant with local, state, and federal regulations.

Example: a unit preset at a factory at 1700 feet altitude with an air band of 1.1" and fuel pressure of 190 PSI with Ambient temperature of 72 °F and a relative humidity of 84% using #2 Diesel fuel oil. The unit is shipped to a location at 5300 feet altitude with ambient air temperature of 59 °F and a relative humidity of 25%. The air band required adjustment to 1.8" opening and fuel pressure lowered to 150 PSI for a high altitude adjustment for both heat input adjustments and combustion air intake with the same fuel type.

## Fuel Pressure Adjustment:

To adjust fuel pressure, First install a pressure gage into the port just after the pump fuel exit. Turn the adjusting screw (located at the regulator port) clockwise to increase, and counterclockwise to decrease. Do not exceed 200 psi or lower the pressure below 130 PSI, when checked at the post-pump pressure port.

The fuel pressure may need to be adjusted due to altitude. For every 500 ft altitude above sea level, the boiling point of water goes down 1 °F. At high altitude environments, this boiling point change may require the heat input to be lowered so the water input does not turn to steam earlier than at the factory settings and activate the pressure sensors and pressure relief equipment when the unit is operated and much higher altitudes from factory settings or local dealer site settings. Check with your dealer before making local site fuel pressure adjustments.

Also, as ambient temperature changes seasonally, the fuel temperature in the feed tank and air temperature inlet can impact fuel flow. In more extreme temperatures, this local-site adjustment may also require different fuel nozzles for fuel inlet temperatures that are at seasonal extremes

(higher or lower) in locations where the temperature changes are beyond moderate temperatures of between 40°F and 90°F. Colder temperatures will make for a thicker flow and less fine a fuel spray while hotter temperatures will make for a thinner flow a more fine spray with the same nozzle. Consider alternate nozzle configurations from the baseline factory-supplied nozzle for operating in such temperature extremes if performance is not meeting needs with air band and fuel pressure settings alone.

**NOTE: When changing fuel pump, a by-pass plug must be installed in return line port or fuel pump will not prime.**

**Caution: If white smoke appears from burner exhaust vent during start-up or operation, discontinue use and readjust air bands.**

**ATTENTION: Si de la fumée blanche s'échappe de l'évacuation du brûleur pendant le démarrage ou le fonctionnement, cesser d'utiliser et réajuster les bandes d'air.**

**NOTE: If a flue is installed, have a professional serviceman adjust your burner for a #1 or #2 smoke spot on the Bacharach scale. Gasoline Engine**

This gasoline engine is preset for operation at altitudes below 3000 feet above sea level. If operated at higher altitudes, it may be necessary to install a high altitude main jet in the carburetor. Contact an authorized engine sales and service center for details.

## Water Supply

This machine is designed to be connected to a pressurized (20 to 100 PSI) water supply, capable of maintaining a minimum of 6.0 GPM. If it is necessary to use a gravity feed water tank, the following plumbing modifications will be required.

A 1/2" NPT 3-way ball valve will need to be installed in the water inlet line. Hotsy recommends the use of Watts Regulator Valve #1/2 B6780 M1 (Hotsy P/N 921363) for this application. With this valve in place this machine will be capable of using both a pressurized or gravity feed water supply without additional modifications. For proper operation it is important that the valve be fully open for its intended supply. This will prevent air from being drawn into the system from the non active source. Also the pressure supply must still be connected to the float tank. The connection of a pressurized supply directly to the 3-way valve will prevent detergent from being drawn into the system.

# OPERATIONS

## Operation Instructions

### Before Starting

**WARNING:** Check hoses, fittings, wand, trigger gun and fuel connections daily for signs of wear, cracks and looseness, replace as required.

**AVERTISSEMENT:** Vérifier les boyaux, les raccords, le pistolet à gâchette et les connexions de carburant pour la présence de traces d'usure, de fissures et de desserrement; remplacer au besoin.

1. Read all manuals provided with this pressure washer. Become familiar with location and function of all operating and safety controls.
2. Connect the water supply hose to the float tank water inlet (standard garden hose connector). The water faucet and supply hose must be capable of providing 6.0 GPM.
3. Fill the burner fuel tank. Use kerosene, #1 grade home heating oil, #1 or #2 diesel fuel. **DO NOT USE GASOLINE.**
4. Fill the gasoline tank. Use lead free gasoline minimum 86 octane. **DO NOT** use gasoline containing more than 10% ethanol, 15% MTBE, or 5% methanol.
5. Check pump and engine oil levels.
6. If detergents are to be used, only use detergent for pressure washers. Follow instructions on detergent container.

**IMPORTANT:** Before installing the pressure nozzle on initial start-up, turn on the water supply and allow water to run from the end of the wand until clear to prevent the pressure nozzle from clogging.

**IMPORTANT:** If the pressure washer has not been used for an extended period of time, remove the pressure nozzle from the end of the wand and turn on the water supply. Allow water to run from the end of the wand until clear.

7. Install the proper pressure nozzle for your cleaning needs on end of wand.

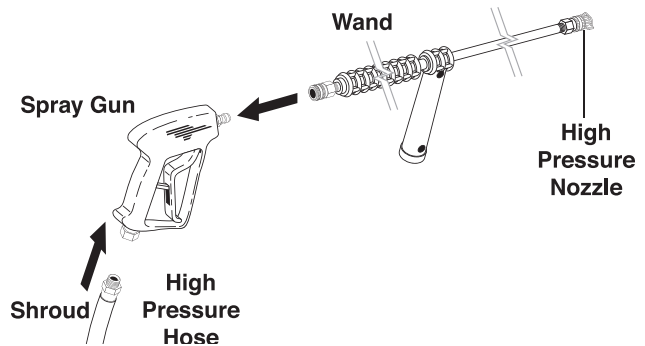

**IMPORTANT:** The trigger gun provided with this pressure washer is equipped with a manual trigger lock to prevent accidental operation of the trigger gun. The manual trigger lock should be used whenever the trigger gun is not in use.

### Fuel Pump

Some 1200 models are equipped with an electric fuel pump which operates only when the engine is running. The pump is primed when the key switch is held in the start position. In the event that the engine stalls for any reason the fuel pump will shut off.

**WARNING:** The fuel pump installed on this machine has been adjusted at the factory to provide a maximum pressure of 1.3-1.7 PSI at the pump outlet. Whenever the fuel pump is replaced the new pump must be adjusted using the following procedure:

**AVERTISSEMENT:** La pompe à carburant installée sur cette machine a été ajustée à l'usine pour fournir une pression maximale de 1,3-1,7 PSI au niveau de la sortie de la pompe. Chaque fois que la pompe à carburant est remplacée, la nouvelle pompe doit être réglée en utilisant la procédure suivante.

1. Place the ignition switch in the OFF position.
2. Disconnect the fuel line from the engine mounted fuel filter and connect a fuel pump pressure gauge (0-5 PSI) to the fuel pump discharge line.
3. Turn the ignition key to the start position and observe pressure gauge. Pressure must be set to between 1.3 and 1.7 PSI. It will be necessary to bleed off accumulated pressure in line prior to each gauge reading. Turn screw on top of fuel pump to adjust pressure (CCW to decrease, CW to increase).

## OPERATIONS

4. After adjustment, reconnect fuel line to engine mounted fuel filter and start machine. Check for fuel leakage and tighten fittings/clamps as required.

### To Start

**DANGER: DO NOT point wand or spray gun at yourself or at any person. Bodily injury may result from water under high pressure.**

**DANGER : NE PAS pointer la lance ou le pistolet pulvérisateur dans votre direction ou la direction d'une autre personne. L'eau sous haute pression peut causer des lésions corporelles.**

**IMPORTANT: The water must be turned on before starting. Running the pump dry will cause damage and void warranty.**

**IMPORTANT: DO NOT allow the machine to run with trigger gun closed for more than 3 minutes at any time or damage to pump may occur.**

1. Turn water ON.
2. Hold wand firmly with trigger gun in the closed position.
3. Turn fuel shut-off valve counterclockwise (CCW) to open. Move choke lever to full choke position. Choke may not be needed on warm engine.
4. Move throttle control to half throttle.
5. Turn key on engine clockwise (CW) hold until engine starts. DO NOT crank engine for longer than 15 seconds at any one time or starter damage may occur. If the engine does not start, it may have air in the gas lines and be unable to pull gasoline from the fuel tank. This symptom may appear if the engine has not been run recently or had been run until all gasoline was depleted from gas lines.
6. When the engine starts, move choke lever until engine runs smoothly. Then move throttle control to full throttle. When engine warms, move choke to no choke position.

**IMPORTANT: To allow for proper battery charging and AC generator operation the throttle control MUST be kept in full throttle position as soon as choke lever is placed in no choke position.**

7. Holding wand firmly, squeeze the trigger gun open. Allow air to purge from system.
8. If hot water is desired, adjust the thermostat to proper temperature. Close the trigger gun and turn burner switch ON.

**IMPORTANT: The throttle control must be in the full throttle position or damage to the AC generator or burner may result.**

Open the trigger gun. The burner will fire immediately with a puff of smoke. If smoke continues, refer to the Troubleshooting Guide in this manual. When the trigger gun is closed or the temperature setting is reached, the burner will automatically turn off.

### Detergents & General Washing Techniques



**WARNING: Some detergents may be harmful if inhaled or ingested, causing severe nausea, fainting or poisoning. The harmful elements may cause property damage or severe injury.**

**AVERTISSEMENT: Certains détergents peuvent être dangereux s'ils sont inhalés ou ingérés, provoquant de fortes nausées, des évanouissements et l'empoisonnement. Les éléments dangereux peuvent causer des dommages à la propriété ou des blessures graves.**

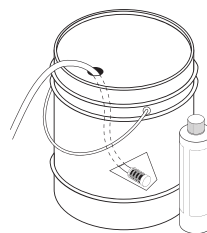

**STEP 1:** Use detergent designed specifically for pressure washers. Household detergents could damage the pump. Prepare detergent solution as required by the manufacturer. Fill a container with pressure washer detergent. Place the filter end of detergent suction tube into the detergent

container.

**STEP 2:** With the engine running, pull trigger to operate machine. Liquid detergent is drawn into the machine and mixed with water. Apply detergent to work area. Do not allow detergent to dry on surface. **IMPORTANT:** You must flush the detergent after each use by placing the suction tube into a bucket of clean water, open detergent valves then run the pressure washer for 1-2 minutes.

### Thermal Pump Protection

If you run your pressure washer for 3-5 minutes without pressing the trigger on the spray gun, circulating water in the pump can reach high temperatures. When the water reaches this temperature, the pump protector engages and cools the pump by discharging the warm water onto the ground. This thermal device prevents internal damage to the pump.

---

# OPERATIONS

---

## Cleaning Tips

Pre-rinse cleaning surface with fresh water. Place detergent suction tube directly into cleaning solution and apply to surface at low pressure (for best results, limit your work area to sections approximately 6 feet square and always apply detergent from bottom to top). Allow detergent to remain on surface 1-3 minutes. Do not allow detergent to dry on surface. If surface appears to be drying, simply wet down surface with fresh water. If needed, use brush to remove stubborn dirt. Rinse at high pressure from top to bottom in an even sweeping motion keeping the spray nozzle approximately 1 foot from cleaning surface. Use overlapping strokes as you clean and rinse any surface. For best surface cleaning action spray at a slight angle.

## Recommendations:

- Before cleaning any surface, an inconspicuous area should be cleaned to test spray pattern and distance for maximum cleaning results.
- If painted surfaces are peeling or chipping, use extreme caution as pressure washer may remove the loose paint from the surface.
- Keep the spray nozzle a safe distance from the surface you plan to clean. High pressure wash a small area, then check the surface for damage. If no damage is found, continue to pressure washing.

### **CAUTION - Never use:**

- Bleach, chlorine products and other corrosive chemicals
- Liquids containing solvents (i.e., paint thinner, gasoline, oils)
- Tri-sodium phosphate products
- Ammonia products
- Acid-based products

### **ATTENTION: Ne jamais utiliser :**

- Eau de Javel, produits à base de chlore et autres produits chimiques corrosifs
- Liquides contenant des solvants (c.-à-d. diluant à peinture, essence, huiles, etc.)
- Produits à base de tripolyphosphate de sodium
- Ammoniac ou produits à base d'acide

These chemicals will harm the machine and will damage the surface being cleaned.

## Rinsing

It will take a few seconds for the detergent to clear. Apply safety latch to spray gun and close detergent valve. Select and install the desired high pressure nozzle.

## Shutdown Instructions

1. If detergents were used, draw clear water through the system to purge detergent.
2. If burner was used, turn OFF burner switch, and allow pump to run cold water through coil.
3. Move throttle control to idle position.
4. Turn key on engine counterclockwise (CCW) to OFF position.
5. Turn OFF fuel shut-off valve.
6. Turn OFF water supply.
7. Squeeze trigger gun open to relieve system pressure.

## Storage

***DANGER: Do not store flammable liquids (gasoline, solvents, etc.) near pressure washer, or in non-ventilated areas.***

***DANGER: Ne pas entreposer de liquides inflammables (essence, mazout, pétrole, solvants, etc.) à proximité de la laveuse à pression ou dans des endroits non ventilés.***

Protect from freezing by storing in a heated area, or by flushing the system with antifreeze. To flush the system, fill the float tank with antifreeze and remove spray nozzle from wand. Start the machine and allow it to run until antifreeze flows from the end of the wand. Place end of wand into float tank and circulate the antifreeze through system for several minutes. Open and close the trigger gun several times to circulate antifreeze through the unloader valve. Place detergent line into the float tank. Open the detergent metering valve to draw antifreeze into the detergent system.

If the pressure washer is not to be used for a considerable length of time, it is recommended to flush the system with antifreeze for rust protection.

---

# MAINTENANCE

---

**WARNING:** *Unauthorized machine modification or use of non-approved replacement parts may cause personal injury and/or property damage and will void the manufacturer warranty.*

**AVERTISSEMENT:** *Une modification non autorisée de la machine ou l'utilisation de pièces de rechange non approuvées peut causer des lésions corporelles et/ou des dommages à la propriété, et annulera la garantie du fabricant.*

## Pump

Use HOTSYS Pump Oil (8.923-422.0) or equivalent 10W-40 Non-Foaming oil for pump crankcase. Crankcase must be filled to the full mark on the dipstick or to center of sight glass window found on the rear of the pump. During the break-in period, make sure the oil is changed after the first 50 hours of operation. After that, replace oil every year or 500 hours, whichever comes first.

### DO NOT:

1. Pump acids.
2. Fail to winterize in freezing temperatures.
3. Allow pump to run dry.
4. Allow machine to run with trigger gun closed for more than 3 minutes at any one time or damage to pump may occur.

### DO:

1. Use a water softener on the water system if known to be high in mineral content.
2. Use only high quality detergents and follow manufacturer's mix recommendations.
3. Immediately after using detergent solutions the system should be flushed thoroughly with clear water.
4. Clean strainer screen on detergent line periodically.

## Unloader Valve

**WARNING:** *The unloader valve on this pressure washer has been factory set and sealed and is a field nonadjustable part. Tampering with the factory setting may cause personal injury and/or property damage, and will void the manufacturer warranty.*

**AVERTISSEMENT:** *La soupape de décompression sur cette laveuse à pression a été réglée en usine, puis scellée, et est une pièce non réglable. L'altération du paramètre de l'usine pourrait causer des lésions corporelles et/ou des dommages à la propriété, et annulera la garantie du fabricant.*

## Burner Fuel Filter

Drain water that has accumulated in fuel filter and clean filter element as needed.

## Heating Coil

**Coil De scaling:** In hard water areas, scale buildup within the heating coil will occur. Scale deposits will decrease the water temperature rise and may eventually clog the heating coil. Contact your local service center when de scaling is needed.

**Coil De sooting:** Poor grades of fuel oil or inadequate combustion air will cause heavy soot buildup on the outside surface of the heating coil. This will restrict the airflow through the coil, further aggravating the soot buildup. Contact your local service center when the sooting is needed.

## Engine

Refer to engine manual provided with this pressure washer for recommended maintenance.

## Oil Burner Blower Motor

The motor bearings are permanently lubricated and will not require any additional lubrication.

## Battery

Refer to battery manufacturer's literature for recommended maintenance

# MAINTENANCE

## Technical Specification

PROBLEM	POSSIBLE CAUSE	SOLUTION
<b>ENGINE WILL NOT RUN</b>	No fuel	Replenish supply.
	Low battery	Charge battery.
	Poor battery cable connection	Clean battery terminals and check cables.
	Refer to provided engine manual for additional troubleshooting.	
<b>NO WATER FROM PRESSURE NOZZLE</b>	Pressure nozzle clogged	Clean pressure nozzle.
	Inlet water screen clogged	Clean.
	Pumping sucking air	Fill the detergent container. Check for loose hose clamps or fittings.
<b>POOR OR NO DETERGENT FLOW</b>	Low detergent level	Replenish supply.
	Detergent screen clogged	Clean.
	Detergent metering valve not opening	Check that handle or knob is not slipping on shaft.
	Pressure nozzle clogged	Clean.
<b>LOW PRESSURE FROM SPRAY NOZZLE</b>	Inlet clogged	Clean
	Spray nozzle worn or incorrect size	Replace.
	Inadequate water supply	Increase water supply.
	Pump sucking air	Fill the detergent container. Check for loose hose clamps or fittings.
<b>UNLOADER VALVE CYCLES WHEN TRIGGER GUN IS OPEN OR CLOSED</b>	Air in system	Open and close trigger gun several times.
	Defective unloader valve	Repair or replace.
	Water leak between unloader valve and trigger gun.	Check fittings, hose and trigger gun for leaks. Repair or replace.
<b>BURNER WILL NOT IGNITE WHEN TRIGGER GUN IS OPEN</b>	No fuel	Replenish supply.
	Adjustable thermostat set too low Defective pressure switch. Electrodes are dirty or out of adjustment No AC generator output.	Raise temperature setting. Repair or replace. Refer to <b>Oil Burner Manual</b> provided with machine. Check AC generator.
<b>BURNER SMOKES OR HAS OBNOXIOUS ODOR</b>	Air bands need to be adjusted Improper fuel	Readjust. Refer to Oil Burner Section under Installation. Use kerosene, #1 Grade Home Heating Oil, #1 or #2 Diesel Fuel. <b>DO NOT USE GASOLINE.</b>

## MAINTENANCE

PROBLEM	POSSIBLE CAUSE	SOLUTION
<b>MACHINE SMOKES WHILE BURNER UNIT IS RUNNING OR UNIT SMOKES AT COLD START ONLY WHEN BURNER IS OFF</b>	Improper fuel or water in fuel	Drain tank and replace contaminated fuel
	Improper air adjustment	Readjust air bands on burner assembly
	Fuel pressure is low <140 psi for burner	Adjust fuel pump pressure to specifications
	Burner nozzle is plugged or dirty	Replace nozzle. Check parts breakdown for nozzle size
	Burner nozzle spray pattern is faulty	Replace nozzle. Check parts breakdown for nozzle size
	Heavy accumulation of soot on coils and burner assembly	Remove coils and burner assembly, clean thoroughly Call local dealer
	Misaligned electrode setting	Realign electrodes to specifications
<b>MACHINE SMOKES WHILE BURNER UNIT IS RUNNING OF UNIT SMOKES AT COLD- START ONLY WHEN BURNER IS OFF CONTINUED</b>	Obstruction in smoke stack	Check for insulation blockage or other foreign objects
	Low engine RPM	Increase RPM to correct specs. See serial plate
	Fuel Pressure is too high for clean burn (fuel PSI above 140 and below 200) and smokes when burner is off	Reduce fuel pressure PSI/Increase air band set for cleaner without max water heat loss

---

## MAINTENANCE

---

### IMPORTANT

If the pressure washer demonstrates other symptoms or the corrective actions listed do not correct the problem, contact the local authorized Hotsy Service Center. The Hotsy Service Center can be identified by visiting [www.hotsy.com](http://www.hotsy.com).

**When ordering from your dealer, please provide the following:**

**Model Number:** \_\_\_\_\_

**Machine Serial Number:** \_\_\_\_\_

**Component Part Number:** \_\_\_\_\_

**Description:** \_\_\_\_\_

# WIRING DIAGRAM - 1270SSG, 1280SSG, 1290SSG, 1291SSG

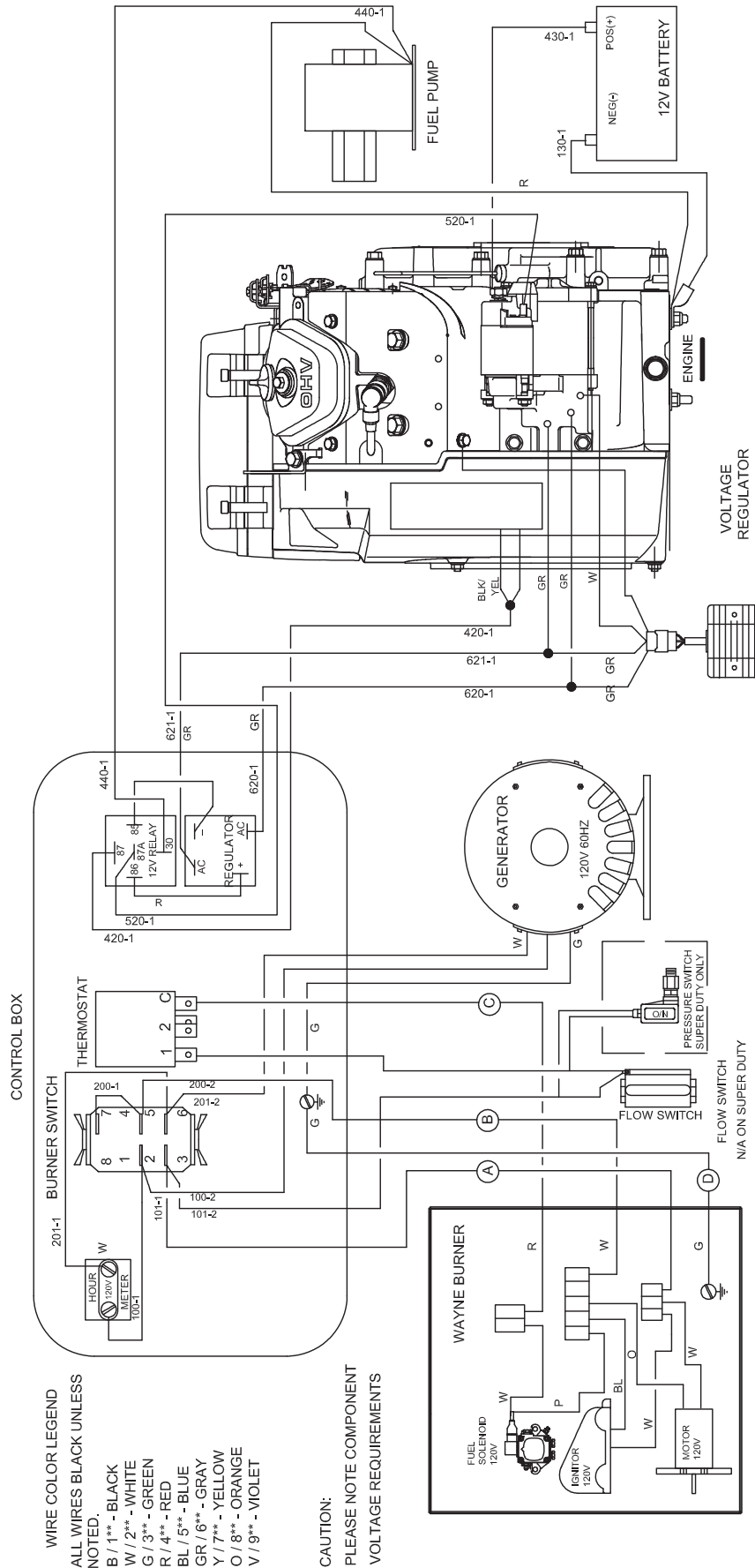



# WIRING DIAGRAM - 1260SS/SSK, 1270SSK, 1280SSK, 1285SS, 1290SSK, 1291SSK

CAUTION: PLEASE NOTE COMPONENT VOLTAGE REQUIREMENTS.

WIRE COLOR LEGEND  
ALL WIRES BLACK UNLESS NOTED

- B / 1\*\* - BLACK
- W / 2\*\* - WHITE
- G / 3\*\* - GREEN
- R / 4\*\* - RED
- BL / 5\*\* - BLUE
- GR / 6\*\* - GRAY
- Y / 7\*\* - YELLOW
- O / 8\*\* - ORANGE
- V / 9\*\* - VIOLET

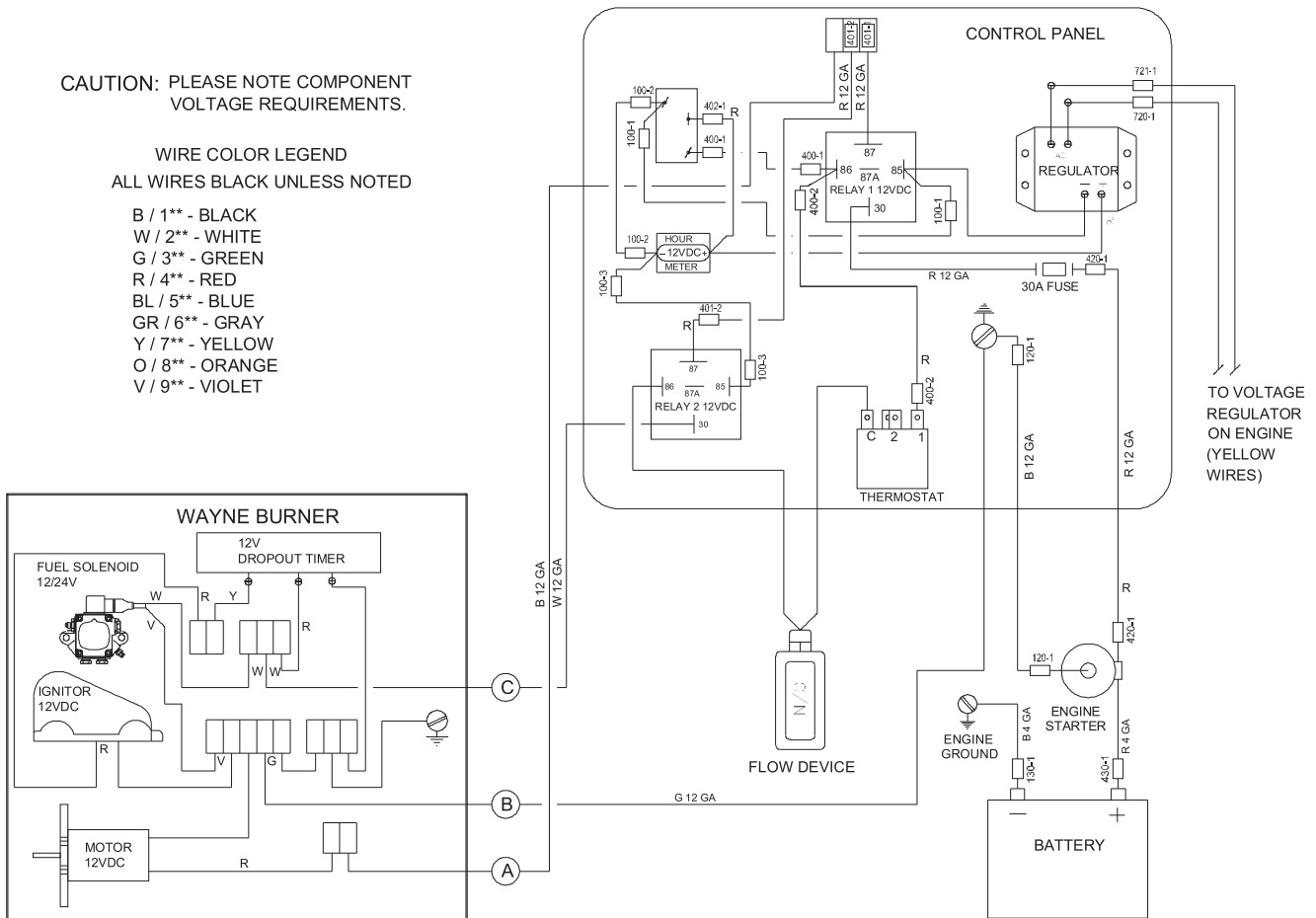

# WIRING DIAGRAM - 1270SS, 1270SSG-PR, 1280SS, 1291SS, 1291SS

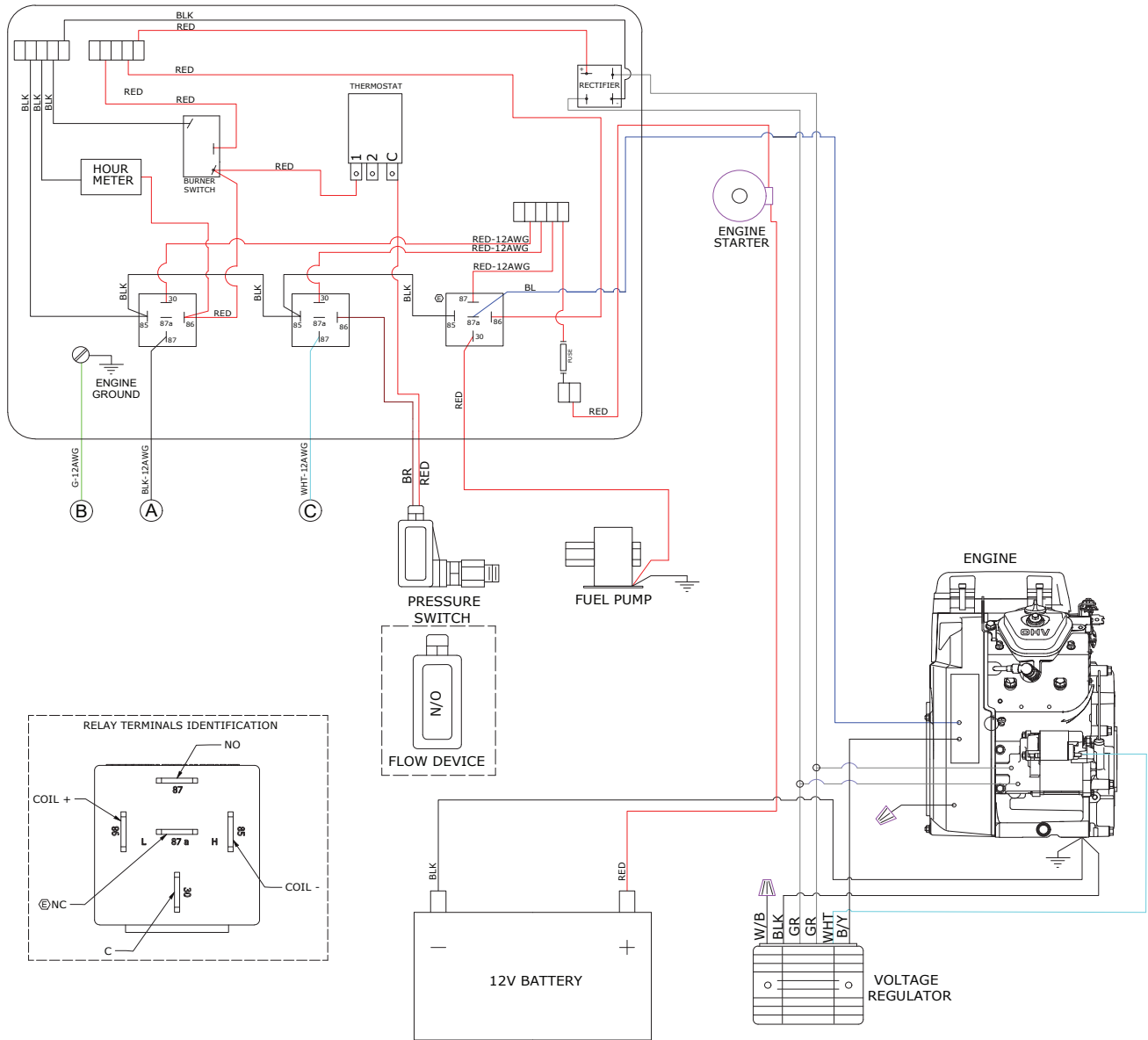

# DC BURNER WIRING DIAGRAM - 1270SS, 1270SSG-PR, 1280SS, 1291SS, 1291SS

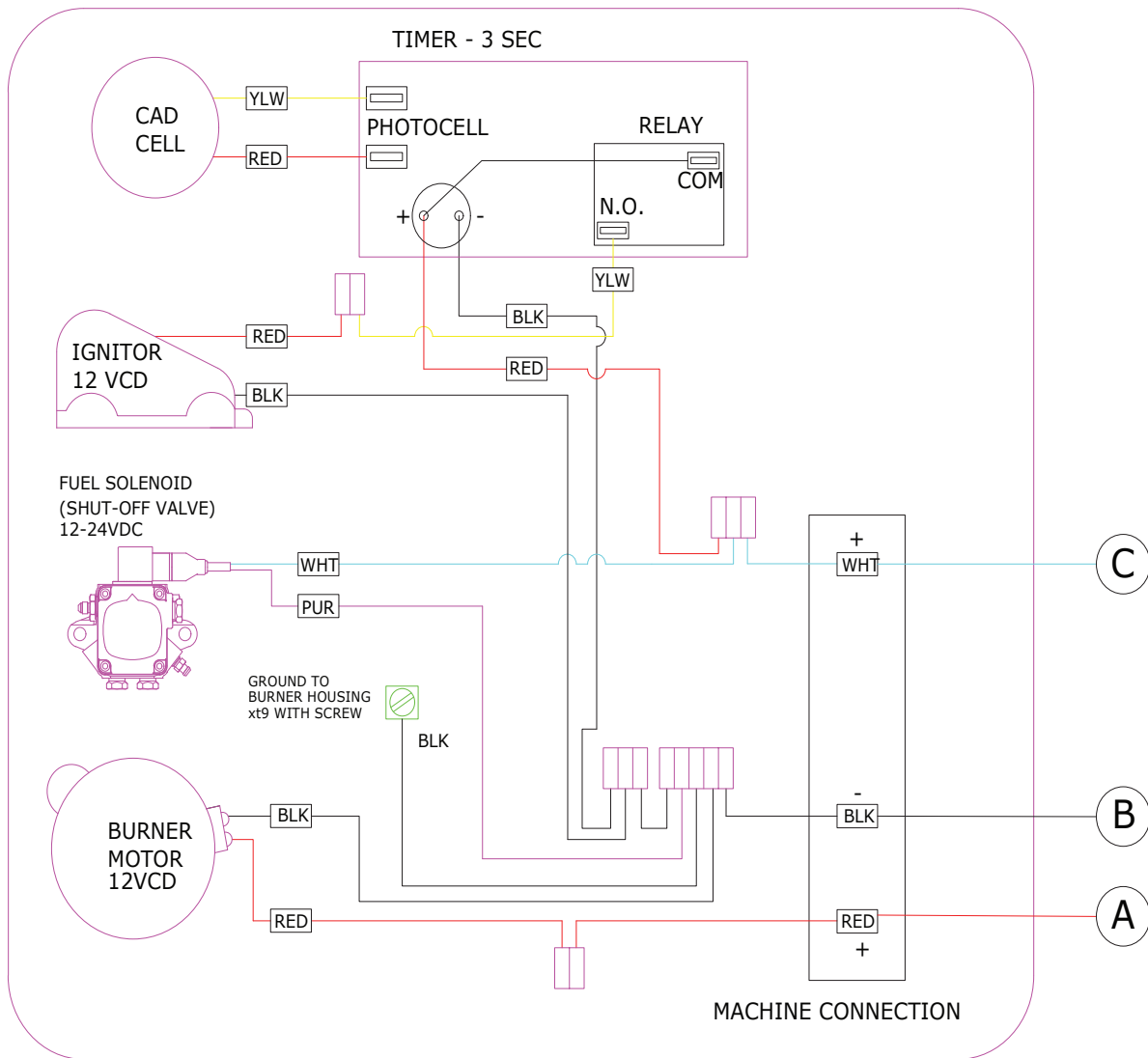

---

# WIRE ROUTING

---

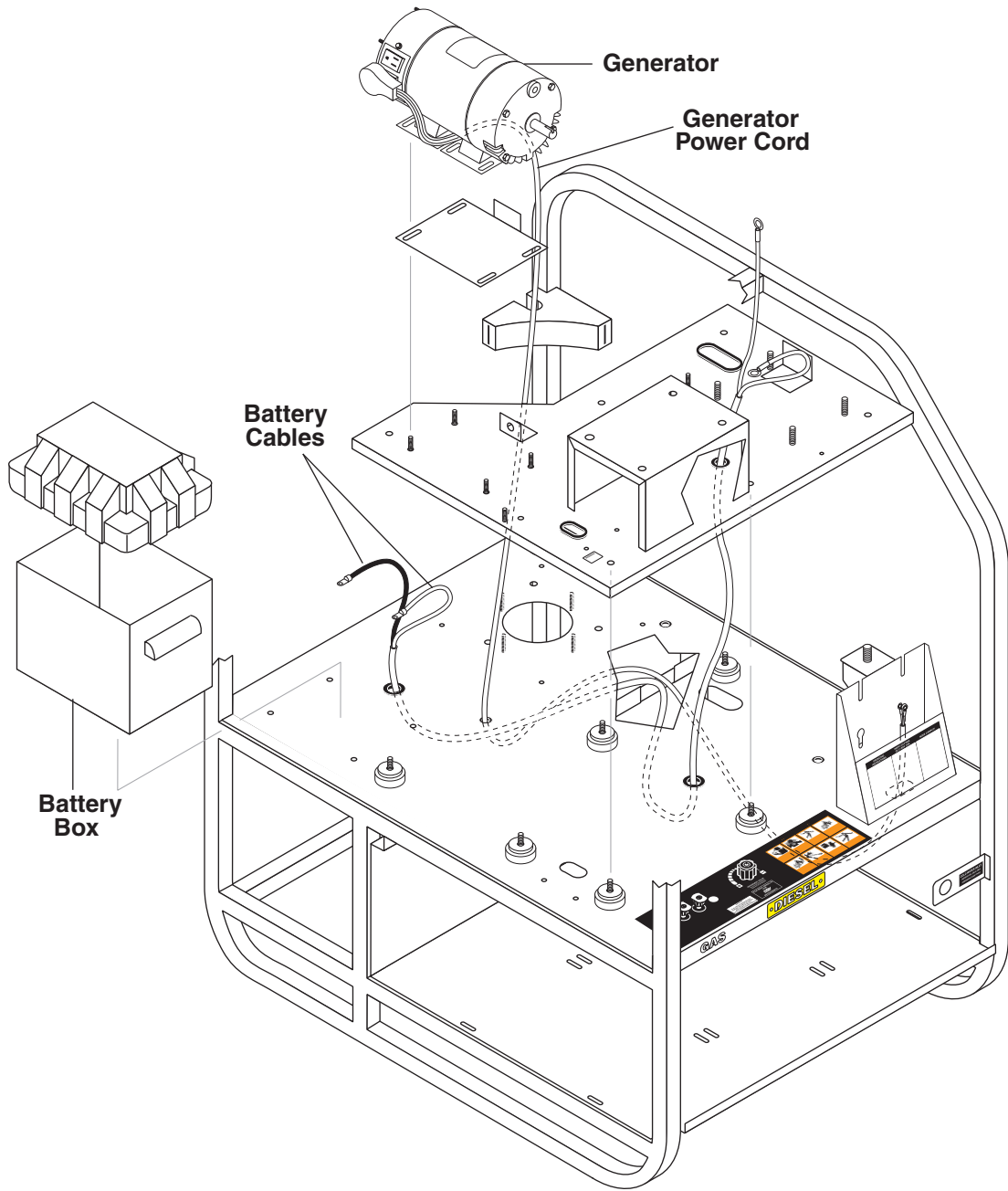

If you need **SERVICE** on your pressure washer, contact your local Hotsy dealer or visit [www.Hotsy.com](http://www.Hotsy.com). Smart phone users scan the code below to link directly to the Service Request page.



To **REGISTER** your pressure washer, please visit our Warranty Registration page at [www.hotsy.com/WarrantyRegistration.aspx](http://www.hotsy.com/WarrantyRegistration.aspx) or scan the code below with your smart phone.

