

High Pressure Cleaner
Electric Motor - Cold Water

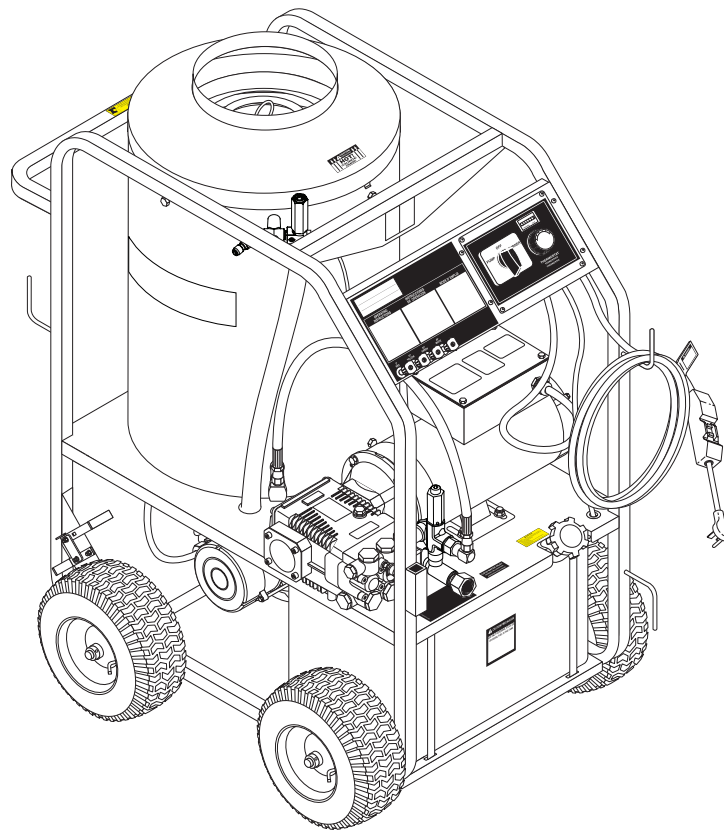

OPERATOR'S MANUAL



<u>MODEL</u>	<u>ORDER #</u>
STP-231007D	1.109-101.0
STP-201507D	1.109-102.0
STP-352007A	1.109-103.0
STP-231007D	1.109-133.0
STP-352007A	1.109-134.0

To locate your local Kärcher Commercial Pressure Washer Dealer nearest you,
visit www.karcher.com/us

CONTENTS

Introduction and Safety Information	3-5
Component Identification	6
Operating Instructions	7-8
Preventative Maintenance and Service	9-11
Exploded Views	12-13
Exploded Views Parts List	14-15
Control Panel Exploded View and Parts List	16
Hose & Spray Gun Assembly and Parts List	17
VBT Unloader Exploded View and Parts List	18
Pump Exploded View and Parts List	19-20
Burner Clear Flame Exploded View and Parts List	21-22
Troubleshooting	23
Maintenance Schedule	24

Model Number _____

Serial Number _____

Date of Purchase _____

The model and serial numbers will be found on a decal attached to the pressure washer. You should record both serial number and date of purchase and keep in a safe place for future reference.

INTRODUCTION & IMPORTANT SAFETY INFORMATION

Thank you for purchasing this Pressure Washer. We reserve the right to make changes at any time without incurring any obligation.

Owner/User Responsibility:

The owner and/or user must have an understanding of the manufacturer's operating instructions and warnings before using this pressure washer. Warning information should be emphasized and understood. If the operator is not fluent in English, the manufacturer's instructions and warnings shall be read to and discussed with the operator in the operator's native language by the purchaser/owner, making sure that the operator comprehends its contents.

Owner and/or user must study and maintain for future reference the manufacturers' instructions.

The operator must know how to stop the machine quickly and understand the operation of all controls. Never permit anyone to operate the engine without proper instructions.

SAVE THESE INSTRUCTIONS

This manual should be considered a permanent part of the machine and should remain with it if machine is resold.

When ordering parts, please specify model and serial number. Use only identical replacement parts.

This machine is to be used only by trained operators.

IMPORTANT SAFETY INFORMATION



WARNING: To reduce the risk of injury, read operating instructions carefully before using.

1. Read the owner's manual thoroughly. Failure to follow instructions could cause malfunction of the machine and result in death, serious bodily injury and/or property damage.
2. Know how to stop the machine and bleed pressure quickly. Be thoroughly familiar with the controls.
3. Stay alert — watch what you are doing.
4. All installations must comply with local codes. Contact your electrician, plumber, utility company or the selling distributor for specific details. If your machine is rated 250 volts or less, single phase will be provided with a ground fault circuit interrupter (GFCI). If rated more than 250 volts, or more than single phase this product should only be connected to a power supply receptacle protected by a GFCI.

DANGER: Improper connection of the equipment-grounding conductor can result in a risk of electrocution. Check with a qualified electrician or service personnel if you are in doubt as to whether the outlet is properly grounded. Do not modify the plug provided with the product - if it will not fit the outlet, have a proper outlet installed by a qualified electrician. Do not use any type of adaptor with this product



WARNING: Keep wand, hose, and water spray away from electric wiring or fatal electric shock may result.

5. To protect the operator from electrical shock, the machine must be electrically grounded. It is the responsibility of the owner to connect this machine

to a UL grounded receptacle of proper voltage and amperage ratings. Do not spray water on or near electrical components. Do not touch machine with wet hands or while standing in water. Always disconnect power before servicing.



WARNING: Flammable liquids can create fumes which can ignite, causing property damage or severe injury.

WARNING: Risk of explosion Operate only where open flame or torch is permitted.

6. In oil burning models, use only kerosene, No. 1 home heating fuel, or diesel. If diesel is used, add a soot remover to every tankful.

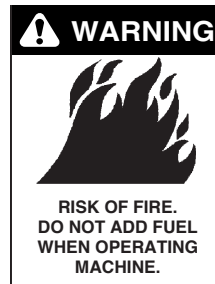

WARNING: Risk of fire — Do not add fuel when the product is operating or still hot.

WARNING: Do not use gasoline crankcase draining or oil containing gasoline, solvents or alcohol. Doing so will result in fire and/or explosion.

7. Oil burning appliances shall be installed only in locations where combustible dusts and flammable gases or vapors are not present. Do not store or use gasoline near this machine.
8. Do not allow acids, caustic or abrasive fluids to pass through the pump.
9. Never run pump dry or leave spray gun closed longer than 1-2 minutes.

IMPORTANT SAFETY INFORMATION

10. Keep operating area clear of all persons.

WARNING



USE PROTECTIVE EYE WEAR AND CLOTHING WHEN OPERATING THIS EQUIPMENT.

WARNING: High pressure spray can cause paint chips or other particles to become airborne and fly at high speeds. To avoid personal injury, eye, hand and foot safety devices must be worn.

11. Eye, hand, and foot protection must be worn when using this equipment.

WARNING



EAR PROTECTION MUST BE WORN

WARNING: This machine exceeds 85 db appropriate ear protection must be worn.

WARNING



HOT DISCHARGE FLUID: DO NOT TOUCH OR DIRECT DISCHARGE STREAM AT PERSONS.

WARNING: Hot discharge fluid. Do not touch or direct discharge stream at persons.

WARNING: This machine produces hot water and must have insulated components attached to protect the operator.

WARNING



RISK OF INJURY: HOT SURFACES CAN CAUSE BURNS

WARNING: Risk of injury. Hot surfaces can cause burns. Use only designated gripping areas of spray gun and wand. Do not place hands or feet on non-insulated areas of the pressure washer.

12. To reduce the risk of injury, close supervision is necessary when a machine is used near children. Do not allow children to operate the pressure washer. This machine must be attended during operation.

WARNING



TRIGGER GUN KICKS BACK - HOLD WITH BOTH HANDS

WARNING: Grip cleaning wand securely with both hands before starting. Failure to do this could result in injury from a whipping wand.

13. Never make adjustments on machine while in operation.

14. Be certain all quick coupler fittings are secured before using pressure washer.

WARNING



RISK OF INJECTION OR SEVERE INJURY TO PERSONS. KEEP CLEAR OF NOZZLE.

WARNING: High pressure developed by these machines will cause personal injury or equipment damage. Keep clear of nozzle. Use caution when operating. Do not direct discharge stream at people, or severe injury or death will result.

WARNING



PROTECT FROM FREEZING

WARNING: Protect machine from freezing.

15. To keep machine in best operating conditions, it is important you protect machine from freezing. Failure to protect machine from freezing could cause malfunction of the machine and result in death, serious bodily injury, and/or property damage. Follow storage instructions specified in this manual.

16. Inlet water must be clean fresh water and no hotter than 90°F.

WARNING



RISK OF ASPHYXIATION: USE THIS PRODUCT ONLY IN A WELL VENTILATED AREA.

WARNING: Risk of asphyxiation. Use this product only in a well ventilated area.

17. Avoid installing machines in small areas or near exhaust fans. Adequate oxygen is needed for combustion or dangerous carbon monoxide will result.

18. Manufacturer will not be liable for any changes made to our standard machines or any components not purchased from us.

19. The best insurance against an accident is precaution and knowledge of the machine.

WARNING



RISK OF INJURY FROM FALLS WHEN USING LADDER.

WARNING: Be extremely careful when using a ladder, scaffolding or any other relatively unstable location. The cleaning area should have adequate slopes and drainage to reduce the possibility of a fall due to slippery surfaces.

20. Do not overreach or stand on unstable support. Keep good footing and balance at all times.

21. Do not operate this machine when fatigued or under the influence of alcohol, prescription medications, or drugs.

IMPORTANT SAFETY INFORMATION

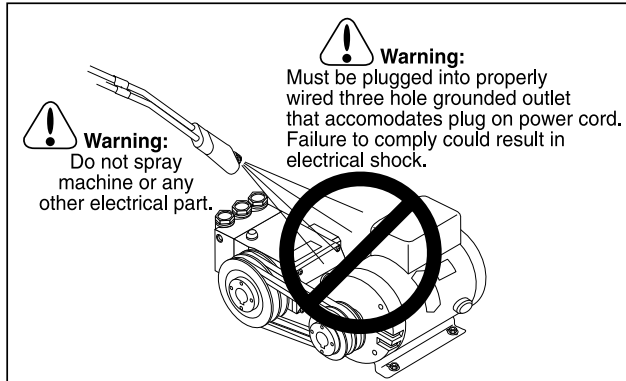

Warning:
Do not spray
machine or any
other electrical part.

Warning:
Must be plugged into properly
wired three hole grounded outlet
that accomodates plug on power cord.
Failure to comply could result in
electrical shock.



**Follow the maintenance instructions
specified in the manual.**

INSTALLATION

Place machine in a convenient location providing ample support, draining and room for maintenance.

This machine is intended for indoor use. Machine must be stored indoors when not in use.

Location:

The location should protect the machine from damaging environmental conditions, such as wind, rain, and freezing.

1. This machine should be run on a level surface where it is not readily influenced by outside sources such as strong winds, freezing temperature, rain, etc. It should be located to allow accessibility for refilling of fuel, adjustments, and maintenance. Normal precautions should be taken by the operator of the machine to prevent moisture from reaching the electrical controls.
2. It is recommended that a partition be made between the wash area and the machine to prevent water spray from coming in contact with the machine. Excess moisture reaching any electric components or electrical controls will reduce machine life and may cause electrical shorts.
3. During installation of the machine, beware of poorly ventilated locations or areas where exhaust fans may cause an insufficient supply of oxygen. Sufficient combustion can only be obtained when there is a sufficient supply of oxygen available for the amount of fuel being burned. If it is necessary to install a machine in a poorly ventilated area, outside fresh air may have to be piped to the burner and a fan installed to bring air into the machine.

Avoid small locations or areas near exhaust fans.

COMPONENT IDENTIFICATION

CAUTION HOT WATER:
Must use insulated spray gun and wand.

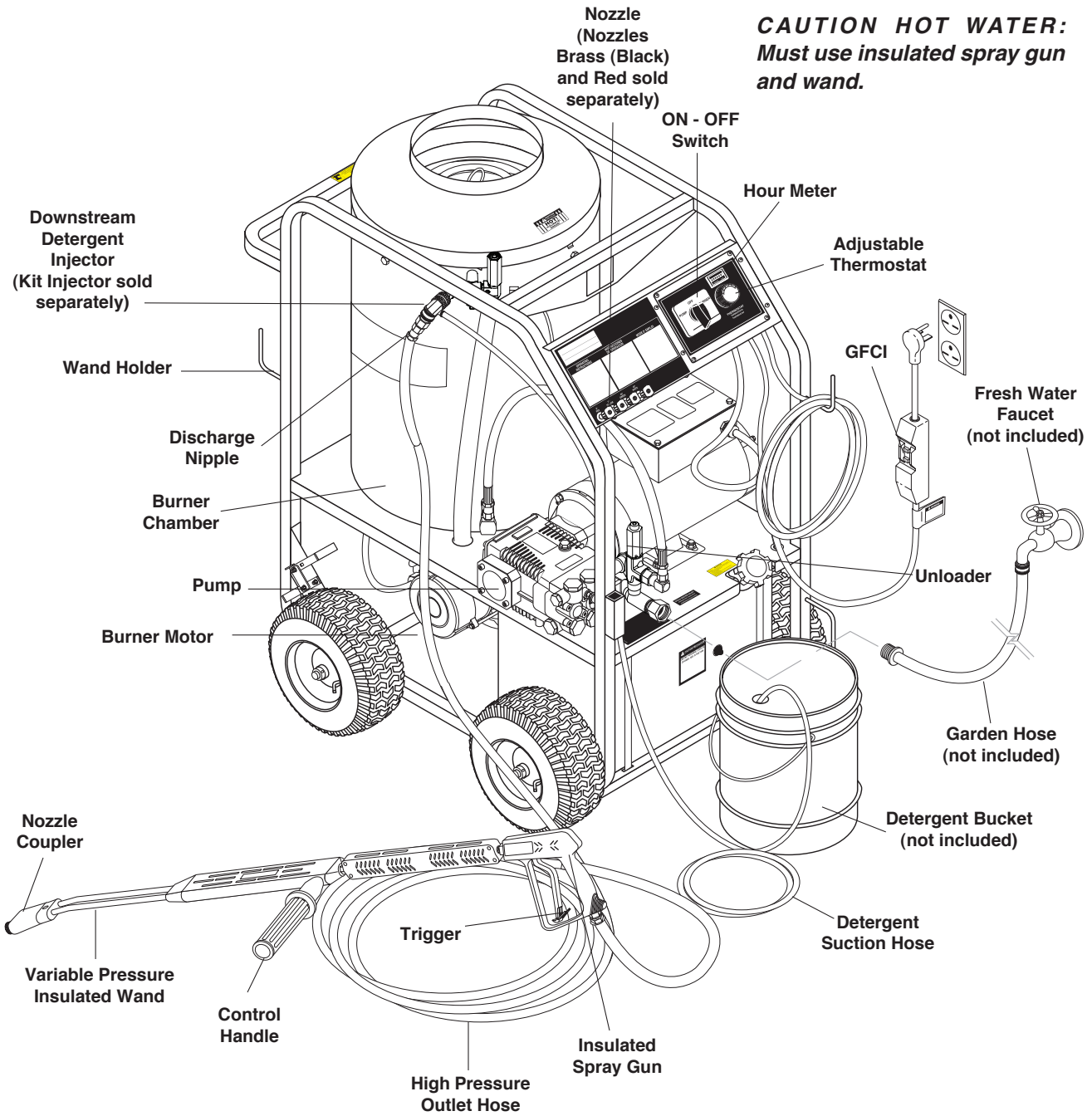

OPERATING INSTRUCTIONS

Electrical:

This machine, when installed, must be electrically grounded in accordance to local codes. Check for proper power supply using a volt meter.

Placement:

Do not locate near any combustible material. Keep all flammable material at least 20 feet away.

Allow enough space for servicing the machine.

Local code will require certain distances from floor and walls. (Two feet away from walls should be adequate.)

Water Source:

The water source for the pressure washer should be supplied by a minimum 5/8" I.D. garden hose with a city water pressure of not less than 30 PSI. If the water supply is inadequate, or if the garden hose is kinked, the attached pressure washer will run very rough and the burner will not fire.

Connection:

Connect the wand, nozzle, hose and spray gun (where applicable). On pipe thread connections, use teflon tape to avoid water leaks. (See Component Identification).

Venting:

Adding exhaust vent pipe to your oil fired burner is not recommended because restricted air flow causes carbon buildup, which affects the operation, and increases maintenance on the coil. If a stack must be used, refrain from using 90° bends. If the pipe can not go straight up then use only 45° bends and go to the next size pipe. The overall pipe length must not exceed 6 feet in length.

5. Insert quick coupler onto discharge nipple and secure by pushing quick coupler collar forward.
6. Securely attach the desired high pressure nozzle into wand coupler as described in steps 4 and 5.
7. Connect the power cord into the proper electrical outlet, then push in the GFCI reset button (Refer to serial plate for information.)
8. Grip spray gun handle securely and pull trigger. Then turn variable pressure control handle counterclockwise.
9. Turn switch to pump position. When a steady stream of water flows from the spray gun and wand, the machine is ready for cold water cleaning by turning the variable pressure control handle clockwise to raise the pressure.

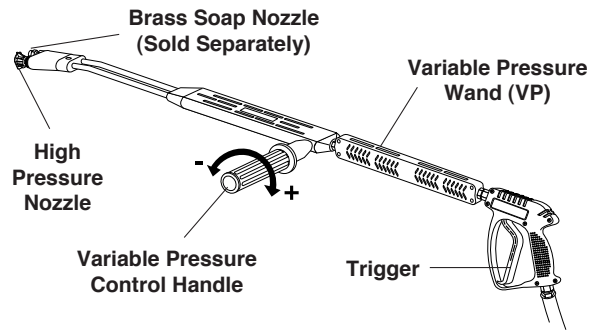

Selection of high or low pressure is accompanied by turning the handle. **Note:** High pressure nozzle must be inserted at end of wand to obtain high pressure. To apply soap read operator's manual.

10. For hot water washing, turn the switch to the burner position. (The burner will light automatically when the trigger on the spray gun is pulled.)

STARTING AND OPERATING INSTRUCTIONS

To Start:

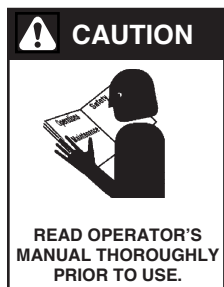

1. **STOP!** Read operator's manual before operating. Failure to read operation and warning instructions may result in personal injury or property damage.
2. Connect water supply hose and turn on water.
3. Check fuel tank and pump oil levels.
4. Connect high pressure hose to discharge nipple by sliding quick coupler collar back. (If detergent is to be applied, insert a detergent injector as shown in Component Identification).

To Stop:

1. If using the detergent injector, place the suction line in a bucket of water allowing detergent to be flushed from system.
2. Turn burner switch off and continue spraying water, allowing the water to cool.
3. After water has cooled to less than 100°F, turn the attached pressure washer off.
4. Turn garden hose water off. Open the spray gun to relieve remaining pressure.
5. Protect from freezing.

OPERATING INSTRUCTIONS

HOW TO USE THE DETERGENT INJECTOR



WARNING: *Some detergents may be harmful if inhaled or ingested causing severe nausea, fainting or poisoning. The harmful elements may cause property damage or severe injury.*

The machine can siphon and mix detergents with the use of Karcher's detergent injector kit.

1. Pull injector quick coupler collar back and secure on discharge nipple. Injector valve body arrow should point in direction of flow.
2. Connect high pressure hose to injector nipple securing quick coupler.
3. Start machine as outlined in Operating Instructions.

4. Place detergent pick-up tube into container of detergent solution.
5. Turn pressure control handle counterclockwise on the variable pressure wand. This lowers the pressure by directing the water flow through the soap nozzle and allows the detergent injector to siphon soap.
6. Open trigger spray gun. Water detergent ratio is approximately 15 to 1.
7. When you finish washing, rinse by simply turning the variable pressure wand control handle clockwise to increase pressure.

NOTE: The detergent injector will not siphon with water flowing through the high pressure nozzle at the end of the wand.

8. For clean up, place detergent pick-up tube into container of clear water and follow steps 5 and 8 to prevent detergent deposits from damaging the injector.

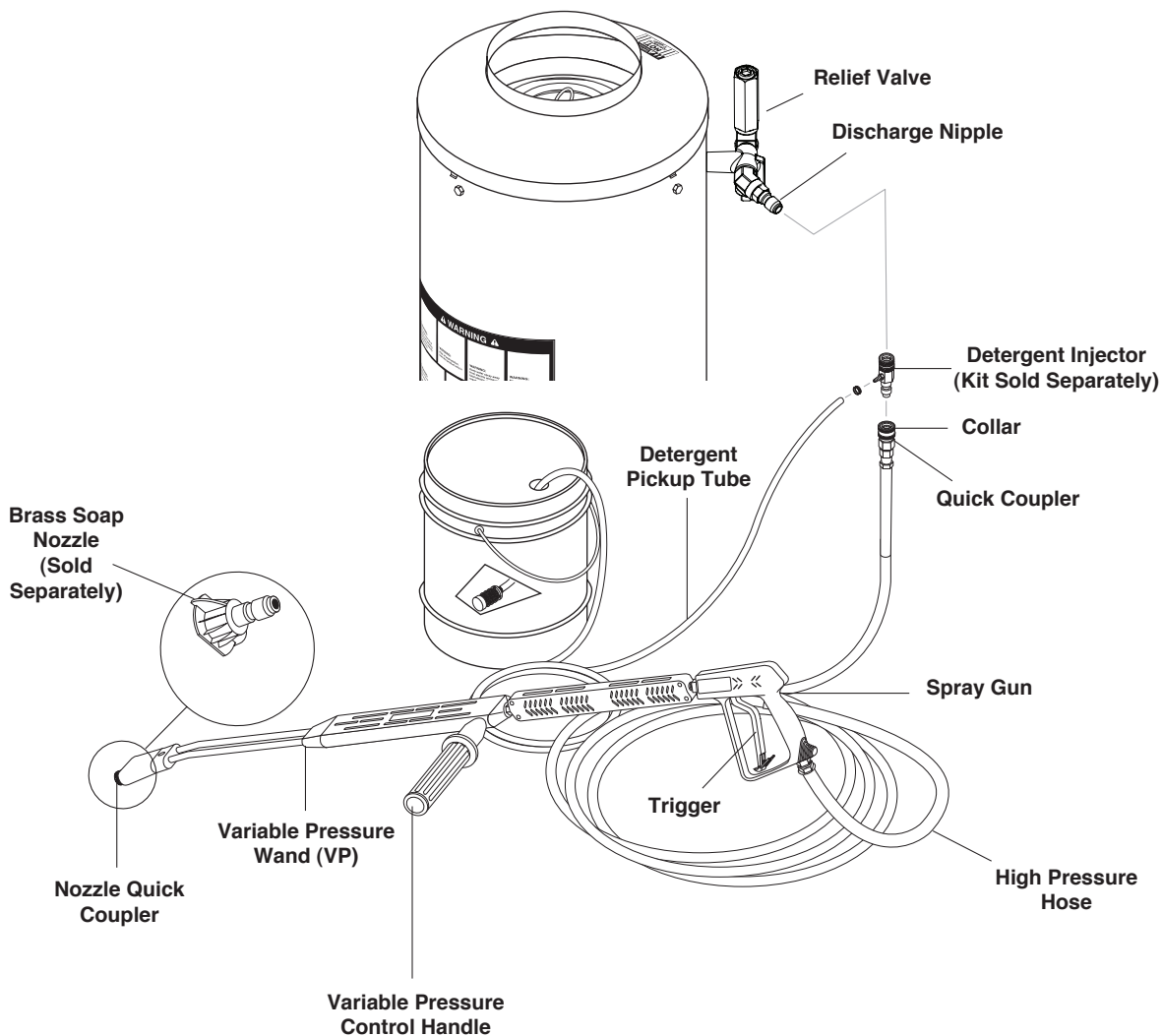

PREVENTATIVE MAINTENANCE AND SERVICE

PREVENTATIVE MAINTENANCE

1. Use clean fuel - kerosene, No. 1 home heating fuel or diesel fuel. Clean or replace fuel filter every 100 hours of operation. Avoid water contaminated fuel as it will seize up the fuel pump. De-soot coils monthly. Use an additive if diesel is being used.
2. Check to see that the attached pressure washer water pump is properly lubricated.
3. Follow Winterizing Procedures to prevent freeze damage to pump coils.
4. Always neutralize and flush detergent from system after use.
5. If water is known to be high in mineral content, use a water softener in your water system or de-scale as needed.
6. Do not allow acidic, caustic or abrasive fluids to be pumped through system.
7. Always use high grade quality cleaning products.
8. Never run pump dry for extended periods of time.
9. If machine is operated with smoking or eye burning exhaust, coils will soot up, not letting water reach maximum operating temperature. (See section on Air Adjustments.)
10. Never allow water to be sprayed on or near engine or burner assembly or any electrical component.
11. Periodically delime coils per instructions.

It is advisable, periodically, to visually inspect the burner. Check air inlet to make sure it is not clogged or blocked. Wipe off any oil spills and keep this equipment clean and dry.

The areas around the pressure washer should be kept clean and free of combustible materials, gasoline and other flammable vapors and liquids.

The flow of combustion and ventilating air to the burner must not be blocked or obstructed in any manner.

MAINTENANCE AND SERVICE

Unloader Valves:

Unloader valves are preset and tested at the factory before shipping. Occasional adjustment of the unloader may be necessary to maintain correct pressure. Call your local dealer for assistance.

Winterizing Procedure:

Damage due to freezing is not covered by warranty. Adhere to the following cold weather procedures whenever washer must be stored or operated outdoors under freezing conditions. During winter months, when temperatures drop below 32°F, protecting your machine against freezing is necessary. Store machine in a heated room. If this is not possible then mix a 50/50

solution of anti-freeze/water into a 5 gallon bucket. Place a short section of garden hose into bucket and connect it to machine. Elevate bucket and turn pump on to siphon anti-freeze through machine. If compressed air is available, an air fitting can be screwed into the inlet connector and, by injecting compressed air, all water will be blown out of system.

High Limit Hot Water Thermostat:

For safety, each machine is equipped with a high limit control switch. In the event that the temperature of the water should exceed its operating temperature, the high limit control will turn the burner off until the water cools.

Pumps:

Use only SAE 30W non-detergent oil. Change oil after the first 50 hours of use. Thereafter, change the oil every three months or at 500 hour intervals. Oil level should be checked by using the dipstick found on top of the pump or the red dot visible through the oil gauge window. Oil should be maintained at that level.

Cleaning of Coils:

In alkaline water areas, lime deposits can accumulate rapidly inside the coil pipes. This growth is increased by the extreme heat build up in the coil. The best prevention for liming conditions is to use high quality cleaning detergents. In areas where alkaline water is an extreme problem, periodic use of Deliming Powder (part #9.804-059.0) will remove lime and other deposits before coil becomes plugged. (See Deliming Instructions for use of Deliming Powder.)

Deliming Coils:

Periodic flushing of coils is recommended.

1. Fill a container or optional float tank with 4 gallons of water, then add 1 lb. of deliming powder. Mix thoroughly.
2. Remove wand assembly from spray gun and put spray gun into container. Secure the trigger on the spray gun into the open position.
3. Attach a short section (3-5 ft.) of garden hose to machine to siphon solution from an elevated container. Turn pump switch on, allowing solution to be pumped through coils back into the container. Solution should be allowed to circulate 2-4 hours.
4. After circulating solution flush entire system with fresh water. Reinstall wand assembly to spray gun.

Removal of Soot in Heating Coil:

In the heating process, fuel residue in the form of soot deposits may develop between the heating coil pipe and block air flow which will affect burner combustion. When soot has been detected on visual observation,

PREVENTATIVE MAINTENANCE AND SERVICE

The soot on the coil must be washed off after coil has been removed using the following steps:

1. Remove the tank head assembly by lifting the tank head off.
2. Remove the two pipe nipples and associated fittings.
3. Lift the coil out of the outer wrap.

CAUTION: the coil weighs about 80 lbs. Use proper lifting techniques.

4. Clean, repair and replace the coil by reversing the above steps.

Coil Reinstallation

Reinstall by reversing the above steps 4 through 1.

Fuel:

Use clean fuel oil that is not contaminated with water and debris. Replace fuel filter and drain tank every 100 hours of operation. Use Kerosene No. 1 or No. 2 Heating Fuel (ASTM D306) or diesel only. **NEVER** use gasoline in your burner tank. Gasoline is more combustible than fuel oil and could result in a serious explosion. **NEVER** use crankcase or waste oil in your burner. Fuel unit malfunction could result from contamination.

Ignition Circuit:

Periodically inspect wires, spring contact and electrodes for condition, security and proper spacing. **For transformer test (CAUTION 10,000 VOLTS)** use defect free insulated screwdriver and keep fingers off blade! Lay blade across one contact: OK if arc will span 1/2" between end of blade and other contact (see following illustration).

Electrode Setting: Beckett

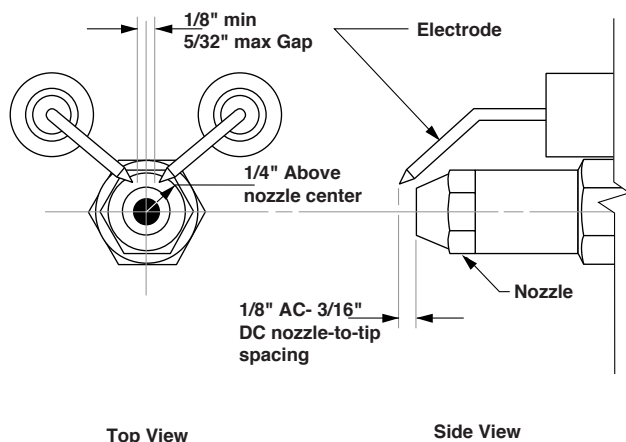

Burner Nozzle:

Keep the tip free of surface deposits by wiping it with a clean, solvent-saturated cloth, being careful not to plug or enlarge the nozzle. For maximum efficiency, replace the nozzle each season.

Fuel Control System:

The pressure washer utilizes a fuel solenoid valve located on the fuel pump to control flow of fuel to the combustion chamber. This solenoid is activated by a pressure switch located on the unloader valve. When an operator releases the trigger on the spray gun, the pressure drops, allowing the pressure switch to activate the fuel solenoid. The solenoid then closes, shutting off the supply of fuel to the combustion chamber. Controlling the flow of fuel in this way gives an instantaneous burn or no burn situation, thereby eliminating high and low water temperatures, and combustion smoke normally associated with machines incorporating a spray gun. Periodic inspection is recommended to insure that the fuel solenoid valve functions properly. This can be done by operating the machine and checking to see that when the trigger on the spray gun is in the off position, the burner is not firing.

Fuel Pressure Adjustment:

To adjust fuel pressure, turn the adjusting screw with a screwdriver (located on the fuel pump) clockwise to increase, counterclockwise to decrease. Do not exceed 200 PSI.

Wayne Burner Air Adjustment

Machines are preset and performance tested at the factory — elevation 100' above sea level. A one time correction for your location will pay off in economy, performance and extended service life. If a smoky or eye-burning exhaust is being emitted from the stack, two things should be checked.

First, check the fuel to be certain that kerosene or No. 1 home heating fuel is being used.

Next, check the air adjustment on the burner. An oily, black, smoky fire indicates a lack of air and the air band should be moved to allow the air to flow through the burner. Sharp, eye-burning fumes indicate too much air flowing through the combustion chamber. The air band should be moved to allow less air to flow through the burner.

To adjust: Start the machine and turn burner ON. Loosen the locking screws found in the air band openings (refer to illustration) and close air band until black smoke appears from burner exhaust vent. Next slowly open the air band until white smoke just starts to appear. Turn air band halfway back to the black smoke position previously noted. Tighten the locking screws.

PREVENTATIVE MAINTENANCE AND SERVICE

If the desired position cannot be obtained using only the air shutter, lock the air shutter in as close a position as can be obtained, then repeat the above procedure on the air band setting.

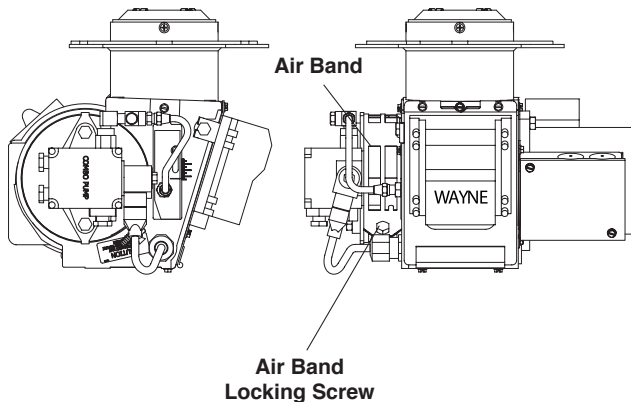

CAUTION: If white smoke appears from burner exhaust vent during start-up or operation, discontinue use and readjust air bands.

Wayne Burner Fuel Pressure Adjustment:

To adjust fuel pressure, first install a pressure gage into the port just after the pump fuel exit. Turn the adjusting screw (located at the regulator port) clockwise to increase, and counterclockwise to decrease. Do not exceed 205 psi or lower the pressure below 130 PSI, when checked at the post-pump pressure port.

The fuel pressure may need to be adjusted due to altitude. For every 500 ft altitude above sea level, the boiling point of water goes down 1 °F. At high altitude environments, this boiling point change may require the heat input to be lowered so the water input does not turn to steam earlier than at the factory settings and activate the pressure sensors and pressure relief equipment when the unit is operated and much higher altitudes from factory settings or local dealer site settings. Check with your dealer before making local site fuel pressure adjustments.

Also, as ambient temperature changes seasonally, the fuel temperature in the feed tank and air temperature inlet can impact fuel flow. In more extreme temperatures, this local-site adjustment may also require different fuel nozzles for fuel inlet temperatures that are at seasonal extremes (higher or lower) in locations where the temperature changes are beyond moderate temperatures of between 40°F and 90°F. Colder temperatures will

make for a thicker flow and less fine a fuel spray while hotter temperatures will make for a thinner flow a more fine spray with the same nozzle. Consider alternate nozzle configurations from the baseline factory-supplied nozzle for operating in such temperature extremes if performance is not meeting needs with air band and fuel pressure settings alone.

NOTE: When changing fuel pump, a by-pass plug must be installed in return line port or fuel pump will not prime.

KNA Clear Flame Oil Burner

Burner Air Adjustment: The oil burner on this machine is preset for operation at altitudes below 1000 feet. If operated at higher altitudes, it may be necessary to adjust the air band for a #1 or #2 smoke spot on the Bacharach scale.

To adjust, start machine and turn burner ON. Loosen two locking screws found on the air band and close air band until black smoke appears from burner exhaust vent. Note air band position. Next, slowly open the air band until white smoke just starts to appear. Turn air band halfway back to the previously noted position. Tighten locking screws.

Burner Air Adjustment

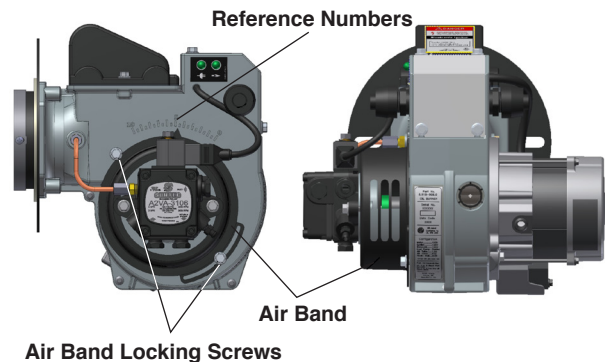

CAUTION: If white smoke appears from burner exhaust vent during start-up or operation, discontinue use and readjust air bands.

NOTE: If a flue is installed, have a professional serviceman adjust your burner for a #1 or #2 smoke spot on the Bacharach scale.

EXPLODED VIEW - LEFT

(Reversed View of Labels)

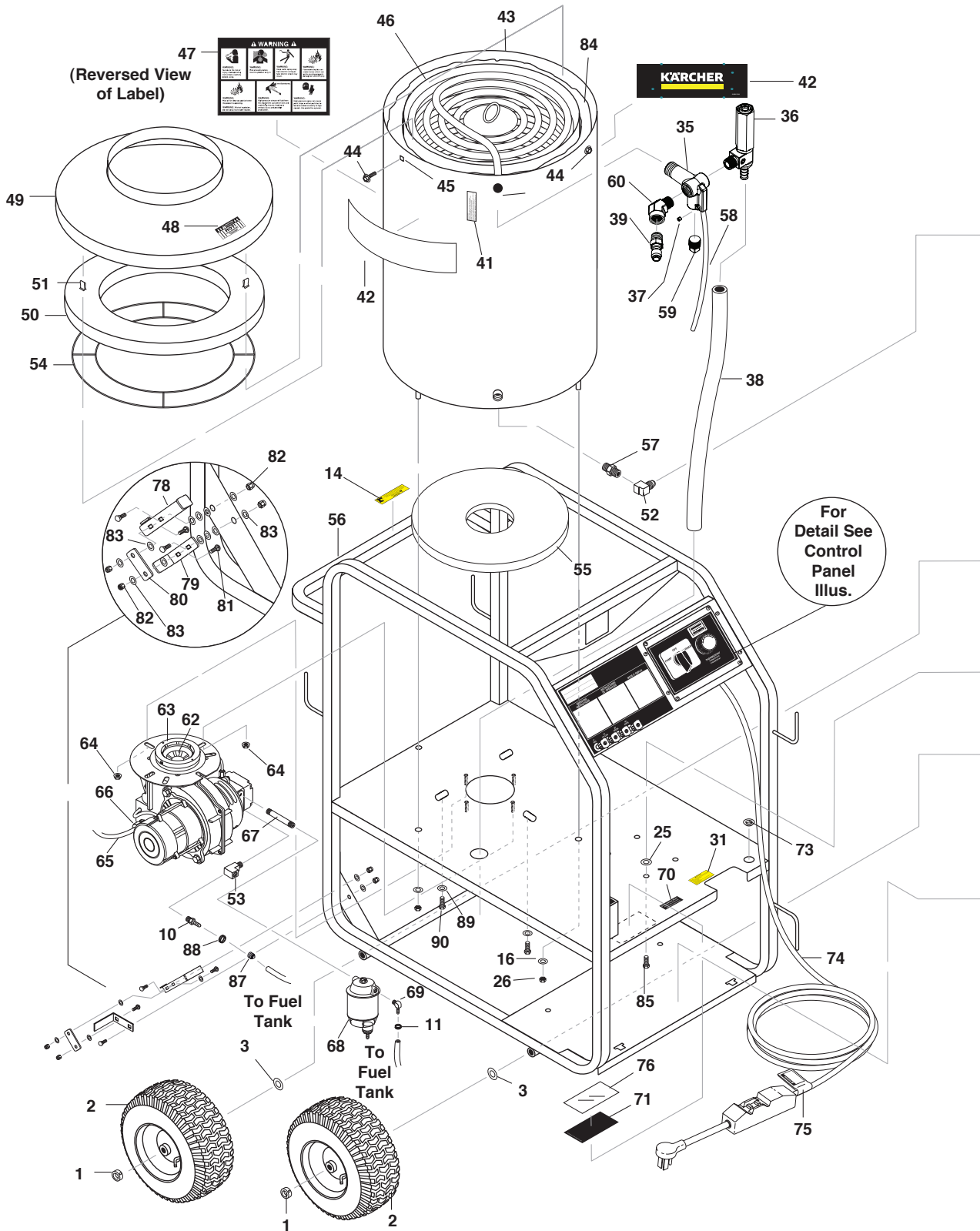

For Detail See Control Panel Illus.

EXPLODED VIEWS PARTS LIST

ITEM	PART NO.	DESCRIPTION	QTY	ITEM	PART NO.	DESCRIPTION	QTY
1	9.802-782.0	Collar, 5/8" Bore Shaft	4	30	8.754-696.0	Unloader, VBT Banjo	
2	8.754-435.0	Wheel & Pu Tire Assy, 12" Steel Rim	4		9.175-018.0	1/2M 3/8M, 3000PSI UU1 3500PSI, Universal Unloader (352007A)	1
3	9.802-810.0	Washer, 5/8", Flat, SAE	4	31	9.800-049.0	Label, Manufacturer's Cleaning Solution	1
4	8.922-672.0	Axle Long	2	33	8.918-425.0	Hose, 3/8" x 29", 2 Wire, Pressure Loop	1
5	9.802-081.0	Tank, Fuel 6 Gallon Blank	1	34	9.800-002.0	Label, Use Only Kerosene	1
6	9.802-089.0	Cap, Fuel Tank, Plastic H60-AV	1	35	9.149-003.0	Manifould Coil Outlet Dicharge	1
7	9.802-053.0	Bushing, Rubber, Nitrile	2	36	8.902-433.0	Valve Safety, Relief	1
8	9.802-141.0	Hose Barb, 1/4" Barb x 3/8" Barb, Double	1	37	9.196-012.0	Plug 10-24UNF x 1/4	1
9	9.802-177.0	Valve, 1/4" Shut-Off	1	38	8.711-785.0	Hose, 3/8" Push-On	2.75 ft.
10	9.802-138.0	Hose Barb, 1/4" Barb x 1/4" ML Pipe	1	39	9.802-171.0	Nipple, 3/8" x 3/8" NPT ST Male	1
11	6.390-126.0	Clamp, Hose, UNI .46 - .54	4	41	9.800-021.0	Label, Hot Water Outlet	1
12	9.802-254.0	Hose, 1/4" Push-On, Fuel Line	11"	42	9.800-110.0	Label, Karcher, Logo (Coil Tank)	2
13	9.802-254.0	Hose, 1/4" Push-On, Fuel Line	7"	43	8.919-733.0	Coil, Wrap, Outer, Weldement	1
14	9.800-018.0	Label, Tipover Hazard	1		8.928-430.0	Assy, Outer Wrap STP, SS (For models HDS 3.5/20 EA)	1
15	9.802-146.0	Swivel, 1/2" MP x 3/4" GHF w/Strainer	1	44	9.802-753.0	Screw, 1/4" x 3/4" HH NC, Whiz Loc	8
16	9.198-014.0	Washer 21/64 X 1"	4	45	9.802-793.0	Nut, Cage, 1/4" x 16 Gauge	4
17	9.802-039.0	Elbow, 1/2 JIC 3/8, 90° (352007A)	1	46	8.925-217.0	Spare Coil Assy Vertical Mini MTY	1
	9.802-042.0	Elbow 1/2" JIC, 3/8 Fem, 90DGR	1		8.928-428.0	Assy, Coil, STP Mty (For models HDS 3.5/20 EA)	1
18	9.804-025.0	Pump Protector, 1/4", 145°	1	47	9.800-041.0	Label, Warning, Text	1
20	9.802-720.0	Bolt, 3/8" x 1", NC HH	4	48	9.800-006.0	Label, Hot/Caliete w/Arrows Warning	1
21	9.802-814.0	Washer, 3/8" Split Ring Lock, Zinc	4	49	8.719-913.0	Top Hat, Coil	1
22	8.923-763.0	Pump, 2030S (231007D)	1	50	9.802-904.0	Insulation, Tank Head, 16" OD x 8" ID	1
	8.923-808.0	Pump 3540F (352007A)	1	51	9.802-825.0	Clip, Retaining U-Type	4
23	9.802-458.0	Switch, Pressure, N/O, 1/4" NPT SS	1	52	9.802-042.0	Elbow, 1/2" JIC x 3/8" Fem, 90°	1
24	9.804-516.0	Motor, 1.5 HP 120V 1725 RPM (231007D)	1	53	8.706-827.0	Elbow, 1/4" Street, Brass	1
	8.754-709.0	Motor, 2HP 1PH 115V 1750 RPM, 56C ODP	1	54	9.803-108.0	Retainer Ring, Insulation	1
	9.802-341.0	Motor, 5HP 1PH 230V 3450 RPM (352007A)	1	55	9.802-900.0	Insulation, Tank Bottom, 1" Blanket	1
25	8.718-980.0	Washer, 5/16" Flat	8	56	9.803-120.0	Assembly, Frame, Black	1
26	9.802-776.0	Nut, 5/16" ESNA, NC	8		8.922-545.0	Assembly, Frame (133.0 & 134.0)	1
27	9.802-427.0	Cord, Service, SOWA, 12/3 (201507D)	3 ft.	57	8.705-974.0	Nipple, 3/8" x 3/8" Hex	1
	9.802-436.0	Cord, Service, SEO, 10/3 (231007D, 352007A)	2.67 ft.	58	8.750-094.0	Thermostat, 150C/302F	1
28	8.752-969.0	Strain Relief, Small (231007D, 201507D)	1	59	8.706-241.0	Plug, 3/8, SQ head	1
	9.802-518.0	Strain Relief, STRT Lq Tite (352007A)	1	60	9.802-041.0	Elbow, 3/8", Steel, Street, 45°	1
				61	9.802-753.0	Screw, 1/4-20 x 3/4"	2

EXPLODED VIEWS PARTS LIST

ITEM	PART NO.	DESCRIPTION	QTY	ITEM	PART NO.	DESCRIPTION	QTY
62	8.756-181.0	Burner, MSR 3.75 120V 1T 120V S	1	85	9.802-709.0	Bolt, 5/16" x 3/4" NC	4
	8.756-709.0	Burner, MSR, 230V 1T 230V S (For models STP-352007A)	1	86	9.802-047.0	Adapter, 1/2" x 1/2" Pipe	1
63	8.756-861.0	Fuel nozzle, 1.10 X 80 BZ	1	87	8.754-911.0	Check Valve, 1 Way, 1/4" Barb	1
	8.754-953.0	Fuel Nozzle, 1.75 X 90AZ (For models STP-352007A)	1	88	8.750-933.0	Band Hose Clamp, Hose ID 1/8" - 5/16"	3
64	9.802-781.0	Nut, 3/8" Flange, Whiz Loc, NC	4	89	9.802-819.0	Washer, 7/16" x 2 1/2", Zinc, PG Foot	3
65	9.802-424.0	Cord, Service, SEO, 16/4, Coleman	64"	90	9.802-710.0	Screw 5/16" x 1" NC	3
66	9.802-519.0	Strain Relief, 1/2" Metal, Two Screw	1				
67	9.803-264.0	Nipple, 1/4" x 3", Black Pipe	1				
68	8.725-306.0	Filter, Parker Fuel/Oil/H2O (10 Micron), Generic	1				
69	8.706-958.0	Hose Barb, 1/4" Barb x 1/4" Pipe, 90°	1				
70	9.800-020.0	Label, Cold Water Inlet	1				
71	9.800-014.0	Label, Intended for Outdoor Use	1				
72	9.800-032.0	Label, Motor Overload Reset, Lexan	1				
73	9.802-103.0	Bushing, Snap	1				
74	9.802-432.0	GFCI, 120V 15A, w/36' 12-3 Cord (231007D)	1				
	9.802-431.0	GFCI, 120V 20A, w/36' 12-3 Cord (201507D)	1				
	9.802-430.0	GFCI, 240V 1PH 30A, w/36' 10-3 Cord (352007A)	1				
75	9.800-015.0	Label, Warning, Service Cord	1				
76	9.800-034.0	Label, Clear Lexan, 2-1/4" x 4-1/2"	1				
77	9.803-092.0	Fuel Strap Long	2				
	8.922-616.0	Fuel Strap Long (133.0, 134.0)	2				
78	9.803-111.0	Lever, Brake	1				
	8.922-518.0	Lever, Brake (133.0, 134.0)	1				
79	9.802-996.0	Bracket, Brake Pad	1				
	8.922-519.0	Bracket, Brake Pad Green (133.0, 134.0)	1				
80	9.802-997.0	Linkage, Brake	1				
	8.922-520.0	Linkage, Brake (133.0, 134.0)	1				
81	9.802-705.0	Bolt, Carriage	4				
82	9.802-773.0	Nut, 1/4" ESNA	4				
83	9.802-802.0	Washer, 1/4"	12				
84	9.802-908.0	Insulation, Blanket, 18" x 52", 1 Fiberglass	1				
	8.756-907.0	Insulation, Blanket, 19.5 X 52, Fiberglass (For models HDS 3.5/20 EA)	1				

CONTROL PANEL EXPLODED VIEW

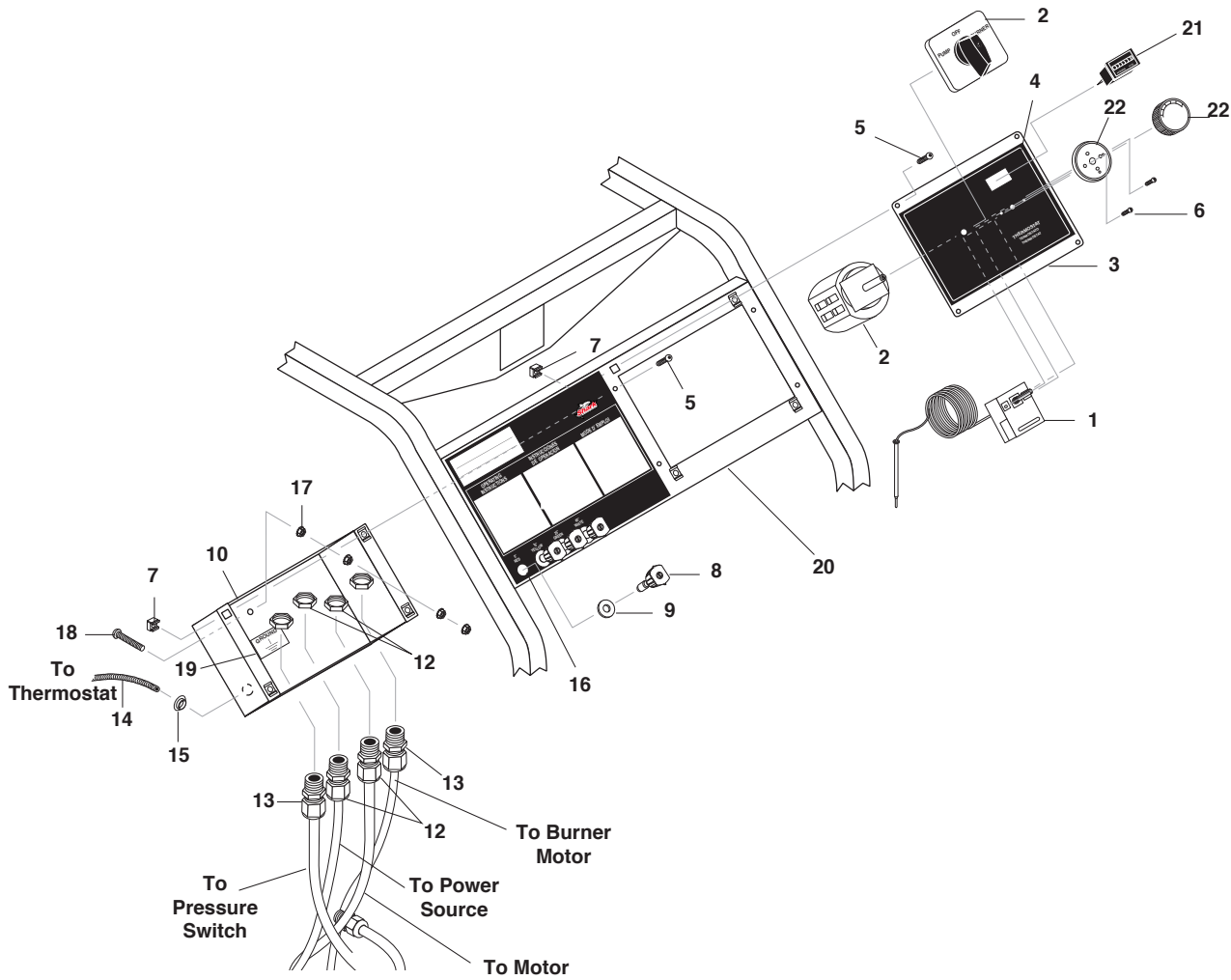

CONTROL PANEL EXPLODED VIEW PARTS LIST

ITEM	PART NO.	DESCRIPTION	QTY	ITEM	PART NO.	DESCRIPTION	QTY
1	8.750-094.0	Thermostat, 150C/302F	1	13	9.802-514.0	Strain Relief, Strt, Lq, Tite	2
2	9.802-449.0	Switch, 3 PS, 120V-230V, 1Ph	1	14	9.802-447.0	Conduit, Corr, Tubing, 1/4"	2 ft.
3	9.804-519.0	Cover, Electric Box, Black	1	15	9.802-103.0	Bushing, Snap, 5/8"	1
	8.922-552.0	Cover, Elec Box (133.0, 134.0)	1	16	9.804-526.0	Label, Karcher	1
4	9.804-520.0	Label, Electric Box	1		8.753-780.0	Label Control Panel (133.0, 134.0)	1
5	9.802-7590	Screw, 10/32" x 1/2" BHSOC Blk	8	17	9.802-695.0	Nut, 10/32" Keps	4
6	8.718-779.0	Screw, 4mm x 6mm	4	18	9.802-762.0	Screw, 10/32" x 1-1/4"	1
7	9.802-791.0	Nut, Cage, 10/32" x 16 Ga	8	19	9.800-040.0	Label, Ground	1
8	See Page 17	Nozzle	4	20	9.804-524.0	Panel, Control, Black	1
9	9.802-064.0	Grommet, Rubber, Nozzle Holder	4		8.922-550.0	Panel, Control (133.0, 134.0)	1
10	9.804-521.0	Box, Electric, black	1		9.802-754.0	▲ Screw, 1/4" x 1/2" HH, NC, Whiz Loc	4
	8.922-551.0	Box, Electric (133.0, 134.0)	1		9.802-775.0	▲ Nut, 1/4" Flange	4
11	8.712-190.0	Bezel, Plastic Thermostat	1	21	9.802-283.0	Hour Meter	1
12	8.752-969.0	Strain Relief, Strt, Lq, Tite Small (231007D, 201507D, 352007A)	2	22	8.750-096.0	Knob Thermostat	1

▲ Not Shown

HOSE AND SPRAY GUN EXPLODED VIEW

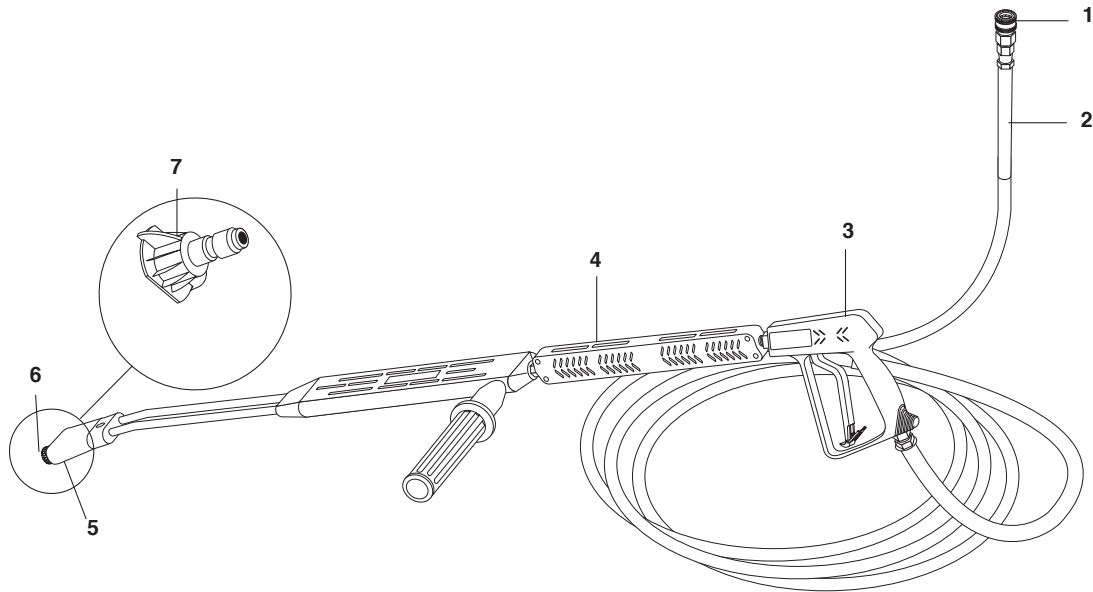

HOSE AND SPRAY GUN PARTS LIST

ITEM	PART NO.	DESCRIPTION	QTY	ITEM	PART NO.	DESCRIPTION	QTY
1	9.802-166.0	Coupler, 3/8" Female	1	7	9.802-288.0	Nozzle, SAQMEG 1503, Yellow (201507D)	1
	9.802-100.0	▲ Quick Coupler O-Ring LG	1		9.802-289.0	Nozzle SAQMEG 2503, Green (201507D)	1
2	8.925-130.0	Hose, 3/8" X 50' 1W 4000PSI SW/SO/CPL	1		9.802-290.0	Nozzle, SAQMEG 4003, White (201507D)	1
3	8.710-384.0	Gun, St-1500, 5000 PSI, 10.4 Gpm	1		8.712-338.0	Nozzle, SAQMEG 1503.5, Yellow (231007D)	1
4	9.802-222.0	Wand, VP Zinc 1/4" w/Coupler, w/Soap Nozzle	1		8.712-339.0	Nozzle, SAQMEG 2503.5, Green (231007D)	1
	9.803-267.0	▲ AL Wand Repair Kit, Stainless Seat	1		8.712-340.0	Nozzle, SAQMEG 4003.5, White (231007D) Red (352007A)	1
5	9.802-286.0	Brass Soap Nozzle Only, 1/8" 1	1		9.802-300.0	Nozzle, SAQMEG 1505 Yellow (352007A)	1
6	9.802-165.0	Coupler, 1/4" Male	1		9.802-301.0	Nozzle, SAQMEG 2505, Green (352007A)	1
	9.802-096.0	Quick Coupler O-Ring Sm	1		9.802-302.0	Nozzle, SAQMEG 4005, White (352007A)	1

▲ Not Shown

VBT UNLOADER EXPLODED VIEW

8.754-696.0

UNLOADER, VBT BANJO 1/2M 3/8M, 3000PSI (SPARE)

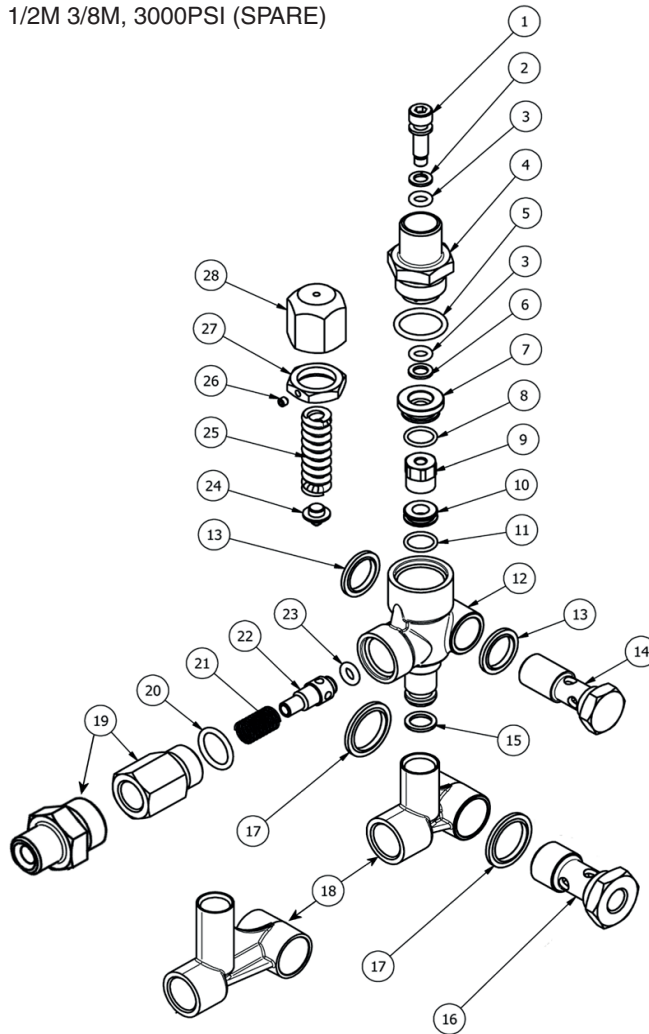

VBT UNLOADER EXPLODED VIEW PARTS LIST

ITEM	PART #	DESCRIPTION	KIT	QTY	ITEM	PART #	DESCRIPTION	KIT	QTY
1*	8.754-929.0	Stem	C	1	17	9.803-914.0	Seal Washer 1/2)		1
2*	9.803-912.0	Backup Ring	A	1	18	8.754-937.0	Bypass Manifold		1
3*	8.754-930.0	O-ring, Ø2.62 x 6.02	A	2	19	9.802-892.0	Outlet Connector 3/8 MPT		1
4	8.730-882.0	Stem Connector		1	20*	9.803-191.0	O-ring, Ø2.62 X 17.13	A,B	1
5*	9.803-193.0	O-ring, Ø2.62 x 20.24	A	1	21*	8.933-017.0	Poppet Spring	B	1
6*	9.803-908.0	Backup Ring	A	1	22*	8.754-939.0	Poppet	B	1
7	9.803-907.0	Guide Bushing		1	23*	8.754-940.0	O-ring, Ø3 x 6	A,B	1
8*	9.803-906.0	O-ring, Ø1.78 x 14	A	1	24*	8.754-961.0	Plate	C	1
9*	8.754-959.0	Ball SubAssembly	C	1	25*	8.933-018.0	Spring 1500-4000 PSI	C	1
10*	8.754-933.0	Seat	C	1	26	8.933-021.0	Set Screw		1
11*	8.754-934.0	O-ring, Ø1.78 x 12.42	A,C	1	27	9.803-925.0	Nut		1
12	8.754-935.0	Valve Body		1	28	9.803-926.0	Knob, Brass, Unloader		1
13	9.802-893.0	Seal Washer 3/8		1	* Included in Kit				
14	9.803-919.0	Banjo Bolt 3/8		1	Kit A	8.754-941.0	O-Ring Repair Kit		
15*	8.754-936.0	O-ring, Ø2.62 x 10.78	A	1	Kit B	8.754-942.0	Outlet Repair Kit		
16	9.803-920.0	Banjo Bolt, 1/2, w/1/4" Port		1	Kit C	8.754-957.0	Stem Repair Kit		

SF SERIES PUMP EXPLODED VIEW

8.923-805.0 SF 2030S

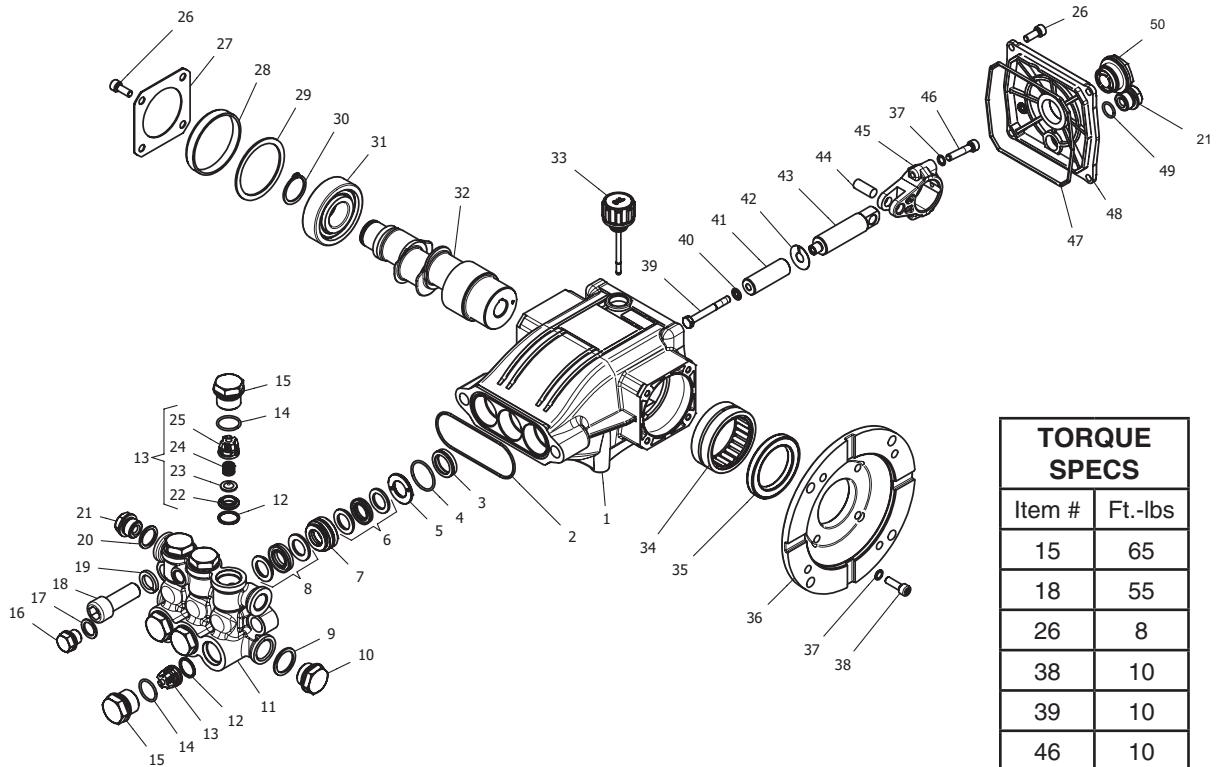

SF SERIES PUMP PARTS LIST

ITEM	PART NO.	DESCRIPTION	QTY	ITEM	PART NO.	DESCRIPTION	QTY
1	8.754-841.0	Crankcase	1	19	8.754-850.0	Washer, Lock	2
2	8.754-846.0	O-ring Ø1.78 X 72.75	1	20	9.803-198.0	Washer, Copper G3/8	1
3*	See Kits Below	Plunger Oil Seal	3	21	8.707-262.0	Plug, Brass G3/8	2
4*	See Kits Below	O-ring Ø1.78 X 26.7	3	22*	See Kits Below	Valve Seat	6
5*	See Kits Below	Washer, Pressure Ring	3	23*	See Kits Below	Valve Plate	6
6*	See Kits Below	U-Seal	3	24*	See Kits Below	Valve Spring	6
7*	See Kits Below	Pressure Ring	3	25*	See Kits Below	Valve Cage	6
8*	See Kits Below	U-Seal	3	26	9.802-939.0	Screw, M6 X 16	8
9	9.803-199.0	Washer, Copper G1/2	1	27	8.717-137.0	Bearing Cover	1
10	9.802-926.0	Plug, Brass G1/2	1	28	9.803-954.0	Bearing Seal	1
11	8.754-852.0	Manifold (16mm Models)	1	29	8.754-843.0	Seal Spacer, Crankshaft	1
	8.754-853.0	Manifold (14mm Models)	1	30	9.802-914.0	Snap Ring, 25 mm	1
12*	8.717-233.0	O-ring Ø1.78 X 15.6	6	31	9.803-955.0	Bearing, Ball	1
13*	See Kits Below	Valve Assembly	6	32	8.754-836.0	Shaft, 5/8" Hollow	1
14*	9.803-948.0	O-ring Ø1.78 X 18.77	6	33	8.754-219.0	Oil Dipstick	1
15	9.803-949.0	Valve Plug	6	34	8.754-840.0	Bearing Needle	1
16	8.754-851.0	Plug, Brass G1/4 (16mm)	1	35	8.754-826.0	Seal, Crankshaft	1
17	8.754-845.0	Washer, Copper G1/4 (16mm models)	1	36	8.754-844.0	Flange, Motor	1
18	8.754-854.0	Bolt, Manifold M14 X 40	2	37	9.803-210.0	Washer	10
				38	8.752-824.0	Screw, 6 mm	4

SF SERIES PUMP PARTS LIST

ITEM	PART NO.	DESCRIPTION	QTY
39*	8.754-855.0	Bolt, Plunger	3
40*	8.754-092.0	Spacer, Copper	3
41	8.754-848.0	Plunger, 16mm	3
42	9.803-962.0	Spacer, Copper	3
43	8.754-827.0	Plunger Rod	3
44	9.803-965.0	Connecting Rod Pin	3
45	9.803-966.0	Connecting Rod	3
46	8.933-020.0	Screw, Connecting Rod	6
47	8.754-847.0	O-ring Ø2.62 X 111.62	1
48	8.754-842.0	Cover, Crankcase	1
49	9.803-906.0	O-ring Ø1.78 X 14	1
50	9.803-202.0	Sight Glass, G3/4	1

*Included in Kit

REPAIR KIT NUMBER	8.754-860.0	8.754-856.0	8.754-861.0	8.754-857.0	8.754-862.0	8.754-858.0	8.754-859.0	9.803-937.0
KIT DESCRIPTION	Plunger Seals 14 mm**	Plunger Seals 16 mm**	Seal Packing 14 mm**	Seal Packing 16 mm**	Plunger 14 mm**	Plunger 16 mm**	Complete Valve	Plunger Oil Seals
ITEM NUMBERS INCLUDED	4, 6, 8	4, 6, 8	4, 5, 6, 7, 8	4, 5, 6, 7, 8	39, 40, 41, 42	39, 40, 41, 42	12, 13, 14	3

SF SERIES PUMP EXPLODED VIEW

8.923-808.0 SF3530F

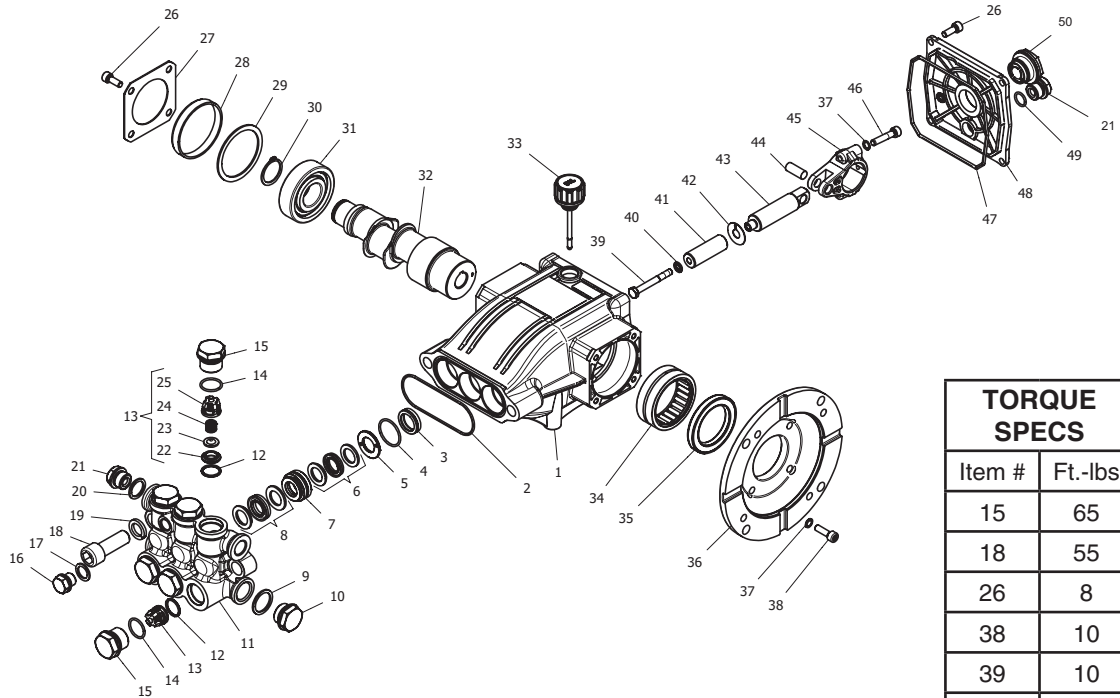

TORQUE SPECS	
Item #	Ft.-lbs
15	65
18	55
26	8
38	10
39	10
46	10

SF SERIES PUMP EXPLODED VIEW PARTS LIST

ITEM	PART NO.	DESCRIPTION	QTY	ITEM	PART NO.	DESCRIPTION	QTY
1	8.754-841.0	Crankcase	1	19	8.754-850.0	Washer, Lock	2
2	8.754-846.0	O-ring Ø1.78 X 72.75	1	20	9.803-198.0	Washer, Copper G3/8	1
3*	See Kits Below	Plunger Oil Seal	3	21	8.707-262.0	Plug, Brass G3/8	2
4*	See Kits Below	O-ring Ø1.78 X 26.7	3	22*	See Kits Below	Valve Seat	6
5*	See Kits Below	Washer, Pressure Ring	3	23*	See Kits Below	Valve Plate	6
6*	See Kits Below	U-Seal	3	24*	See Kits Below	Valve Spring	6
7*	See Kits Below	Pressure Ring	3	25*	See Kits Below	Valve Cage	6
8*	See Kits Below	U-Seal	3	26	9.802-939.0	Screw, M6 X 16	8
9	9.803-199.0	Washer, Copper G1/2	1	27	8.717-137.0	Bearing Cover	1
10	9.802-926.0	Plug, Brass G1/2	1	28	9.803-954.0	Bearing Seal	1
11	8.754-852.0	Manifold (16mm Models)	1	29	8.754-843.0	Seal Spacer, Crankshaft	1
	8.754-853.0	Manifold (14mm Models)	1	30	9.802-914.0	Snap Ring, 25 mm	1
12*	8.717-233.0	O-ring Ø1.78 X 15.6	6	31	9.803-955.0	Bearing, Ball	1
13*	See Kits Below	Valve Assembly	6	32	8.754-839.0	Shaft, 5/8" Hollow	1
14*	9.803-948.0	O-ring Ø1.78 X 18.77	6	33	8.754-219.0	Oil Dipstick	1
15	9.803-949.0	Valve Plug	6	34	8.754-840.0	Bearing Needle	1
16	8.754-851.0	Plug, Brass G1/4 (16mm)	1	35	8.754-826.0	Seal, Crankshaft	1
17	8.754-845.0	Washer, Copper G1/4 (16mm Models)	1	36	8.754-844.0	Flange, Motor	1
18	8.754-854.0	Bolt, Manifold M14 X 40	2	37	9.803-210.0	Washer	10
				38	8.752-824.0	Screw, 6 mm	4

SF SERIES PUMP EXPLODED VIEW PARTS LIST

ITEM	PART NO.	DESCRIPTION	QTY
39*	8.754-855.0	Bolt, Plunger	3
40*	8.754-092.0	Spacer, Copper	3
41	8.754-849.0	Plunger, 14mm	3
42	9.803-962.0	Spacer, Copper	3
43	8.754-827.0	Plunger Rod	3
44	9.803-965.0	Connecting Rod Pin	3
45	9.803-966.0	Connecting Rod	3
46	8.933-020.0	Screw, Connecting Rod	6
47	8.754-847.0	O-ring Ø2.62 X 111.62	1
48	8.754-842.0	Cover, Crankcase	1
49	9.803-906.0	O-ring Ø1.78 X 14	1
50	9.803-202.0	Sight Glass, G3/4	1

REPAIR KIT NUMBER	8.754-860.0	8.754-861.0	8.754-862.0	8.754-859.0	9.803-937.0
KIT DESCRIPTION	Plunger Seals 14 mm	Seal Packing 14 mm	Plunger 14 mm	Complete Valve	Plunger Oil Seals
ITEM NUMBERS INCLUDED	4, 6, 8	4, 5, 6, 7, 8	39, 40, 41, 42	12, 13, 14	3
NO. OF CYLINDERS KIT WILL SERVICE	3	1	1	6	3

BURNER ASSEMBLY EXPLODED VIEW

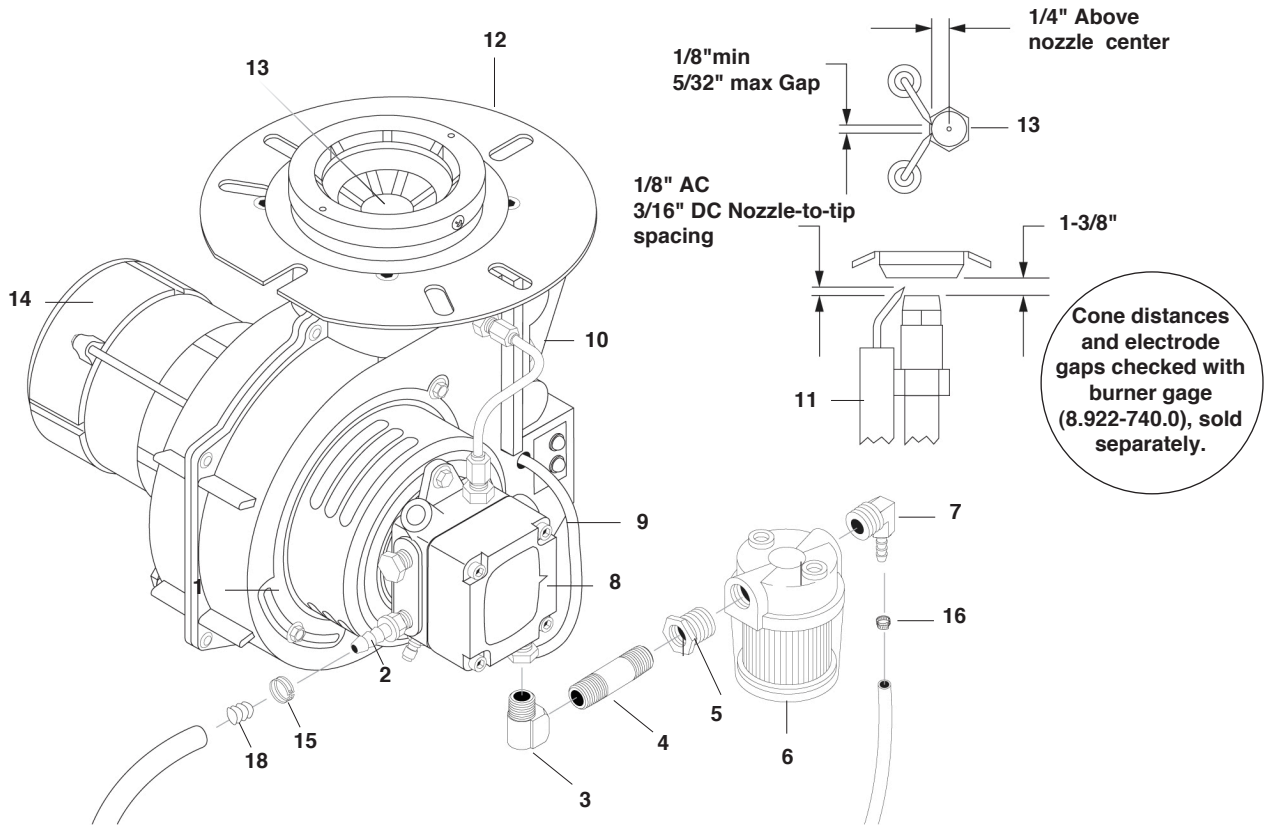

BURNER ASSEMBLY EXPLODED VIEW PARTS LIST

ITEM	PART NO.	DESCRIPTION	QTY	ITEM	PART NO.	DESCRIPTION	QTY
1	8.756-181.0	Burner, MSR 3.75 120V 1T 120V S	1	15	6.390-126.0	Clamp Hose, Uni .46-.54	1
	8.756-709.0	Burner, MSR, 230V 1T 230V S (For models STP-352007A)	1	16	8.750-933.0	Band Hose Clamp, Hose Id 1/8" - 5/16"	1
2	8.706-941.0	Hose Barb, 1/4" Barb x 1/4" Mpt, Brass	1	17	8.754-911.0	Check Valve, 1 way, 1/4"	1
3	8.706-827.0	Elbow, 1/4" Street	1	16	8.717-711.0	▲ Screen, Fuel Filter	1
4	9.803-043.0	Nipple, Pipe 1/4" x 2" Zinc Sch 80 Mpt	1	17	9.802-649.0	▲ Blower Wheel 4.25 x 2.5 Beckett	1
5	8.706-297.0	Bushing, 3/8" Steel Yellow Chrome	1		8.750-520.0	▲ Blower Wheel Crossfire	1
6	8.709-153.0	Filter, Fuel Hotsy, 3/8" Fem	1	18	9.802-648.0	▲ Coupling Assy 5/16" Beckett	1
7	8.706-965.0	Hose Barb, 1/4" Barb x 3/8" ML Pipe, 9	1		8.750-543.0	▲ Coupling Crossfire	1
8	8.700-759.0	Fuel Pump Suntec 120V	1	19	9.802-646.0	▲ Valve Stem Kit Cleancut Pump	1
9	9.802-640.0	Fuel Solenoid	1	20	9.802-666.0	▲ Screen, Fuel Pump	1
10	8.919-114.0	Ignitor, 120V Crossfire	1	21	9.802-514.0	▲ Strain Relief, Lt, Str, 1/2 Npt, .23-.45 D	1
11	8.750-778.0	Electrode Crossfire	1	22	9.802-525.0	▲ Locknut, 1/2"	1
12	9.802-655.0	Air Cone, F-6	1			▲ Not Shown	
13	8.756-861.0	Fuel nozzle, 1.10 X 80 BZ	1				
	8.754-953.0	Fuel Nozzle, 1.75 X 90AZ (For models STP-352007A)	1				
14	8.750-517.0	Motor, 120V Crossfire	1				

WAYNE BURNER EXPLODED VIEW

Replacement Parts

For best performance specify genuine WAYNE replacement parts

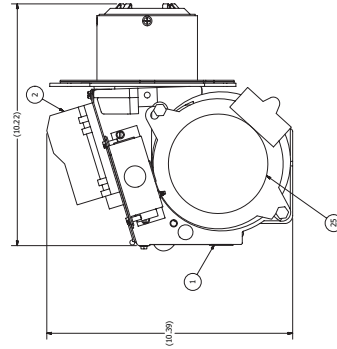
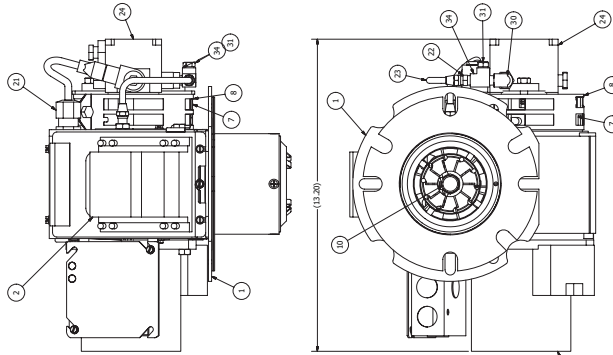
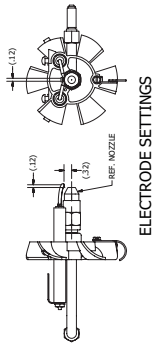

ASSEMBLED VIEWS

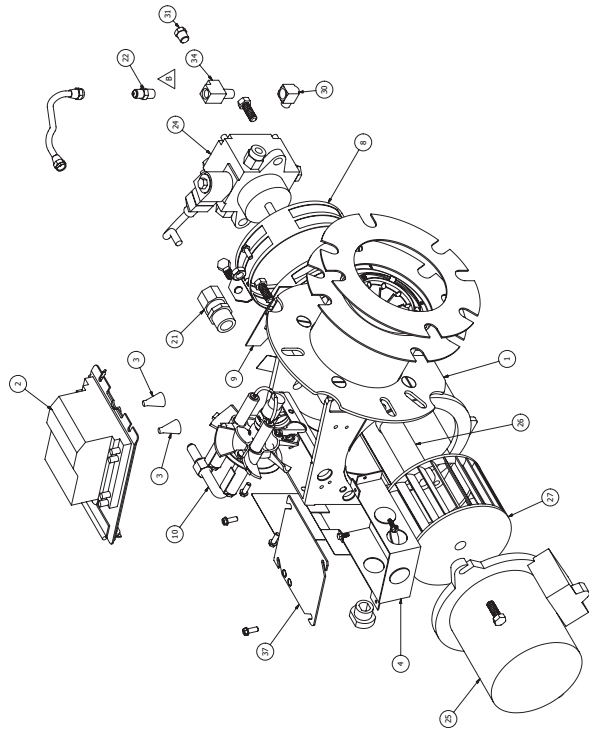

EXPLODED VIEW

WAYNE BURNER PART LIST

Replacement Parts

For best performance specify genuine WAYNE replacement parts

ITEM	PART NO.	DESCRIPTION	QTY
1	101397-001	Tube/Hous-101392-001/ 5A/3.5"/3"l	1
2	101295-002	Ignitor- D W/M Plate 120V	1
3	100990-001	Spring, Contact	1
4	8.756-740.0	Junction Box, MSR, Black Body	1
7	8.700-707.0	Air Band Inner "M"	1
8	20602-002	Band, Air Outer 8-Hole Mod M	1
9	13392	Plate, Slot Cover	1
10	8.756-298.0	Gun Assembly, Burner-RG/*CST/*1 1/4"BB1	1
19	11141	Decal, UL-Under 3 GPH Non C57	1
21	31954-001	Strain Relief-Low Profile	1
22	14222	Connector, Male-3/16" x 1/8" IPT	1
23	8.700-704.0	Oil Line Assembly 6"	1
24	8.756-290.0	Pump - Combo/W Solenoid 120V	1
25	8.756-292.0	Motor 1/7 HP 120/60	1
26	8.700-822.0	Coupling "M"	1
27	8.700-726.0	Fan - 3.12" x 4.25"D 1/2" Bore	1
30	550053	Fitting, Elbow 90* Street 1/8	1
31	15766	Plug, Pipe HXHD 1/8" NPT	1
34	101274-001	Tee, Street-1/8 X 1/8 Brass	1
35	12407	Stopper, #4 Cork	1
36	8.700-692.0	Flange Gasket (2 Each)	2
37	8.756-739.0	Junction Box, MSR, Black Cover	1

Replacement Parts for STP-352007A and STP-352007A

For best performance specify genuine KNA replacement parts

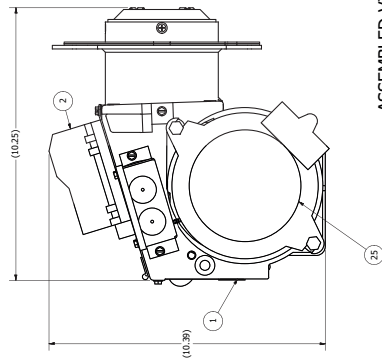
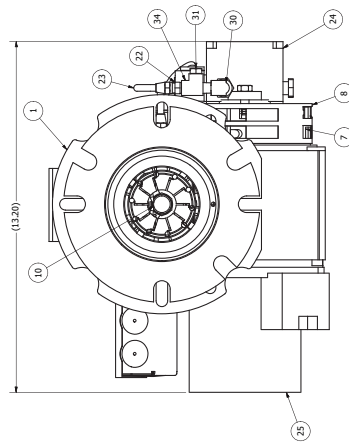
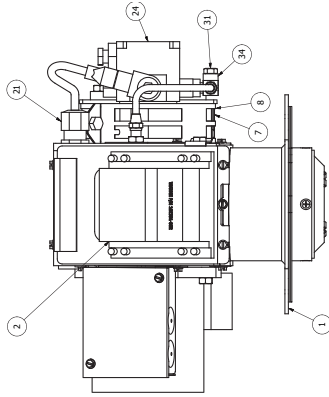
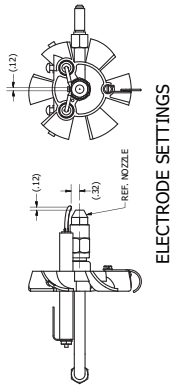

ASSEMBLED VIEWS

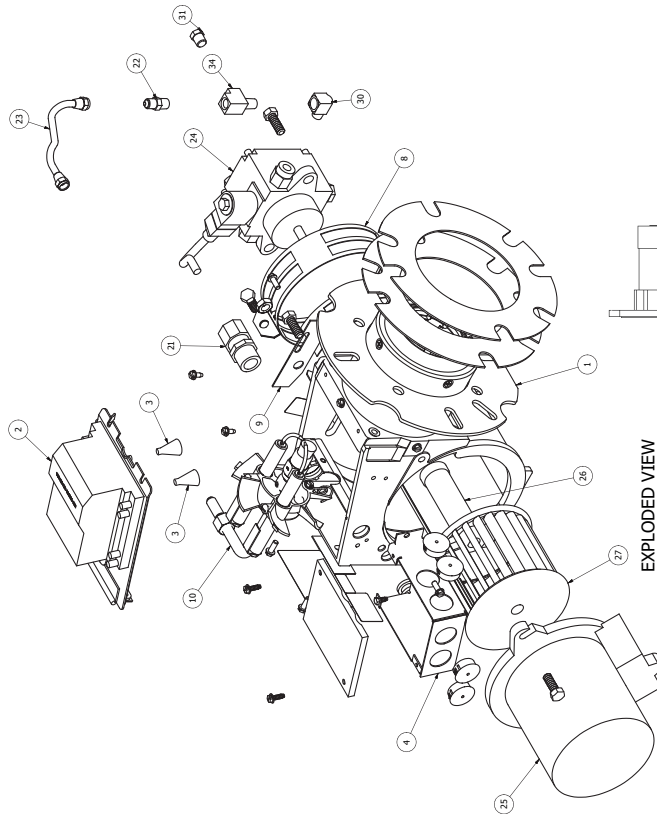

EXPLODED VIEW

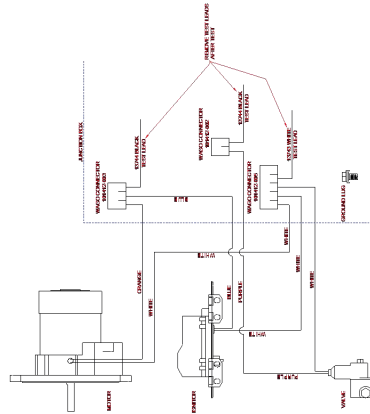

WIRING DIAGRAM

Replacement Parts for STP-352007A and STP-352007A

For best performance specify genuine KNA replacement parts

ITEM	PART NO.	DESCRIPTION	QTY
1	101396-001	Tube/Hous-21922-001/6A/3.75"/.88"l	1
2	101391-002	Ignitor-D W/M Plate 230V	1
3	100990-001	Spring,Contact	2
4	21319-003	J-Box,3X4 (No Knockouts)	1
7	20601-002	Band, Air Inner-Mod M	1
8	20602-002	Band, Air Outer 8-Hole Mod-M	1
9	13392	Plate, Slot Cover	1
10	30537-024	Gun-RG/*CST/*1 1/4"BB	1
21	31954-001	Strain Relief-Low Profile	1
22	14222	Connector, Male-3/16" X 1/8" IPT	1
23	14451	Oil Line ASM.-6"	1
24	101128-010	Pump-S A2VA3006-N753 220V Combo	1
25	24001-001	Motor,1/7 220/230-50/60 PSC	1
26	13424	Coupling-EG1/M "A" Pumps	1
27	21427	FAN-3.44"W X 4.25"D M 1/2" BOR	1
30	550053	Fitting,Elbow 90° Street 1/8	1
31	15766	Plug, PIPE HXHD 1/8" NPT	1
34	101274-001	TEE,Street-1/8 X 1/8 Brass	1
36	12484	Gasket, Flange-STD Large	2

TROUBLESHOOTING

PROBLEM	POSSIBLE CAUSE	SOLUTION
LOW OPERATING PRESSURE	Faulty pressure gauge	Install new gauge.
	Insufficient water supply	Use larger garden hose; clean filter washer at water inlet.
	Old, worn or incorrect spray nozzle	Match nozzle number to machine and/or replace with new nozzle.
	Plumbing or hose leak	Check plumbing system for leaks. Re-tape leaks with teflon tape.
	Faulty or mis-adjusted unloader valve (where applicable)	Adjust unloader for proper pressure. Install repair kit when needed.
	Worn packing in pump	Install new packing kit.
	Fold or dirty inlet or discharge valves in pump	Clean inlet or discharge valves.
	Worn inlet or discharge valves	Replace with valve kit.
DETERGENT NOT DRAWING	Air leak	Tighten all clamps. Check detergent lines for holes.
	Valve in the injector head may be blocked, dirty, or damaged	Clean or replace valve in injector.
	Filler screen on detergent suction hose plugged	Clean or replace.
	Dried up detergent plugging metering valve	Disassemble and clean thoroughly.
	High viscosity of detergent	Dilute detergent to specifications.
	Hole in detergent line(s).	Repair hole.
	Low detergent level	Add detergent if needed.
	Discharge water temperature above 180° F	Lower discharge water temperature.
PUMP RUNNING NORMALLY BUT PRESSURE LOW ON INSTALLATION	Pump sucking air	Check water supply and possibility of air
	Valves sticking	Check and clean or replace if necessary.
	Unloader valve seat faulty	Check and replace if necessary
	Nozzle incorrectly sized	Check and replace if necessary (see serial plate for proper size).
	Worn piston packing	Check and replace if necessary.
FLUCTUATING PRESSURE	Valves worn	Check and replace if necessary.
	Blockage in valve	Check and replace if necessary.
	Pump sucking air	Check water supply and air see page at joints in suction line.
	Worn piston packing	Check and replace if necessary.
PUMP NOISY	Air in suction line	Check water supply and connections on suction line.
	Broken or weak inlet or discharge valve springs	Check and replace if necessary.
	Excessive matter in valves	Check and clean if necessary.
	Worn bearings	Check and replace if necessary.
LOW WATER TEMPERATURE	Improper fuel or water in fuel	Drain fuel tank and replace with proper fuel.
	Low fuel pressure	Increase fuel pressure.
	Weak fuel pump	Check fuel pump temperature. Replace pump if needed.
	Fuel filter partially clogged	Replace as needed.
	Soot build up on coils	Clean coils with soot remover.
	Lime build up on coils	Clean inside of coils using coil cleaner.
	Improper burner nozzle	Call technical service for proper size.
WATER TEMPERATURE TOO HOT	Incoming water to machine warm or hot	Lower incoming water temperature.
	Fuel pump pressure too high	Lower fuel pressure.
	Fuel pump defective	Replace fuel pump.
	Detergent line sucking air	Tighten all clamps. Check detergent line for holes.
	Defective high limit switch (thermostat)	Replace.
	Insufficient water supplied	Check GPM to machine.
	Restricted water flow	Check nozzle for obstruction, proper size.

MAINTENANCE SCHEDULE

PREVENTATIVE MAINTENANCE

This pressure washer was produced with the best available materials and quality craftsmanship. However, you as the owner have certain responsibilities for the correct care of the equipment. Attention to regular preventative maintenance procedures will assist in preserving the performance of your equipment. Contact your local pressure washer dealer for maintenance. Regular preventative maintenance will add many hours to the life of your pressure washer. Perform maintenance more often under severe conditions.

MAINTENANCE SCHEDULE		
Replace Fuel Lines		Annually
Pump Oil (Non foaming) SAE 10W-40	Inspect	Daily inspect the oil level
	Change	After first 50 hours, then every 500 hours or annually
Clean Burner Filter		Monthly (more often if fuel quality is poor)
Remove Burner Soot		Annually
Burner Adjustment/Cleaning		Annually
Descale Coil		Annually (more often if required)
Replace High Pressure Nozzle		Every 6 months
Replace Quick Connects		Annually
Clean Water Screen/Filter		Weekly
Clean Float/Supply Tank		Every 6 months
Replace HP Hose		Annually if there is any sign of wear
Grease Motor		Every 10,000 hours
Replace Burner Nozzle		Annually

OIL CHANGE RECORD

Date Oil Changed Month/Day/Year	Estimated Operating Hours Since Last Oil Change

Date Oil Changed Month/Day/Year	Estimated Operating Hours Since Last Oil Change

**LIMITED NEW PRODUCT
WARRANTY—COMMERCIAL
PRESSURE WASHERS**

KÄRCHER

Phone: 888-805-9852
Fax: 800-248-8409
www.karchercommercial.com

WHAT THIS WARRANTY COVERS

All Kärcher commercial pressure washers are warranted by Kärcher to the original purchaser to be free from defects in materials and workmanship under normal use, for the periods specified below. This Limited Warranty, subject to the exclusions shown below, is calculated from the date of the original purchase, and applies to the original components only. Any parts replaced under this warranty will assume the remainder of the pressure washer's warranty period.

SEVEN YEAR PARTS AND ONE YEAR LABOR WARRANTY

Components manufactured by Kärcher, such as frames, handles, top and bottom wraps, float tanks, fuel tanks, and belt guards. Xpert Series cold water pressure washer have a three-year frame warranty. Internal components on the oil-end of Kärcher Classic series, electric powered axial pumps have a 5 year warranty. Period of warranty on gas-engine axial pumps shall be one year; Kärcher crankshaft pumps have a 7 year warranty on non-wear parts. Heating coils have a five year warranty from date of original machine purchase; stainless steel coils have a 10 year warranty.

ONE YEAR PARTS AND ONE YEAR LABOR WARRANTY

All other components, excluding normal wear items as described below, will be warranted for one year on parts and labor. Parts and labor warranty on these parts will be for one year regardless of the duration of the original component manufacturer's part warranty.

WARRANTY PROVIDED BY OTHER MANUFACTURERS

Motors, generators, and engines, which are warranted by their respective manufacturers, are serviced through these manufacturers' local authorized service centers. Kärcher is not authorized and has no responsibility to provide warranty service for such components. Motors manufactured outside of the United States will be warranted by Kärcher.

WHAT THIS WARRANTY DOES NOT COVER

This warranty does not cover the following items:

1. Normal wear items, such as nozzles, spray guns, discharge hoses, wands, quick couplers, seals, filters, gaskets, O-rings, packings, pistons, pump valve assemblies, strainers, belts, brushes, rupture disks, fuses, pump protectors.
2. Any components or other devices incorporated into a Kärcher product that are not manufactured by Kärcher, including, but not limited to gasoline engines, pumps, etc.
3. Defects caused by improper or negligent operation or installation, accident, abuse, misuse, neglect, unauthorized modifications, repair or maintenance of the product by persons other than authorized representatives of Kärcher, including, but not limited to, the failure of the Customer to comply with recommended product maintenance schedules.
4. Kärcher products that have been returned by the original Customer and are ultimately re-sold by an Authorized Servicing Dealer or other sales or service outlet to another purchaser.
5. Kärcher products that are sold by any distributor or retailer that is not an official authorized dealer or retailer of Kärcher products.
6. Defects caused by acts of nature and disaster including, but not limited to, floods, fires, wind, freezing, earthquakes, tornadoes, hurricanes and lightning strikes.
7. Defects caused by water sediments, rust corrosion, thermal expansion, scale deposits or a contaminated water supply (such as water in the unit with chloride content higher than that of 80 mg/liter or use of chemicals not approved or recommended by Kärcher).
8. Defects caused by improper voltage, voltage spikes or power transients in the electrical supply.
9. Devices or accessories not distributed or approved by Kärcher.
10. Any cost of labor arising from the removal and reinstallation of the alleged defective part by Customer.
11. Transportation of the product to an Authorized Servicing Dealer, field labor, replacement rental and any freight charges.

Any components, accessories or other devices provided with the product but not manufactured by Kärcher (such as engines, pumps, etc.) are subject to warranties and service through their respective manufacturers authorized service centers and according to the applicable terms and conditions of such manufacturers warranties. Such components or other devices not manufactured by Kärcher should be referred by the Customer to an authorized service center or their respective manufacturers for repair or replacement.

THE FOREGOING WARRANTY IS IN LIEU OF ALL OTHER WARRANTIES OF ANY KIND, WHETHER ARISING BY LAW, CUSTOM OR CONDUCT. KÄRCHER MAKES NO ADDITIONAL WARRANTIES, EITHER EXPRESSED OR IMPLIED, INCLUDING, WITHOUT LIMITATION, ANY EXPRESSED OR IMPLIED WARRANTIES OF MERCHANTABILITY OR FITNESS OF EQUIPMENT FOR A PARTICULAR PURPOSE AND ANY SUCH WARRANTIES ARE EXPRESSLY DISCLAIMED. KÄRCHER FURTHER DISCLAIMS ANY WARRANTY THAT THE PRODUCT PURCHASED BY CUSTOMER WILL MEET ANY PARTICULAR REQUIREMENT OF CUSTOMER EVEN IF KÄRCHER HAS BEEN ADVISED OF SUCH REQUIREMENT.

THE RIGHTS AND REMEDIES PROVIDED UNDER THIS WARRANTY ARE EXCLUSIVE AND IN LIEU OF ANY OTHER RIGHTS OR REMEDIES OF CUSTOMER. KÄRCHER SHALL NOT UNDER ANY CIRCUMSTANCES BE LIABLE TO ANY PERSON OR ENTITY INCLUDING, BUT NOT LIMITED TO, THE CUSTOMER OR ANY END USER OF THE PRODUCT FOR ANY SPECIAL, INDIRECT, INCIDENTAL OR CONSEQUENTIAL DAMAGES OR ECONOMIC LOSS, LOSS OF PROFITS OR LOSS OF USE OF THE PRODUCT, ARISING IN CONNECTION WITH THE SALE, DELIVERY, INSTALLATION, TRAINING OR USE OF PRODUCT.

KÄRCHER'S LIABILITY, WHETHER IN CONTRACT OR IN TORT, ARISING OUT OF ANY WARRANTIES OR REPRESENTATIONS, INSTRUCTIONS OR DEFECTS FROM ANY CAUSE, SHALL BE LIMITED EXCLUSIVELY TO THE COST OF REPAIR OR REPLACEMENT PARTS UNDER AFORESAID CONDITIONS.

The purpose of the foregoing limitations on liability and Customer remedies is to protect Kärcher from unknown or undeterminable risks. Some states do not allow the exclusion or limitation of incidental or consequential damages, so the above limitation or exclusion may not apply to the Customer.

Kärcher sales and service representatives are not authorized to waive or alter the terms of this warranty, or to increase the obligations of Kärcher under the warranty.

Kärcher reserves the right to make design changes in any of its products without prior notification to the Customer.

PRESSURE WASHER WARRANTY



www.karcher.com/us

Form # 9.801-191.0 • Revised 04/19 • Printed in U.S.A. or Mexico