



**MODELS: 965SS, 1065SS,
1065SSE, 1075SSE,
1075BE Compact**

OPERATING INSTRUCTIONS AND PARTS MANUAL

Thank you for purchasing a Hotsy Pressure Washer. This manual covers the operation and maintenance of your pressure washer. All information in this manual is based on the latest product information available at the time of printing. Hotsy, Inc. reserves the right to make changes at any time without incurring any obligation.

Read instructions carefully before attempting to assemble, install, operate or service this pressure washer. Failure to comply with instructions could result in personal injury and/or property damage!



<p>SERIAL NUMBER:</p>	
<p>DATE PURCHASED:</p>	
<p>FOR SALES AND SERVICE, PLEASE CONTACT:</p> <p>Scan or Click to View The Hotsy Safety Video</p> 	

965SS SPECIFICATIONS

1.110-015.0

- Pump Volume At Pump Head: 3.0 GPM/180 GPH
- Pump Pressure At Pump Head: 3000 PSI
- Burner Type: Fuel Oil Fired, 248,000 BTU/Hr.
- Burner Fuel Pressure: 205 PSI Max.
- Machine Displacement: 270cc
- Exhaust Stack Size: 8"
- Machine Dimensions: Length=47",
Width=31", Height=47"

1065SS SPECIFICATIONS

1.110-010.0

- Pump Volume At Pump Head: 3.5 GPM/210 GPH
- Pump Pressure At Pump Head: 3000 PSI
- Burner Type: Fuel Oil Fired, 309,900 BTU/Hr.
- Burner Fuel Pressure: 205 PSI Max.
- Machine Displacement: 337cc
- Exhaust Stack Size: 8"
- Machine Dimensions: Length=47",
Width=31", Height=49"

1065SSE SPECIFICATIONS

1.110-011.0

- Pump Volume At Pump Head: 3.5 GPM/210 GPH
- Pump Pressure At Pump Head: 3000 PSI
- Burner Type: Fuel Oil Fired, 309,900 BTU/Hr.
- Burner Fuel Pressure: 205 PSI Max.
- Machine Displacement: 389cc Electric Start
- Exhaust Stack Size: 8"
- Machine Dimensions: Length=47",
Width=31", Height=49"

1075SSE SPECIFICATIONS

1.110-012.0

- Pump Volume At Pump Head: 3.8 GPM/228 GPH
- Pump Pressure At Pump Head: 3500 PSI
- Burner Type: Fuel Oil Fired, 309,900 BTU/Hr.
- Burner Fuel Pressure: 205 PSI Max.
- Machine Displacement: 389cc Electric Start
- Exhaust Stack Size: 8"
- Machine Dimensions: Length=47",
Width=31", Height=49"

1075BE COMPACT CAL SPECIFICATIONS

1.110-088.0

- Pump Volume At Pump Head: 3.8 GPM/228 GPH
- Pump Pressure At Pump Head: 3500 PSI
- Burner Type: Fuel Oil Fired, 309,900 BTU/Hr.
- Burner Fuel Pressure: 205 PSI Max.
- Machine Displacement: 408cc Electric Start
- Exhaust Stack Size: 8"
- Machine Dimensions: Length=47",
Width=31", Height=49"

965SS CAL SPECIFICATIONS

1.110-090.0

- Pump Volume At Pump Head: 3.0 GPM/180 GPH
- Pump Pressure At Pump Head: 3000 PSI
- Burner Type: Fuel Oil Fired, 248,000 BTU/Hr.
- Burner Fuel Pressure: 205 PSI Max.
- Machine Displacement: 408cc Electric Start
- Exhaust Stack Size: 8"
- Machine Dimensions: Length=47",
Width=31", Height=47"

1065SSE CAL SPECIFICATIONS

1.110-089.0

- Pump Volume At Pump Head: 3.5 GPM/210 GPH
- Pump Pressure At Pump Head: 3000 PSI
- Burner Type: Fuel Oil Fired, 309,900 BTU/Hr.
- Burner Fuel Pressure: 205 PSI Max.
- Machine Displacement: 408cc Electric Start
- Exhaust Stack Size: 8"
- Machine Dimensions: Length=47",
Width=31", Height=49"

1075SSE CAL SPECIFICATIONS

1.110-080.0

- Pump Volume At Pump Head: 3.8 GPM/228 GPH
- Pump Pressure At Pump Head: 3500 PSI
- Burner Type: Fuel Oil Fired, 309,900 BTU/Hr.
- Burner Fuel Pressure: 205 PSI Max.
- Machine Displacement: 408cc Electric Start
- Exhaust Stack Size: 8"
- Machine Dimensions: Length=47",
Width=31", Height=49"

1075BE COMPACT SPECIFICATIONS

1.110-099.0

- Pump Volume At Pump Head: 3.8 GPM/228 GPH
- Pump Pressure At Pump Head: 3500 PSI
- Burner Type: Fuel Oil Fired, 309,900 BTU/Hr.
- Burner Fuel Pressure: 205 PSI Max.
- Machine Displacement: 389cc Electric Start
- Exhaust Stack Size: 8"
- Machine Dimensions: Length=47",
Width=31", Height=49"

CONTENTS

Introduction & Important Safety Information.....	4
Component Identification.....	7
Assembly Instructions.....	8
Installation	9
Operation Instructions	11
General Cleaning Techniques & Storage	13
Maintenance	14
Troubleshooting.....	15
Exploded View - Left Side	18
Exploded View - Right Side.....	19
1075BE Compact Power Platform Assembly	21
Control Panel Assembly exploded view & parts list.....	22
Fuel Tank Assembly and parts list.....	23
Hose, Spray Gun & Wand Assembly and parts list	23
Burner Assembly exploded view.....	24
Beckett Burner Exploded View	25
Wayne Burner Exploded View	26
Pump Assembly - 965SS.....	28
Pump Assembly - 1065SS, 1065SSE, 1075SSE	29
Pump Assembly - 1075BE Compact	30
Coil Outlet Exploded View - 965SS 1065SS 1065SSE 1075SE.....	31
Coil Inlet Assembly	32
HS.3 Pump Exploded View	33
HM.3 Series Pump exploded view.....	35
HPP3035G1 Series Pump Exploded View	37
VBA Unloader exploded view	39
VBT Unloader Exploded View	40
Wiring Diagram - 965SS, 1065SS.....	41
Wiring Diagram - 1065SSe, 1075SSE.....	42
Wiring Diagram - 1075BE Compact	44
Wiring Diagram - Burner All Models	45

Model Number _____

Serial Number _____

Date of Purchase _____

The model and serial numbers will be found on a decal attached to the pressure washer. You should record both serial number and date of purchase and keep in a safe place for future reference.

INTRODUCTION & IMPORTANT SAFETY INFORMATION

Thank you for purchasing this Pressure Washer. We reserve the right to make changes at any time without incurring any obligation.

Owner/User Responsibility:

The owner and/or user must have an understanding of the manufacturer's operating instructions and warnings before using this pressure washer. Warning information should be emphasized and understood. If the operator is not fluent in English, the manufacturer's instructions and warnings shall be read to and discussed with the operator in the operator's native language by the purchaser/owner, making sure that the operator comprehends its contents.

Owner and/or user must study and maintain for future reference the manufacturers' instructions. The operator must know how to stop the machine quickly and understand the operation of all controls. Never permit anyone to operate the engine without proper instructions.

SAVE THESE INSTRUCTIONS

This manual should be considered a permanent part of the machine and should remain with it if machine is resold.

When ordering parts, please specify model and serial number. Use only identical replacement parts.

This machine is to be used only by trained operators.

IMPORTANT SAFETY INFORMATION

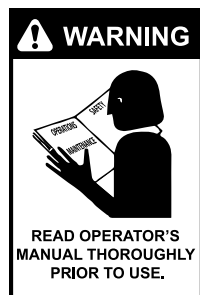

WARNING: To reduce the risk of injury, read operating instructions carefully before using.

1. Read the owner's manual thoroughly. Failure to follow instructions could cause malfunction of the machine and result in death, serious bodily injury and/or property damage.
2. Know how to stop the machine and bleed pressure quickly. Be thoroughly familiar with the controls.
3. Stay alert — watch what you are doing.



WARNING: Keep wand, hose, and water spray away from electric wiring or fatal electric shock may result.

4. All installations must comply with local codes. Contact your electrician, plumber, utility company or the selling distributor for specific details.



WARNING: This machine exceeds 85 db appropriate ear protection must be worn.



WARNING: High pressure spray can cause paint chips or other particles to become airborne and fly at high speeds. To avoid personal injury, eye, hand and foot safety devices must be worn.

5. Eye, hand, and foot protection must be worn when using this equipment.
6. Keep operating area clear of all persons.



WARNING: Flammable liquids can create fumes which can ignite, causing property damage or severe injury.

WARNING: Risk of explosion — Operate only where open flame or torch is permitted.



WARNING: Risk of fire — Do not add fuel when the product is operating or still hot.

WARNING: Do not use gasoline crankcase draining or oil containing gasoline, solvents or alcohol. Doing so will result in fire and/or explosion.

WARNING: Risk of fire — Do not Spray flammable liquids.

IMPORTANT SAFETY INFORMATION

WARNING: This product contains chemicals known to the state of California to cause cancer and birth defects or other reproductive harm. Operation of this equipment may create sparks that can start fires around dry vegetation. A spark arrestor may be required. The operator should contact: Local fire agencies for laws or regulations relating to fire prevention requirements.

7. Allow engine to cool for 1-2 minutes before refueling. If any fuel is spilled, make sure the area is dry before testing the spark plug or starting the engine. (Fire and/or explosion may occur if this is not done.)

Gasoline engines on mobile or portable equipment shall be refueled:

- a. outdoors;
- b. with the engine on the equipment stopped;
- c. with no source of ignition within 10 feet of the dispensing point; and
- d. with an allowance made for expansion of the fuel should the equipment be exposed to a higher ambient temperature.

In an overfilling situation, additional precautions are necessary to ensure that the situation is handled in a safe manner.

WARNING: Risk of injury. Disconnect battery ground terminal before servicing.

8. When in use, do not place machine near flammable objects as the engine is hot.
9. Oil burning appliances shall be installed only in locations where combustible dusts and flammable gases or vapors are not present. Do not store or use gasoline near this machine.
10. Use No. 1 or No. 2 heating oil (ASTM D306) only. **NEVER** use gasoline in your fuel oil tank. Gasoline is more combustible than fuel oil and could result in a serious explosion. **NEVER** use crankcase or waste oil in your burner. Fuel unit malfunction could result from contamination.
11. Do not confuse gasoline and fuel oil tanks. Keep proper fuel in proper tank.



WARNING: Risk of injury. Hot surfaces can cause burns. Use only designated gripping areas of spray gun and wand. Do not place hands or feet on non-insulated areas of the pressure washer.

12. Transport/Repair with fuel tank EMPTY or with fuel shut-off valve OFF.



WARNING: Hot discharge fluid. Do not touch or direct discharge stream at persons or animals.

WARNING: This machine produces hot water and must have insulated components attached to protect the operator.

13. To reduce the risk of injury, close supervision is necessary when a machine is used near children. Do not allow children to operate the pressure washer. **This machine must be attended during operation.**



WARNING: Grip cleaning wand securely with both hands before starting. Failure to do this could result in injury from a whipping wand.

14. Never make adjustments on machine while in operation.

15. Be certain all quick coupler fittings are secured before using pressure washer.



WARNING: High pressure developed by these machines will cause personal injury or equipment damage. Keep clear of nozzle. Use caution when operating. Do not direct discharge stream at people or animals, or severe injury or death will result.



WARNING: Protect machine from freezing.

16. To keep machine in best operating conditions, it is important you protect machine from freezing. Failure to protect machine from freezing could cause malfunction of the machine and result in death, serious bodily injury, and/or property damage.

Follow storage instructions specified in this manual.

17. Inlet water must be clean fresh water and no hotter than 145°F.

IMPORTANT SAFETY INFORMATION



WARNING: Risk of asphyxiation.
Use this product only in a well ventilated area.

18. Avoid installing machines in small areas or near exhaust fans. Adequate oxygen is needed for combustion or dangerous carbon monoxide will result.

19. Manufacturer will not be liable for any changes made to our standard machines or any components not purchased from us.

20. The best insurance against an accident is precaution and knowledge of the machine.



WARNING: Be extremely careful when using a ladder, scaffolding or any other relatively unstable location. The cleaning area should have adequate slopes and drainage to reduce the possibility of a fall due to slippery surfaces.

21. Do not allow acids, caustic or abrasive fluids to pass through the pump.
22. Never run pump dry or leave spray gun closed longer than 1-2 minutes.
23. Machines with shut-off spray gun should not be operated with the spray gun in the off position for extensive periods of time as this may cause damage to the pump.
24. Protect discharge hose from vehicle traffic and sharp objects. Inspect condition of high pressure hose before using or bodily injury may result.
25. Before disconnecting discharge hose from water outlet, turn burner off and open spray gun to allow water to cool below 100° before stopping the machine. Then open the spray gun to relieve pressure. Failure to properly cool down or maintain the heating coil may result in a steam explosion.

26. Do not overreach or stand on unstable support. Keep good footing and balance at all times.
27. Do not operate this machine when fatigued or under the influence of alcohol, prescription medications, or drugs.
28. In oil burning models, use only kerosene, No. 1 home heating fuel, or diesel. If diesel is used, add a soot remover to every tankful.



Follow the maintenance instructions specified in the manual.

COMPONENT IDENTIFICATION

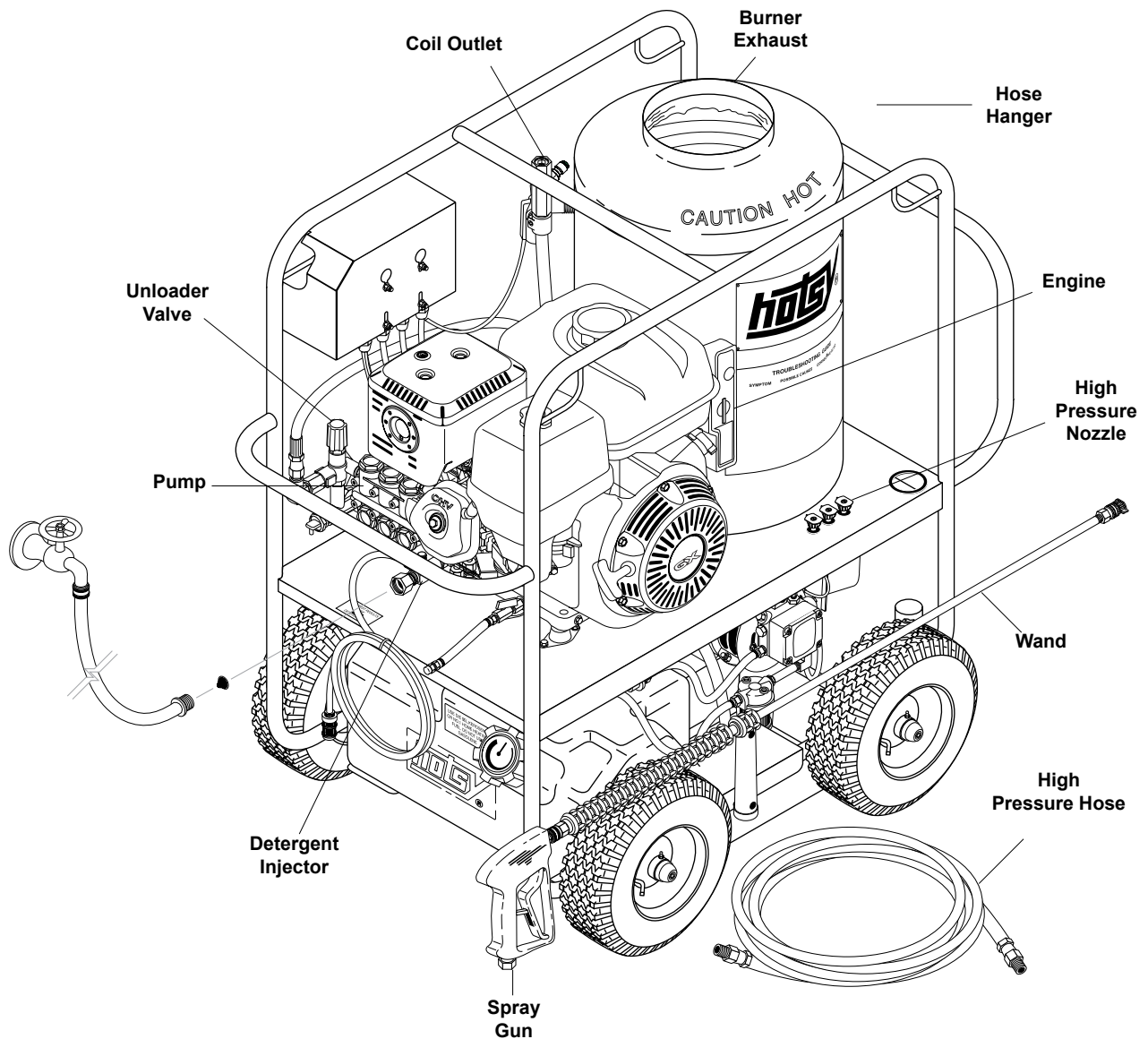

Pump — Delivers a specific gpm to the high pressure nozzle which develops pressure.

Spray Gun — Controls the application of water and detergent onto cleaning surface with trigger device. Includes safety latch.

Detergent Injector — Allows you to siphon and mix detergents.

Wand — Must be connected to the spray gun.

High Pressure Hose — Connect one end to water pump high pressure discharge nipple and the other end to spray gun.

Unloader Valve — Safety device which, when the spray gun closes, redirects flow of water.

Note: If trigger on spray gun is released for more than 2 minutes, water may leak from the pump protector. Warm water will discharge from pump protector onto floor. This system prevents internal pump damage.

ASSEMBLY INSTRUCTIONS

Unpacking

Unpack carefully. Wear safety glasses or goggles while unpacking, assembling, or operating pressure washer. If there are missing components or hidden damage, immediately contact carrier concerning discrepancies.

1. Cut strapping band from pressure washer and pallet.
2. Remove pressure washer from pallet.

Parts Included

- Pressure Washer
- Pressure Hose
- Wand
- Operating Instructions and Parts Manual
- Gasoline Engine Manual
- Parts Bag Containing:
 - Pressure Nozzles (3 Ea.)
 - Trigger Gun
 - Battery Terminals (2 Ea.)

Tools Required

- 8" Adjustable Wrench
- Teflon Tape
- Flat Blade Screwdriver

Pressure Hose, Trigger Gun and Wand

1. When assembling, use teflon tape on all threaded plumbing connections to prevent leakage.
2. Install the pressure hose on the pressure washer as shown in **Figure 1**.

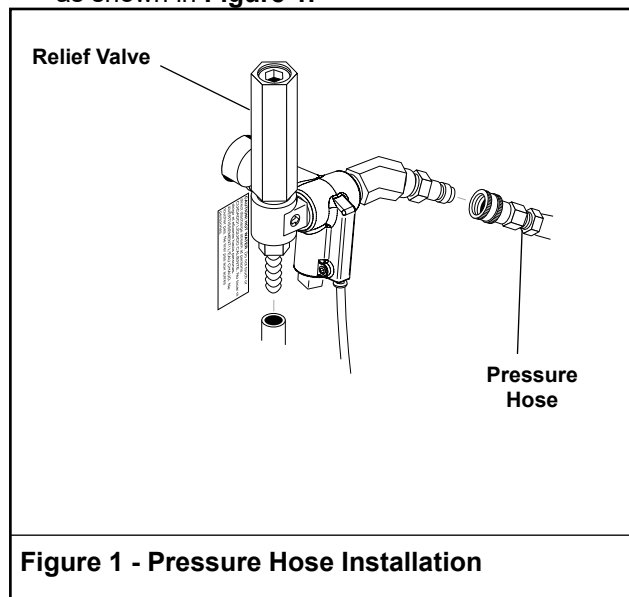

Figure 1 - Pressure Hose Installation

3. Assemble wand components as shown in **Figure 2**.

NOTE: The pressure nozzle is not to be installed at this time.

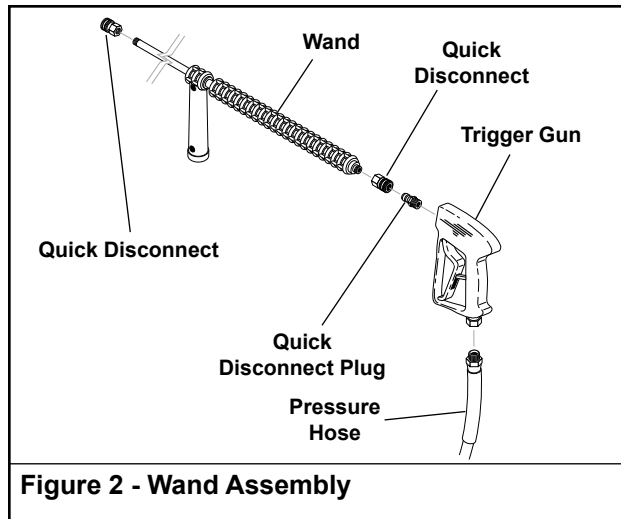

Figure 2 - Wand Assembly

4. Make sure all plumbing connections are tight.

Battery

WARNING: Wear eye, hand and skin protection when handling or connecting battery.

WARNING: Batteries generate explosive gases during normal battery operation.

WARNING: DO NOT expose the battery to flame or sparks as these gases may ignite.

WARNING: Battery fluid is highly acidic. If battery fluid contacts skin or clothing, wash immediately with soap and water. If battery fluid enters eye, immediately flood eye with running cold water for at least 15 minutes and get immediate medical attention.

1. **Electric Start Machines Only:** Place battery in battery box (battery not included). Use a standard 12 volt automotive battery. Select a battery similar to the one in **Figure 3** for proper fit and installation.
2. Install the battery terminals as shown in **Figure 4**.

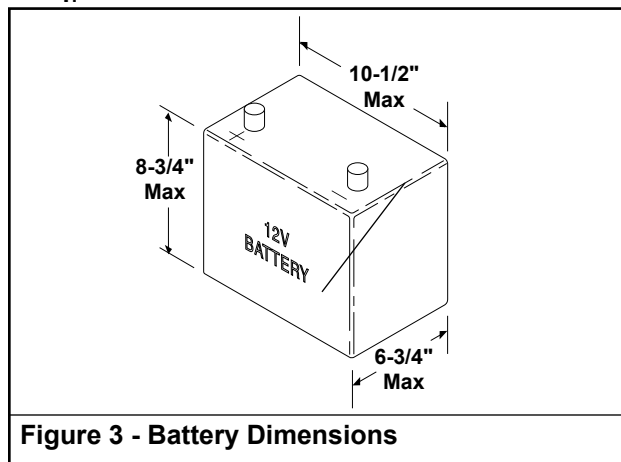
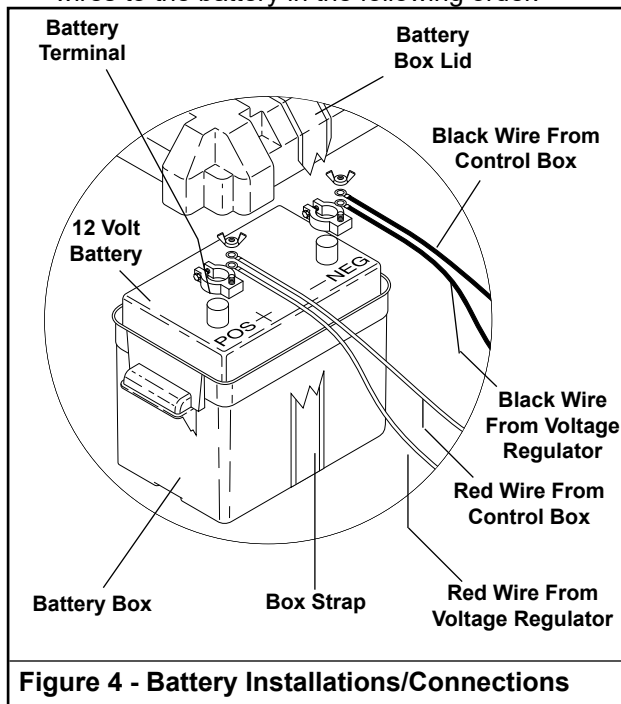

Figure 3 - Battery Dimensions

ASSEMBLY & INSTALLATION INSTRUCTIONS

- To reduce the possibility of sparking attach the wires to the battery in the following order.



Refer to **Figure 4**. First attach the red wire from the voltage regulator and the red wire from the control box to the positive "+" terminal of battery. Next, attach the black wire from the voltage regulator and the black wire from the control box to the negative "-" terminal of the battery. To disconnect the battery remove the wires in the opposite order as installed. Install battery box cover and fasten in place.

INSTALLATION

Responsibility

The owner and/or user must have an understanding of the manufacturer's operating instructions and warnings before using this Hotsy pressure washer. Warning information should be emphasized and understood. If the operator is not fluent in English, the manufacturer's instructions and warnings shall be read to and discussed with the operator in the operator's native language by the purchaser/owner, making sure that the operator comprehends its contents.

Owner and/or user must study and maintain for future reference the manufacturers' instructions.

This manual should be considered a permanent part of the machine and should remain with it if machine is resold.

When ordering parts, please specify model and serial number.

Getting Started

IMPORTANT: Proper initial installation of equipment will assure more satisfactory performance, longer service life, and lower maintenance cost.

IMPORTANT: The use of a backflow preventer on the water supply hose is recommended and may be required by local code.

The pressure washer should be run on a level surface and in a protected area where it is not readily influenced by outside forces such as strong winds, freezing temperatures, rain, etc. The pressure washer should be located to assure easy access for filling of fluids, adjustments and maintenance. Normal precautions should be taken by the operator to prevent moisture from reaching the pressure washer. It is recommended that a partition be made between the wash area and the pressure washer to prevent direct spray from the wand from coming in contact with the pressure washer. Moisture reaching the equipment will reduce the pressure washer's service life. All installations must comply with the local codes covering such installations.

Venting

CAUTION: All venting must be in accordance with applicable federal and state laws, and local ordinances. Consult local heating contractors.

If the pressure washer is to be used in an enclosed area, a flue must be installed to vent burner and engine exhaust to the outside atmosphere. Be sure the flue is the same size as the burner exhaust vent on the pressure washer. See **Component Identification** for location. Poor draft will cause the pressure washer to soot and not operate properly. When selecting the location for installation, beware of poorly ventilated locations or areas where exhaust fans may cause an insufficient supply of oxygen. Proper combustion can only be obtained when there is a sufficient supply of oxygen available for the amount of fuel being burned. If it is necessary to install the machine in a poorly ventilated area, outside fresh air may have to be piped to the burner and a fan installed to bring sufficient air into the machine. Locate the pressure washer so that the flue will be as straight as possible and protrude through the roof at a proper height and location to provide adequate draft. This oil fired pressure washer must have a draft regulator installed in the flue (available from most heating contractors). A draft regulator will permit proper upward flow of exhaust flue gases.

In addition, the pressure washer should never be operated in an enclosed area where high ambient

INSTALLATION INSTRUCTIONS

temperatures exist. High ambient temperatures (above 100° F) can cause engine oil failure and will greatly reduce the engine's performance.

Gasoline Engine

The gasoline engine is preset for operation at altitudes below 1000 feet above sea level. If operated at higher altitudes, it may be necessary to install a high altitude main jet in the carburetor. Contact a local authorized engine sales and service center for details.

Pre-Operation Check

- Pump Oil (SAE 10W-40 non foaming)
- Cold Water Supply (6 gpm • 5/8" • 20 psi)
- Hose, wand, nozzle (nozzle size per serial plate)
- Water filter (intact, nonrestrictive)
- Engine fuel (unleaded 86 or higher)
- Engine oil (SAE 10W30)
- Burner fuel (No. 1 or No. 2 home heating fuel or diesel)

If the desired position cannot be obtained using only the air shutter, lock the air shutter in as close a position as can be obtained, then repeat the above procedure on the air band setting.

CAUTION: If white smoke appears from burner exhaust vent during start-up or operation, discontinue use and readjust air bands.

NOTE: If a flue is installed, have a professional serviceman adjust your burner for a #1 or #2 smoke spot on the Bacharach scale.

Oil Burner

Burner Air Adjustment:

The oil burner on this machine is preset for operation at altitudes below 500 feet. If operated at higher altitudes, it may be necessary to adjust the air band for a #1 or #2 smoke spot on the Bacharach scale. To adjust, start machine and turn burner ON. Loosen two locking screws found on the air band and close air band until black smoke appears from burner exhaust vent. Note air band position. Next, slowly open the air band until white smoke just starts to appear. Turn air band halfway back to the previously noted position. Tighten locking screws.

- For higher altitudes, the air band opening may need to be increased; for lower altitude, the air band may need to be decreased.
- For higher humidity, the air band opening may need to be increased; for lower relative humidity, the air band may need to be decreased.
- For higher ambient temperatures the air band opening may need to be increased; for lower ambient temperatures, the air band opening may need to be decreased.

Adjust to your operating location's environment as-needed for best smoke spot and performance compliant with local, state, and federal regulations.

Fuel Pressure Adjustment:

To adjust fuel pressure, First install a pressure gage into the port just after the pump fuel exit. Turn the adjusting screw (located at the regulator port) clockwise to increase, and counterclockwise to decrease. Do not exceed 205 psi or lower the pressure below 130 PSI, when checked at the post-pump pressure port.

The fuel pressure may need to be adjusted due to altitude. For every 500 ft altitude above sea level, the boiling point of water goes down 1 °F. At high altitude environments, this boiling point change may require the heat input to be lowered so the water input does not turn to steam earlier than at the factory settings and activate the pressure sensors and pressure relief equipment when the unit is operated and much higher altitudes from factory settings or local dealer site settings. Check with your dealer before making local site fuel pressure adjustments.

Also, as ambient temperature changes seasonally, the fuel temperature in the feed tank and air temperature inlet can impact fuel flow. In more extreme temperatures, this local-site adjustment may also require different fuel nozzles for fuel inlet temperatures that are at seasonal extremes (higher or lower) in locations where the temperature changes are beyond moderate temperatures of between 40°F and 90°F. Colder temperatures will make for a thicker flow and less fine a fuel spray while hotter temperatures will make for a thinner flow a more fine spray with the same nozzle. Consider alternate nozzle configurations from the baseline factory-supplied nozzle for operating in such temperature extremes if performance is not meeting needs with air band and fuel pressure settings alone.

NOTE: When changing fuel pump, a by-pass plug must be installed in return line port or fuel pump will not prime.

OPERATION INSTRUCTIONS

Before Starting

1. Read all manuals provided with this pressure washer. Become familiar with location and function of all operating and safety controls.

WARNING: Check hoses, fittings, wand, trigger gun and fuel connections daily for signs of wear, cracks and looseness, and replace as required.

2. Connect water supply hose to the garden hose connector located on pump. The water faucet and supply hose must be capable of providing a minimum of 3.5 gallons per minute (GPM).
3. Fill oil burner fuel tank. Use kerosene, #1 grade home heating oil, #1 or #2 diesel fuel. **DO NOT USE GASOLINE, CRANKCASE OIL DRAININGS, OR WASTE OIL.**

WARNING: DO NOT fill engine fuel tank while engine is running or hot. Let engine cool before refueling or spontaneous fire may result. Fuel spillage or vapors could ignite if engine is hot.

4. Fill the engine fuel tank. Do not overfill, fill to the bottom of filler neck only. Use lead free gasoline minimum 86 octane. **DO NOT** use gasoline containing more than 15% MTBE, 5% methanol or 10% ethanol. Refer to the provided gasoline engine manual for additional details.
5. Check pump and engine oil levels.
6. If detergents are to be used, only use detergents intended for pressure washers. Follow instructions on the detergent container.

IMPORTANT: Before installing pressure nozzle on initial start-up, turn on the water supply and allow water to run from the end of the wand until clear to prevent the pressure nozzle from clogging.

IMPORTANT: If the pressure washer has not been used for an extended period of time, remove the pressure nozzle from the end of the wand and turn on water supply. Allow water to run from the end of the wand until clear.

7. Install the proper pressure nozzle for your cleaning needs on the end of wand, refer to **Figure 6**.

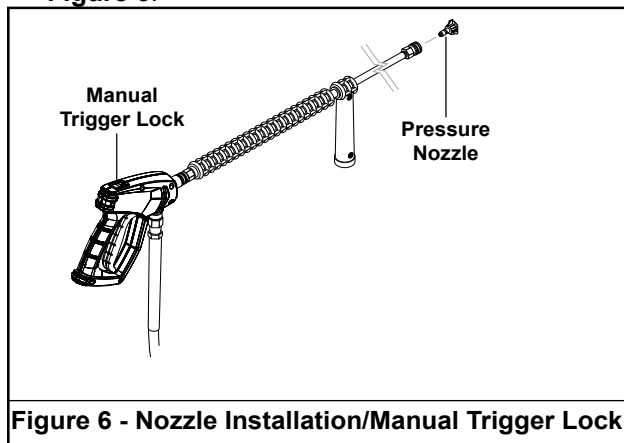

Figure 6 - Nozzle Installation/Manual Trigger Lock

IMPORTANT: The trigger gun provided with this pressure washer is equipped with a manual trigger lock to prevent accidental operation of the trigger gun. (Refer to Figure 6.) The manual trigger lock should be used whenever the trigger gun is not in use.

To Start

IMPORTANT: The water must be turned on before starting. Running the pump dry will cause damage and void warranty.

IMPORTANT: DO NOT allow the machine to run with trigger of the trigger gun released for more than 2 minutes at any one time or damage to pump may occur.

1. Turn ON water supply.
2. Hold wand firmly, release trigger of trigger gun.
3. Place engine ON/OFF switch in the ON position.
4. Open fuel shutoff valve (if so equipped). Move choke lever to FULL CHOKE position, (choke may not be needed on warm engine). Move throttle lever to HALF THROTTLE position.
5. Pull the rope starter slowly until resistance is felt, then pull briskly. Do not allow the rope starter to snap back against the engine. Return it gently to prevent damage to the starter.
6. When the engine starts, move choke lever until engine runs smoothly. When engine warms, move choke lever to NO CHOKE position. Move throttle lever to FULL THROTTLE position.

INOTE: If engine fails to start, refer to Troubleshooting Guide in this manual.

7. Squeeze trigger of trigger gun and allow air to purge from system.
8. If hot water is desired, adjust the thermostat to the proper temperature and turn burner switch ON. The burner will light immediately with a small puff of smoke. You may need to initially adjust your burner for peak performance. See **Oil Burner** section under **Installation**. When the trigger of the trigger gun is released or when the thermostat temperature setting is reached, the burner will automatically turn off.

To Clean

The detergent injector valve operates by reducing the volume of water, thus a vacuum is achieved and detergent is drawn into the system. **DO NOT** reduce the water inlet flow so the pump cavities due to water starvation. Operating a pump with insufficient water will damage the pump seals.

1. Insert detergent inlet line into container of mixed detergent.

OPERATION INSTRUCTIONS

2. Completely open detergent control knob located on the side of the detergent injector valve. Refer to **Figure 7**.

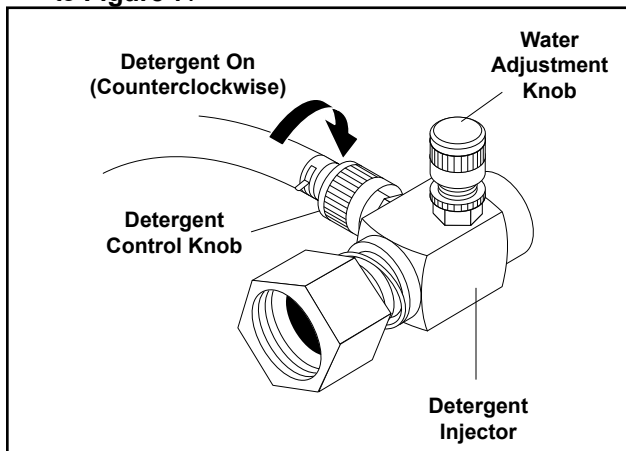

Figure 7 - Detergent Injector Valve

3. Start the detergent suction by rotating the water adjustment knob of the detergent injector valve. Refer to **Figure 7**. Turning the knob counterclockwise will pull detergent into the system. The flow may be observed through the clear detergent line. Secure the knob position with the knurled nut.
4. The side detergent control knob can now be adjusted to meter the desired amount of detergent.
5. Wash from the bottom to the top, using side to side motions. This washes away heavy dirt and allows the detergent to soak as you work toward the top.
6. Do not wash at a 90° angle to the work (straight at it). This will allow water to splash back at you and reduces your cleaning power. Wash at a 30° to 60° angle to the work. This will allow the water to splash away from you and the water will wash the dirt away faster and easier.
7. Use the width of the spray pattern to wash in a wide path. Overlap spray paths for complete

coverage washing from side to side, using slow, steady motions.

8. The nozzle should be 12" to 24" from work, closer for tough areas. Be careful on painted or delicate surfaces, the pressure may damage surface if nozzle is too close.
9. Small parts should be washed in a basket so the pressure does not push them away. Larger, lightweight parts should be clamped down so the pressure does not push them away.
10. Turn the side detergent control knob clockwise (CW) for detergent decrease. Wait for detergent to clear. Always rinse with cold water after using detergent. Rinse from the top to the bottom to prevent detergent from dripping onto a rinsed area. For the best results, contact your Hotsy dealer to help you select the best detergent for your application.

To Stop

1. If detergents were used, draw clear water through the detergent inlet line to purge detergent. Failure to do so may clog detergent injector valve.
2. If burner was used, turn OFF burner switch and allow pump to run cold water through coil for several minutes.
3. Move throttle lever to idle position.
4. Turn engine ON/OFF switch to the OFF position.
5. Close fuel shutoff valve (if so equipped).
6. Turn water supply OFF.
7. Squeeze trigger of trigger gun to relieve system pressure.

GENERAL CLEANING TECHNIQUES & STORAGE

Pre-rinse cleaning surface with fresh water. Place detergent suction tube directly into cleaning solution and apply to surface at low pressure (for best results, limit your work area to sections approximately 6 feet square and always apply detergent from bottom to top). Allow detergent to remain on surface 1-3 minutes. Do not allow detergent to dry on surface. If surface appears to be drying, simply wet down surface with fresh water. If needed, use brush to remove stubborn dirt. Rinse at high pressure from top to bottom in an even sweeping motion keeping the spray nozzle approximately 1 foot from cleaning surface. Use overlapping strokes as you clean and rinse any surface. For best surface cleaning action spray at a slight angle.

Recommendations:

- Before cleaning any surface, an inconspicuous area should be cleaned to test spray pattern and distance for maximum cleaning results.
- If painted surfaces are peeling or chipping, use extreme caution as pressure washer may remove the loose paint from the surface.
- Keep the spray nozzle a safe distance from the surface you plan to clean. High pressure wash a small area, then check the surface for damage. If no damage is found, continue to pressure washing.



CAUTION - Never use:

- Bleach, chlorine products and other corrosive chemicals
- Liquids containing solvents (i.e., paint thinner, gasoline, oils)
- Tri-sodium phosphate products
- Ammonia products
- Acid-based products

These chemicals will harm the machine and will damage the surface being cleaned.

RINSING

It will take a few seconds for the detergent to clear. Apply safety latch to spray gun. Select and install desired high pressure nozzle. **NOTE:** You can also stop detergent from flowing by removing detergent siphon tube from bottle.

STORAGE

DANGER: DO NOT store flammable liquids (gasoline, diesel fuel, solvents, etc.) near pressure washer, or in non-ventilated areas.

Protect from freezing by storing in a heated area, or by flushing the system with antifreeze (use an automotive engine antifreeze or windshield washer solvent to antifreeze). To flush the system with antifreeze, the following steps are to be followed:

1. Connect water supply hose to the garden hose connector located on the pump. Turn on water supply.

2. Place the detergent inlet line into a container of antifreeze.
3. Hold wand firmly, release trigger of trigger gun.
4. Start engine. Place throttle lever in Full Throttle position.
5. Squeeze trigger of trigger gun and allow water to flow from the end of the wand. Watch for antifreeze to be drawn through the detergent inlet line. Allow the antifreeze to be drawn into the system for 5 to 10 seconds.
6. Release the trigger of the trigger gun and stop engine.
7. Turn off water supply and disconnect water supply hose from the pump.
8. Attach a short length of hose (approximately 3 feet long) to the garden hose connector located on the pump. Install a funnel in the other end of the hose as shown in **Figure 8**.

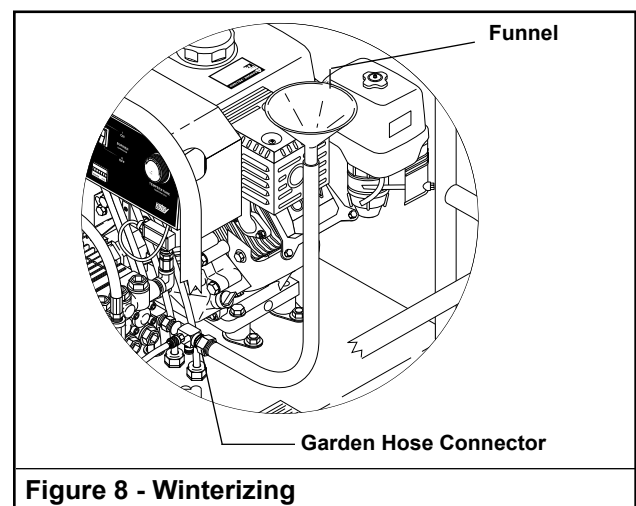

Figure 8 - Winterizing

9. Hold wand firmly, release the trigger of the trigger gun.
10. Start engine. Place throttle lever in the idle position.
11. Squeeze trigger on trigger gun.
12. Slowly pour antifreeze into the funnel. Continue to add antifreeze until antifreeze flows from the end of the wand.
13. Squeeze and release the trigger of the trigger gun several times to antifreeze the unloader system.
14. Release the trigger of the trigger gun. Stop engine.
15. Squeeze the trigger of the trigger gun to relieve system pressure.

For added protection, after anti freezing, disconnect the pressure hose from the machine and remove the coil drain plug (refer to **Component Identification** for location.) After coil has drained, replace pressure hose and coil drain plug. If the pressure washer is not to be used for an extended length of time, it is recommended that the system be flushed with antifreeze for rust protection. Refer to the **Gasoline Engine Manual** for engine storage information.

MAINTENANCE

WARNING: Unauthorized machine modification or use of non-approved replacement parts may cause personal injury and/or property damage and will void the manufacturer warranty.

Pump

Lubrication: To lubricate pump, use SAE 10W-40 (non foaming) oil for pump crankcase. Crankcase must be filled to center of red dot on oil gauge found on the side of the pump, refer to **Figure 9**. During the break-in-period, make sure the oil is changed after the first 40 hours of operation. After that, replace oil every 3 months or 500 hours of operation, whichever comes first.

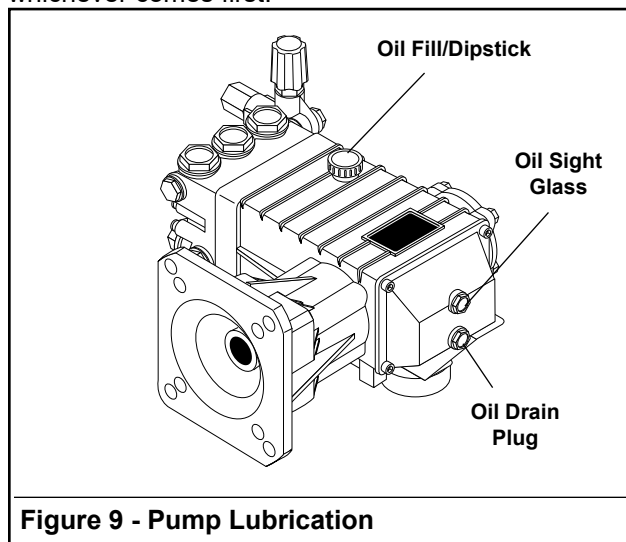

Figure 9 - Pump Lubrication

Proper Pump Care:

- **DO NOT** pump acids.
- **DO NOT** allow pump to run dry.
- Winterize if storing in freezing temperatures, refer to **Storage** for details.
- Use a water softener on the water system if known to be high in mineral content.
- Use only high quality detergents and follow manufacturer's mix recommendations.
- Flush the system with clear water immediately after using detergent solutions.
- Clean filter screen on detergent inlet line periodically.
- Flush the pressure washer system with antifreeze if storing for an extended period of time, refer to **Storage** for details.

Gasoline Engine

Refer to the provided **Gasoline Engine Manual** for recommended maintenance.

Oil Burner

Blower Motor: Inspect the motor brushes for wear every 250 hours of operation and replace when 1/8" to 1/4" brush material remains. **DO NOT** allow the brushes to wear out completely or motor damage

will occur. Refer to **Burner Assembly**. The motor bearings are permanently lubricated and will not require any additional lubrication.

Unloader Valve/ Relief valve

WARNING: The unloader valve and relief valve on this pressure washer has been factory set and sealed and is a field nonadjustable part. Tampering with the factory setting may cause personal injury and/or property damage, and will void the manufacturer warranty. For replacement refer to Pump Assembly.

Burner Fuel Filter

Drain any water which has accumulated in fuel filter and clean or replace filter element as needed. Refer to **Burner Assembly**.

Heating Coil

Coil Descaling: In hard water areas, scale buildup within the heating coil will occur. Scale deposits will decrease the water temperature rise and may eventually clog the heating coil. Contact your local service center when descaling is needed.

Coil Desooting: Poor grades of fuel oil or inadequate combustion air will cause heavy soot buildup on the outside surface of the heating coil. These deposits will insulate the coil. This will restrict the air flow through the coil, further aggravating the soot buildup. Contact your local service center when desooting is needed.

Hour Meter

This hour meter will monitor the total hours of operation of the pressure washer to signal when routine maintenance is required.

Battery

Refer to **battery manufacturer's literature** for recommended maintenance.

Relief Valve

WARNING: The relief valve on this pressure washer has been factory set and sealed and is a field non-adjustable part. Tampering with the factory setting may cause personal injury and/or property damage, and will void the manufacturer warranty. For replacement parts refer to Coil Outlet Assembly.

If pressure from pump or thermal expansion should exceed safe limits, the relief valve will open, allowing high pressure to be discharged through hose to ground. **Caution: Inspect relief valve annually for any obstruction.**

TROUBLESHOOTING

SYMPTOM	POSSIBLE CAUSES	CORRECTIVE ACTION
GAS ENGINE WILL NOT RUN.	Out of gas	Replenish supply. Use only recommended fuels. Refer to Before Starting under Operation.
	Fuel valve closed (if so equipped)	Open valve.
	Loose spark plug wire	Reconnect.
	Choke or throttle set incorrectly	Refer to To Start under Operation.
	Engine ON/OFF switch in OFF position	Place engine ON/OFF switch in ON position.
	Low engine oil level	Replenish supply. Engine will not start or run if oil is low (on engines equipped with low oil protection).
	Refer to provided gasoline engine manual for additional troubleshooting.	
PRESSURE WASHER RUNS BUT WON'T SPRAY.	Trigger of trigger gun released	Squeeze trigger.
	Water supply not turned on	Open water supply valve.
	Clogged pressure nozzle	Clean pressure nozzle opening.
	If water spray doesn't show with in 10-15 seconds	Discontinue running the machine and troubleshoot as damage to the pump will occur if allowed to run.
LOW SPRAY PRESSURE AT PRESSURE NOZZLE.	Inadequate water supply	Fully open faucet. Check for kinked or damaged hose. Use 3/4 inch minimum hose. Check for debris clogging inlet screen.
	Partially clogged or damaged pressure nozzle	Clean or replace.
	Air being drawn through detergent inlet line	Refill detergent container. Ensure that pick-up screen is fully immersed.
	Detergent injector valve not set correctly	Refer to To Clean for settings.
UNEVEN SPRAY PATTERN.	Partially clogged or damaged pressure nozzle	Clean or replace.
PRESSURE WASHER WILL NOT PRODUCE HOT WATER.	Burner switch in OFF position	Place switch in ON position.
	Inadequate fuel supply	Refill fuel tank. Use only recommended fuels. Refer to Before Starting under Operation.
	Inadequate water supply	Fully open faucet. Check for kinked or damaged hose. Use 3/4 inch minimum hose. Check for debris clogging inlet screen.
	Trigger of trigger gun released	Squeeze trigger. Water must be spraying for burner to light.
	Thermostat set too low	Adjust thermostat to desired temperature.
	Blown fuse	Replace. Fuse is located in control box.
	Engine is running too slow	Move throttle lever to full throttle position.

TROUBLESHOOTING

SYMPTOM		POSSIBLE CAUSES	CORRECTIVE ACTION
POOR OR NO DETERGENT FLOW.		Inadequate detergent supply.	Refill detergent container. Ensure that pick-up screen is fully immersed. Open detergent valve.
		Detergent screen or hose clogged.	Clean. Always start with a clean detergent container.
		Detergent injector valve not set correctly.	Refer to To Clean for settings.
		Clogged detergent injector check valve.	Clean check valve at detergent injector inlet
POOR CLEANING.		Improper detergent concentration or mixing.	Mix detergent per manufacturer's instructions. Ensure that powdered detergents are fully dissolved.
		Wrong detergent for the application.	Select appropriate detergent.
		Rinsing with hot water.	A final rinse with cold water will reduce water spotting.
MACHINE SMOKES A) SMOKES WHILE UNIT IS RUNNING B) SMOKES AT COLD-START WHEN BURNER IS OF	AB	Improper fuel or water in fuel	Drain tank and replace contaminated fuel.
	AB	Improper air adjustment	Readjust air bands on burner assembly.
	AB	Low fuel pressure < 140 PSI	Adjust fuel pump pressure to specifications.
	AB	Weak fuel pump	Check fuel pump pressure. Replace pump if needed.
	AB	Fuel filter partially clogged	Replace as needed.
	AB	Soot build up on coils	Clean coils with soot remover.
	AB	Lime build up in coils	Clean inside of coils using Landa's coil cleaner.
	AB	Improper burner nozzle	See combustion assembly breakdown.
	AB	Electrode is misaligned	Realign electrodes to specs.
	B	Fuel pressure is too high for clean burn (Fuel PSI above 140 but less than 200)	Reduce fuel PSI / increase air and band set for cleaner burn without max water heat loss.
WATER TEMPERATURE TOO HOT.		Incoming water to machine warm or hot	Lower incoming water temperature.
		Fuel pump pressure too high	Lower fuel pressure.
		Fuel pump defective	Replace fuel pump.
		Detergent line sucking air	Tighten all clamps. Check detergent line for holes.
		Defective high limit switch	Replace.
		Incorrect fuel nozzle size	See exploded view parts list for proper size.
		Insufficient water supplied	Check G.P.M. to machine.
		Restricted water flow	Check nozzle for obstruction, proper size.

TROUBLESHOOTING

IMPORTANT

If the pressure washer demonstrates other symptoms or the corrective actions listed do not correct the problem, contact the local authorized Hotsy Service Center. The Hotsy Service Center can be identified by visiting www.hotsy.com.

When ordering from your dealer, please provide the following:

Model Number: 965SS, 1060SS, 1065SS, 1065SSE, 1075SSE

Machine Serial Number: _____

Component Part Number: _____

Description:

EXPLODED VIEW - LEFT SIDE

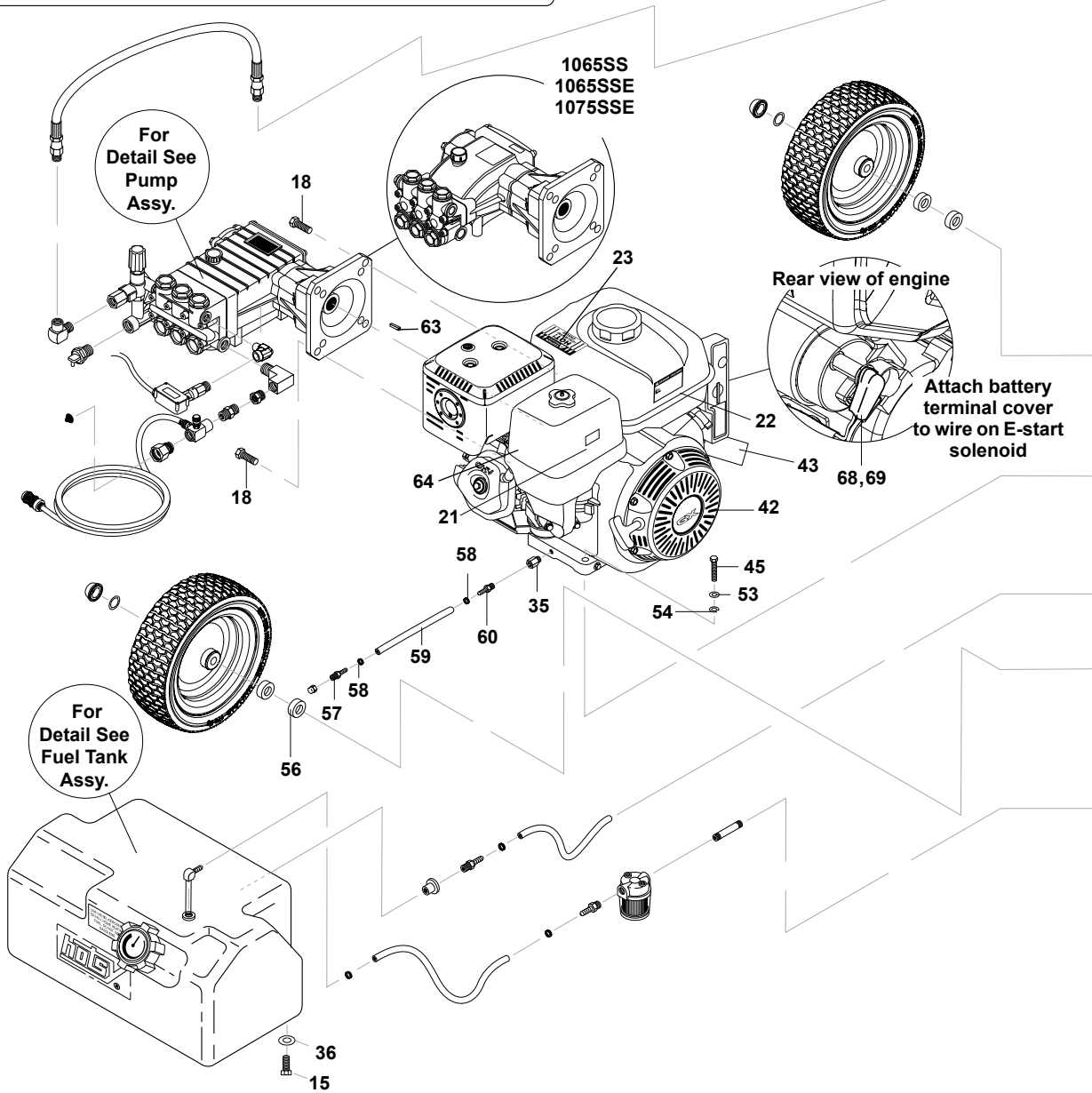
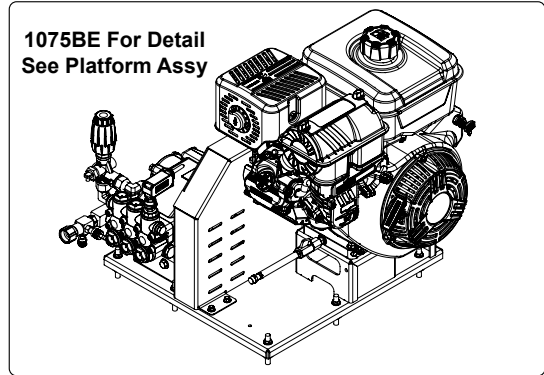
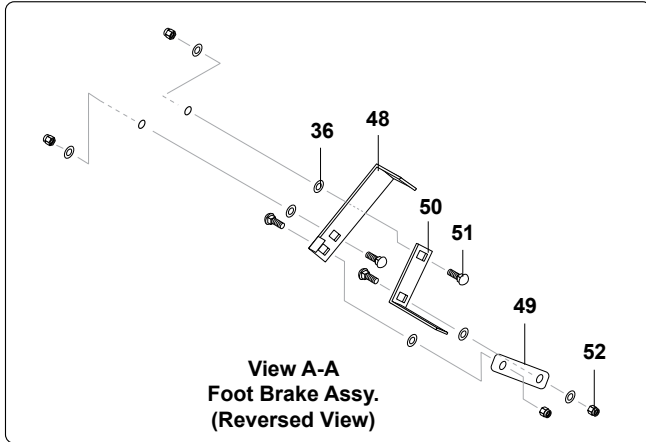

EXPLODED VIEW - RIGHT SIDE

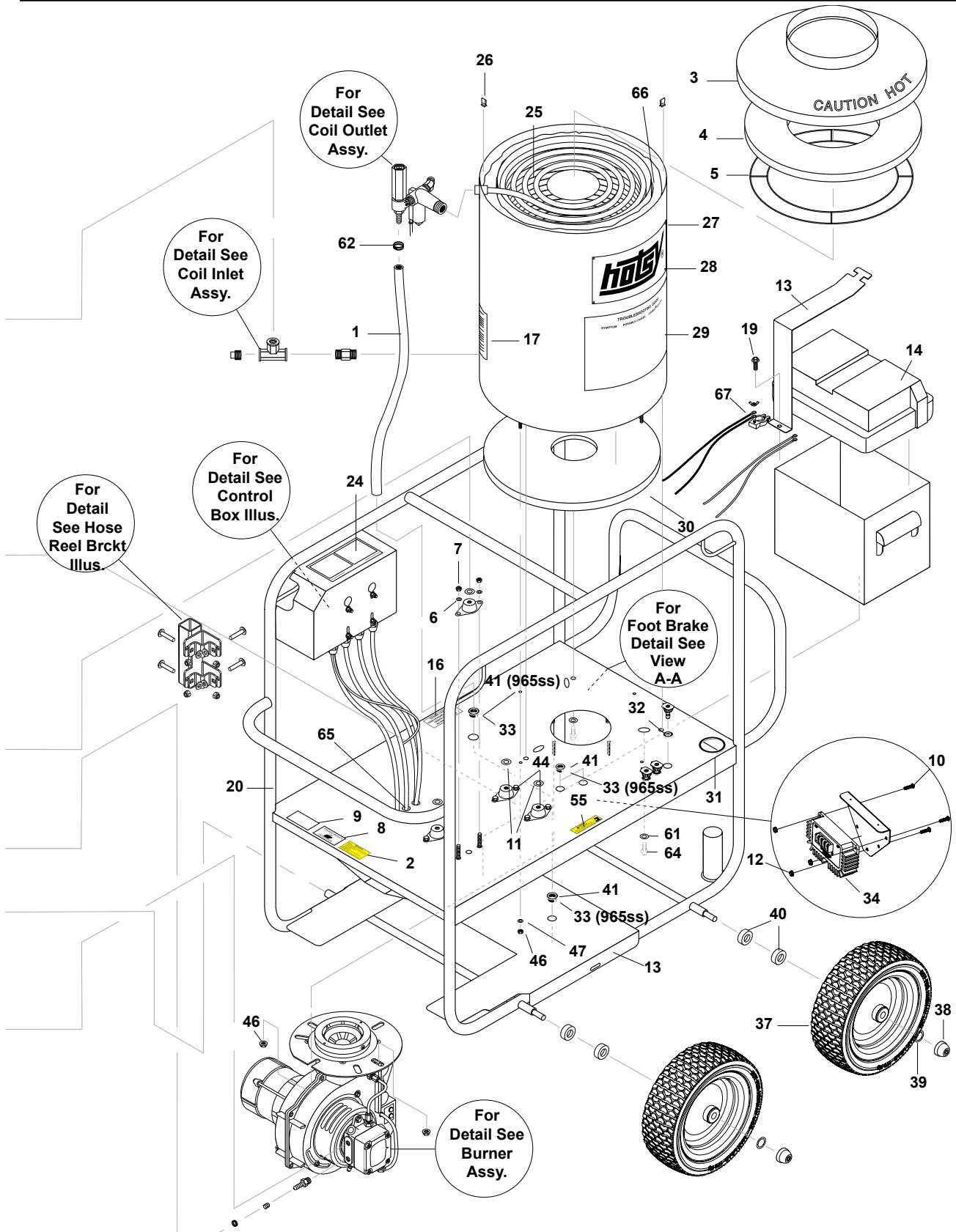

EXPLODED VIEW PARTS LIST

ITEM	PART NO.	DESCRIPTION	QTY	ITEM	PART NO.	DESCRIPTION	QTY
1	8.711-785.0	Hose, 3/8" Push On	38"	41	8.706-744.0	Plug, plastic 1'	2
2	9.800-049.0	Label, Manufacturers Cleaning Solution	1	42	8.759-215.0	Engine Honda GX270 E/S 18A 2021 NONCARB (965SS)	1
3	8.719-913.0	Top Hat, Weld Assy, 16"	1		8.759-216.0	Engine Honda GX340 18A 2021 NONCARB (1065SS)	1
4	9.802-904.0	Insulation Top head 16" x 8"	1		8.759-217.0	Engine GX340 E/S 18A 2021 NONCARB (1065SSE)	1
5	9.803-108.0	Ring, Insul Retainer, 16"	1		8.759-122.0	Engine Honda GX390 E/S 18A 2021 NONCARB(1075SSE)	1
6	8.718-980.0	Washer, 5/16" Flat Sae	8		8.759-118.0	Engine Vanguard 14HP E/S20A (965SS CAL, 1065SSE CAL, 1075SSE CAL)	1
7	9.802-776.0	Nut, 5/16, Esna, Nc	8	43	8.901-118.0	Tag, Gasoline Engine	1
8	8.901-172.0	Label, Detergent Metering	1	44	8.932-992.0	Mount , Vibration, 3/8" Rubber 70 Dura	4
9	8.901-136.0	Label, Use Hotsy Detergent	1	45	9.802-728.0	Bolt, 3/8-16 x 2", Hh Zinc	4
10	9.802-771.0	Screw, 10/32" x 3/4" (1065SSE,1075SSE)	2	46	9.802-776.0	Nut, 5/16, Esna, Nc	8
		(965SS,1065SS)	3	47	9.198-014.0	Washer 21/64 x 1"	4
11	9.802-809.0	Washer, 1/2" Flat Sae	4	48	8.912-017.0	Lever, Brake, Red	1
12	9.802-695.0	Nut, 10/32" Keps (1065SSE,1075SSE)	2	49	8.912-020.0	Linkage, Brake, Red	1
		(965SS,1065SS)	3	50	8.912-019.0	Bracket, Brake Pad, Red	1
13	8.920-175.0	Battery Bracket (Battery Models Only)	1	51	9.802-705.0	Bolt, 1/4-20 x 1", Carriage, Zinc	4
14	8.905-699.0	Box, Battery (Battery Models Only)	1	52	9.802-773.0	Nut, 1/4-20 Esna Nc	4
15	8.718-582.0	Bolt, 1/4-20 X 1/2", NC HH	2	53	9.198-004.0	Washer, 3/8" Flat Zinc	4
16	8.901-135.0	Label, Caution Winterize	1	54	9.802-814.0	Washer, 3/8" Split Ring Lock, Zinc	4
17	8.900-285.0	Label, Warning Pictorial	1	55	9.800-018.0	Label, Tip Over Hazard	1
18	9.802-768.0	Screw, 3/8" x 1-1/4", Whiz Loc Flange	4	56	8.706-321.0	Cap, Pipe, 1/8" Npt Brass	1
19	9.802-754.0	Screw, 1/4" x 1/2" Nc, Whiz Loc Flange	1	57	8.757-201.0	Hose Barb, 1/4" Barb x 1/8" M-NPTF	1
	8.929-530.0	1075BD frame painted	1	58	6.390-126.0	Clamp, Hose, .46-, .54 St	2
20	8.911-826.0	Chassis	1	59	9.802-254.0	Hose, 1/4" Push On	3"
	8.911-825.0	Chassis (965SS Only)	1	60	8.757-199.0	Hose Barb, 1/4" Barb x 1/4" M-NPTF,BRASS	1
21	8.901-157.0	Label, Important: Battery	1	61	9.802-819.0	Washer, 7/16" X 2 1/2", Zinc, PG Foot	3
22	8.901-127.0	Label, Caution, Gasoline	1	62	8.709-117.0	Clamp, Hose, Uni .62-.75 St	1
23	8.901-133.0	Label, Warning, Carbon Monoxide	1	63	9.802-959.0	▲ Key, 0.247 Sqr x 2.125"	1
24	8.901-206.0	Label, Hww Geng Instr	1	64	9.802-710.0	Screw 5/16" x 1"NC	3
25	8.925-218.0	Spare Coil Assy Hotsy 790 MTY	1	65	8.706-731.0	Bushing, 3/4"	2
	8.925-219.0	Spare Coil Assy Hotsy 555 MTY	1	66	8.717-438.0	Insulation Blanket 22" x 52" (1065SS, 1065SSE, 1075SSE)	1
26	9.802-825.0	Clip, Retaining U-Type	4		9.802-908.0	Insulation Blanket 18" x 52" (965SS)	1
27	8.911-802.0	Coil Wrap (965SS Only)	1	67	8.716-608.0	Terminal, Battery, Marine (Battery Models Only)	2
	8.911-800.0	Coil Wrap	1	68	8.760-611.0	Terminal cover medium red (1075SSE only)	1
28	8.704-654.0	Label, Hotsy Logo Red	2	69	9.804-615.0	Cover, Battery Terminal, Red (965SS CAL, 1065SSE CAL, 1075SSE CAL)	1
29	8.901-171.0	Label, Troubleshooting	1			▲Not Shown	
30	9.802-903.0	Insulation Bottom 16"	1				
31	9.803-544.0	Grommet	1				
32	9.802-064.0	Grommet (Nozzle Holder)	3				
33	9.802-104.0	Bushing, 1" Snap (965SS)	2 3				
34	77-31620-2GS-003	Voltage Reg (1065SSE, 1075SSE)	1				
	9.802-531.0	Voltage Reg. (965SS, 1065SS)	1				
35	8.706-937.0	Reducer, M12 To 1/4" F	1				
36	9.802-802.0	Washer, Flat 1/4	14				
37	8.758-460.0	Wheel 12 In. Rim Steel	4				
38	9.182-506.0	Cap Black Plastic, 5/8"	4				
39	8.718-870.0	Nut, .61 Id, Push Flat	4				
40	8.751-374.0	Spacer 5/8 X 1,25 Black	8				

1075BE COMPACT- POWER PLATFORM ASSY

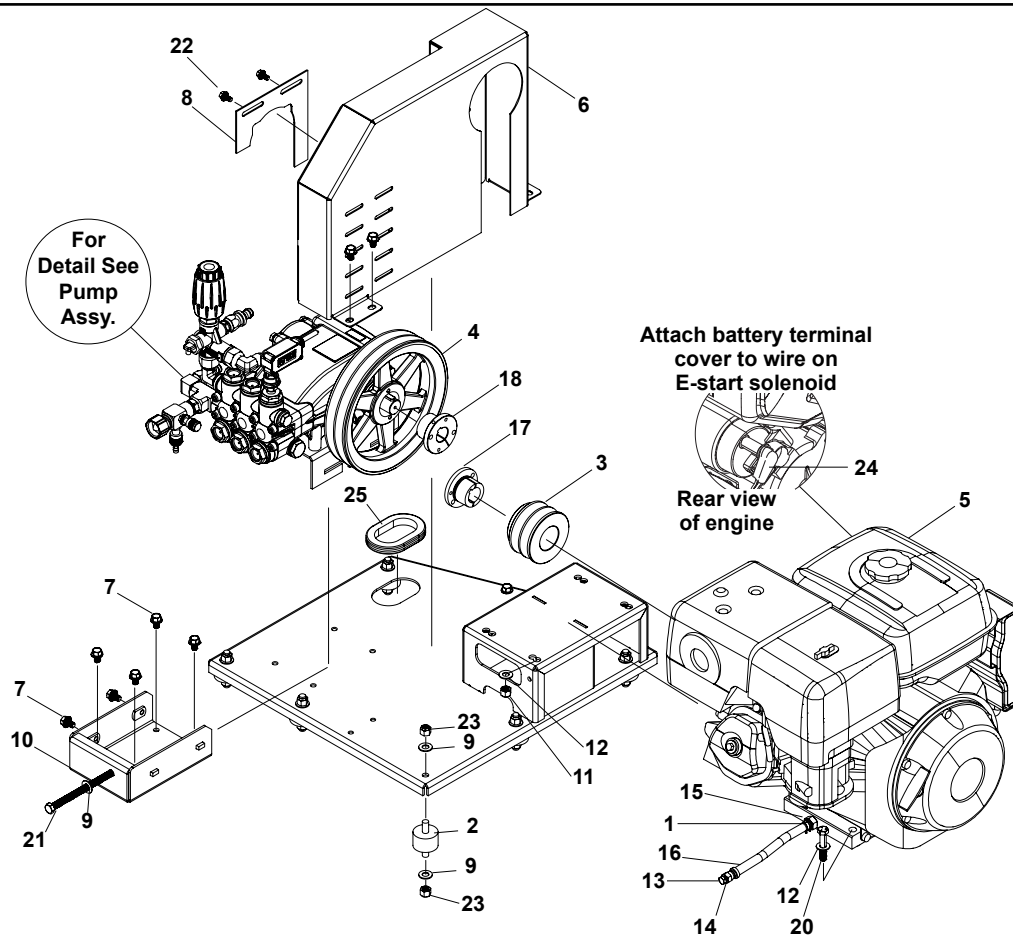

1075BE COMPACT-POWER PLATFORM ASSY PARTS LIST

ITEM	PART NO.	DESCRIPTION	QTY	ITEM	PART NO.	DESCRIPTION	QTY
1	6.390-126.0	Clamp Hose 0.46 - 0.54 ST	1	14	9.802-153.0	Swivel, 1/4" JIC FEM, Push-on	1
2	8.706-553.0	Mount, Rubber 60 Duro	7	15	9.802-154.0	Plug, Push-on, Oil Drain, Honda	1
3	8.715-576.0	Pulley, 2BK 32 H	1	16	9.802-254.0	Hose, 1/4" Jic FEM, Push-On	1.25
4	8.715-593.0	Pulley, 2BK 90 H	1	17	9.802-399.0	Bushing, H X 1	1
5	8.759-122.0	Engine Honda GX390 E/S 18A 2021 NONCARB (1075BE)	1	18	9.802-402.0	Bushing, H X 24MM	1
	8.759-118.0	Engine Vanguard 14HP E/S 20A (1075BE CAL)	1	19	9.802-415.0	Belt, BX35	2
6	8.929-527.0	Belt guard 1075BE painted	1	20	9.802-728.0	Bolt , 3/8-16 x 2", HH ZINC	4
7	9.803-277.0	Screw, 5/16" x 1/2", Whiz Loc Flange	10	21	9.802-735.0	Bolt, 3/8" x 5-1/2", NC HH TAP	1
8	8.929-529.0	Plate Belt Guard Painted	1	22	9.802-754.0	Srew , 1/4" x 1/2" NC, Whiz Loc Flange	2
9	9.198-004.0	3/8 USS F/W ZINC	15	23	9.802-779.0	Nut, 10/32" KEPS	14
10	8.930-817.0	Base pump slider right black	1	24	9.804-615.0	Cover, Battery Terminal, Red (1075BE COMPACT, 1075BE COMPACT CAL)	1
11	9.197-003.0	3/8-16 NE Nylon insert L/N ZC 5UM WHITE	4	25	9.803-545.0	Grommet, 2-5/16" Rubber, Cab Washer,P/N80	4
12	9.198-004.0	3/8 USS F/W ZINC	8				
13	9.802-125.0	Plug 1/4" JIC	1				

▲Not Shown

CONTROL PANEL ASSEMBLY EXPLODED VIEW & PARTS LIST

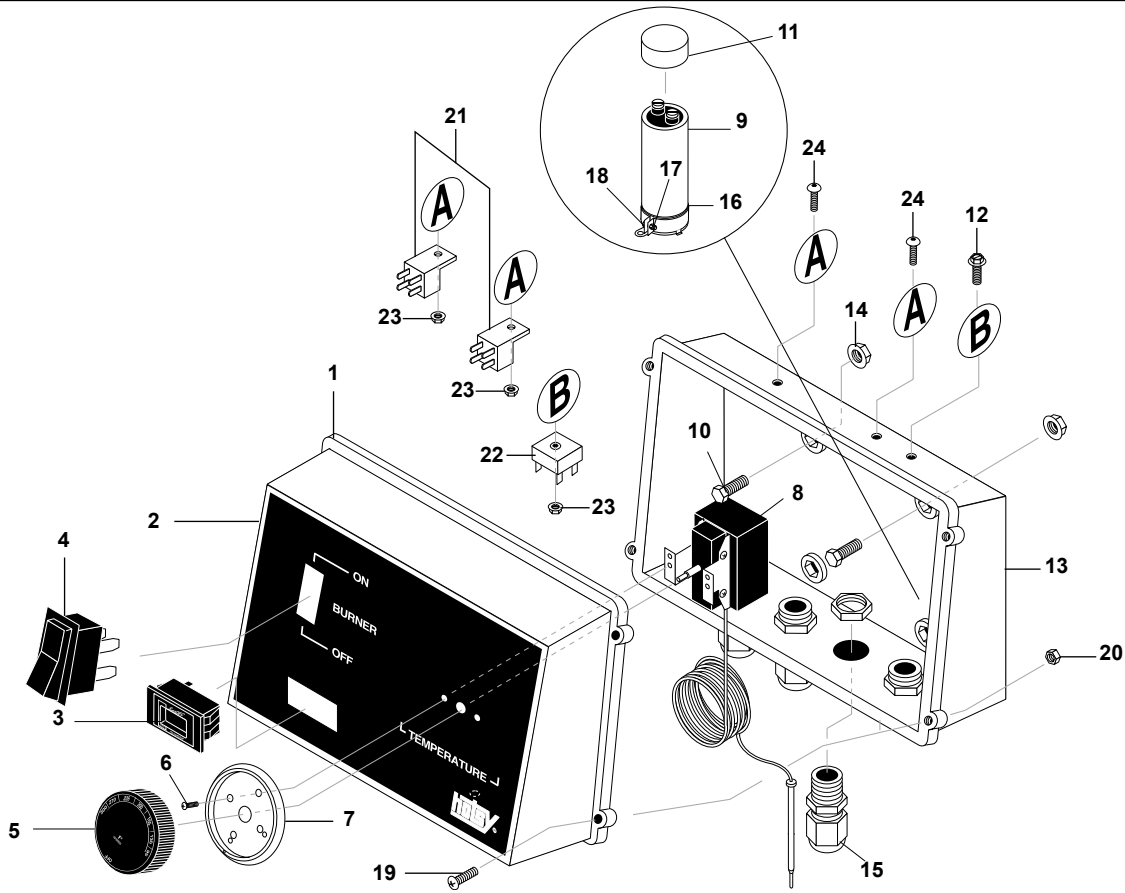

CONTROL PANEL ASSEMBLY PARTS LIST

ITEM	PART NO.	DESCRIPTION	QTY	ITEM	PART NO.	DESCRIPTION	QTY
1	8.719-947.0	Box, Plastic, Front	1	16	9.802-206.0	Clamp, (965SS,1065SS)	1
2	8.900-924.0	Label, Control Box	1	17	8.718-582.0	Bolt, 1/4-20 x 1/2", Nc Hh (965SS, 1065SS)	1
3	9.802-283.0	Hour Meter, 24-240 Vac 50/60 Hz	1	18	9.802-775.0	Nut, 1/4" Flange, Zn	1
4	8.716-036.0	Switch, Rocker, 15A/12V, Lt	1		8.759-757.0	▲Fuse ATC 20 Amp	1
5	8.750-097.0	Knob, Thermostat 120C/248F	1		8.716-223.0	▲Holder, Fuse	1
6	8.718-779.0	Screw, 4mm x 6mm, Pan Head	2		8.706-745.0	▲Plug Plastic 0.812	1
7	8.712-190.0	Bezel, Plastic, Thermostat	1	19	9.803-249.0	Screw, M4 x 10 (965SS, 1065SS) (1065SSE, 1075SSE)	5
8	8.750-095.0	Thermostat, 120C/240F 2 Meter Capillary	1	20	9.803-250.0	Nut (965SS, 1065SS) Nut (1065SSE, 1075SSE)	5
9	9.802-528.0	Capacitor (965SS, 1065SS)	1				6
10	8.718-596.0	Bolt, 1/4-14 x 3/4 Grd 5 PL Hex	4	21	9.802-470.0	Relay, 12V	2
11	9.803-048.0	Cap, Capacitor (965SS,1065SS)	1	22	8.716-622.0	Rectifier, Bridge (1065SSE, 1075SSE, 965SS CAL, 1065SSE CAL)	1
12	9.802-764.0	Screw, 10/32 X 3/4, Hex Wash SI Mach/Blk	1	23	9.802-695.0	Nut 10/32" KEPS	3
13	9.802-480.0	Back Box		24	9.802-759.0	Screw, 10/32" x 1/2" BHSOC BLK	2
14	9.802-773.0	Nut, 1/4-20 Esna Nc	4			▲Not Shown	
15	9.802-514.0	Strain Relief, Lt, Str, 1/2 Npt .23-.45D	3				

FUEL TANK ASSEMBLY AND PARTS LIST

ITEM	PART NO.	DESCRIPTION	QTY
1	8.757-732.0	Label, Fuel Type	1
2	8.931-594.0	Fuel tank 8 Gal Hotsy	1
3	9.803-535.0	Cap With Fuel Display	1
4	9.802-254.0	Hose, 1/4" Push On	19"
5	8.912-133.0	Elbow 1/4" Hose Stand Pipe 90 Deg	1
6	9.802-053.0	Bushing, Fuel Line, Rubber	2
7	9.802-141.0	Hose Barb 1/4" Barb x 3/8" Barb, Dou	1
8	6.390-126.0	Clamp, Hose, .46-.54 St	2
9	9.802-254.0	Hose, 1/4" Push On	19"
10	8.750-933.0	Band Hose Clamp	2
11	8.758-512.0	Label max biodiesel	1

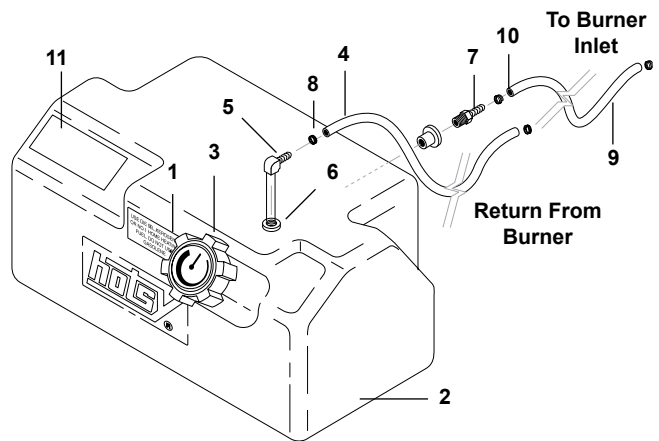

HOSE, SPRAY GUN & WAND ASSEMBLY AND PARTS LIST

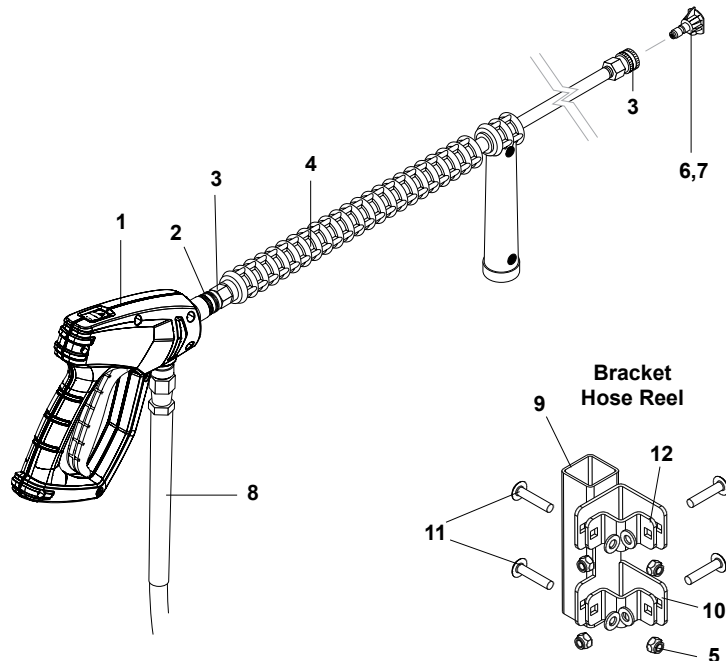

ITEM	PART NO.	DESCRIPTION	QTY
1	4.760-845.0	Trigger gun Classic G3/8 155°C Hotsy	1
2	8.707-139.0	Coupler, 1/4" Plug, M, S/Z	1
3	9.802-164.0	Coupler, 1/4" Socket, F, B	2
4	8.725-388.0	Wand, Single, 48" Insulated	1
5	9.802-776.0	Nut, 5/16, Esna, Nc	4
6	8.712-346.0	Nozzle, 1504 Yellow ,(1060SS 1 ,1065SS,1065SSE, 1075SSE)	1
	8.712-338.0	Nozzle, 1503.5 Yellow (965SS)	1
7	8.712-348.0	Nozzle, 4004 White (1065SS, 1065SSE,1075SSE)	1
	8.712-340.0	Nozzle, 4003.5 White (965SS)	1

ITEM	PART NO.	DESCRIPTION	QTY
8	8.925-130.0	Hose, 3/8" X 50' 1W 4000PSI SW/SO/CPL	1
9	8.931-243.0	Bracket Hose Reel	1
10	8.915-292.0	Bracket Hose Reel Retainer	2
11	8.718-623.0	Bolt, 5/16"-18 x 1-1/2" Nc Crge Zinc	4
12	8.718-980.0	Washer, 5/16" Flat, Sae	4
13	9.802-776.0	Nut, 5/16, Esna, Nc	4

REPLACEMENT PARTS

	8.717-661.0	Grip, Handle Assy, Hotsy	1
	8.706-670.0	Grip, Wand Side Handle	1
	8.751-119.0	Kit, Gun Repair	1

BURNER ASSEMBLY EXPLODED VIEW

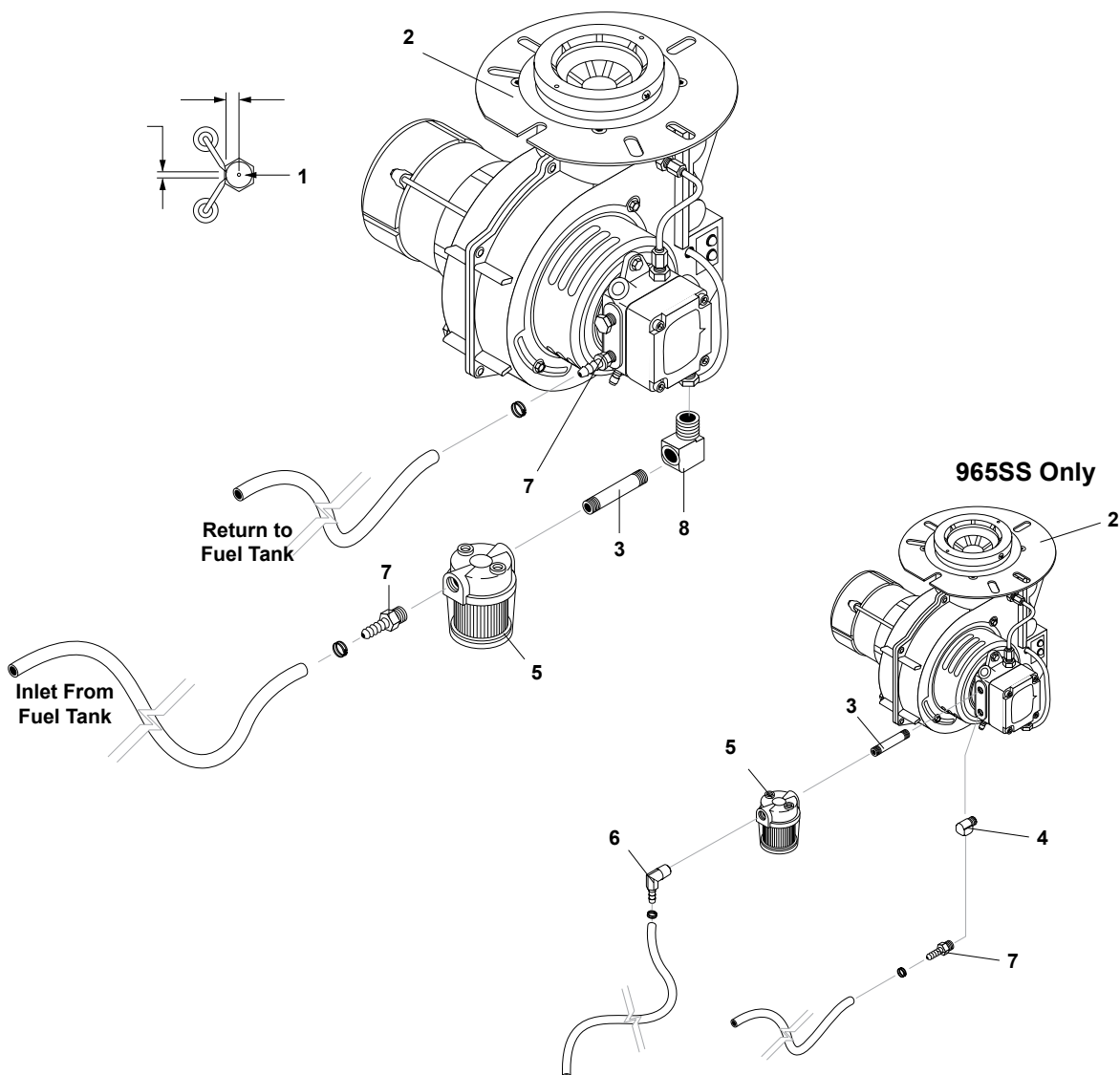

BURNER ASSEMBLY PARTS LIST

ITEM	PART NO.	DESCRIPTION	QTY	ITEM	PART NO.	DESCRIPTION	QTY
1	8.756-723.0	Fuel Nozzle, 1.50 x 80 BZ (965SS Only)	1	6	8.757-205.0	Hose Barb, 1/4" Barb x 1/4" M-NPTF, 90°	1
	8.700-970.0	Fuel Nozzle 1.75 X 90 A	1	7	8.757-199.0	Hose Barb 1/4" Barb x 1/4" MNPTF Brass	1
2	8.759-484.0	Burner ADC 14VDC 60HZ 12VDC F22 VRT	1	8	8.757-339.0	Elbow, 1/4" Street 90 Deg, Steel W/SLNT	1
3	8.757-366.0	Nipple, 1/4" X 3", W/SLNT	1	REPLACEMENT PARTS			
4	8.757-198.0	Elbow 1/4" Street Brass	1	8.717-711.0	Screen, Fuel Filter	1	
5	8.757-652.0	Filter Fuel Hotsy 1/4" female	1				

BECKETT BURNER EXPLODED VIEW

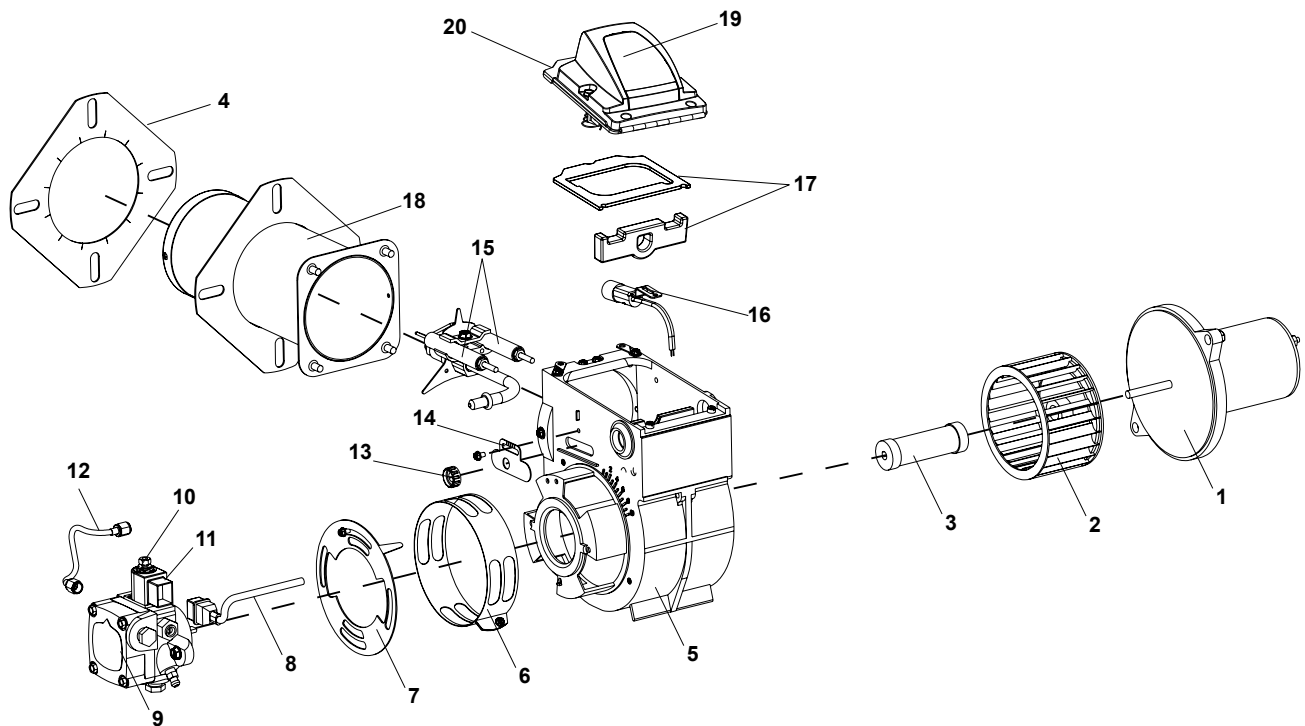

BECKETT BURNER PARTS LIST

ITEM	PART NO.	DESCRIPTION	QTY	ITEM	PART NO.	DESCRIPTION	QTY
1	9.802-638.0	Burner Motor, 13.5V, 3450RPM, 1/6 HP	1	13	9.802-657.0	Escutcheon Plate Spline Nut	1
2	9.802-649.0	Blower Wheel 4.25x2.5 AFG/Turb	1	14	8.750-491.0	Escutcheon Plate	1
3	9.802-648.0	Coupling	1	15	9.802-670.0	Electrode Kit Over 3-5/8"	1
4	8.717-899.0	Flange Mounting Gasket	1	16	8.718-147.0	Cad Cell Detector	1
5	9.802-671.0	Burner Housing - Black	1	17	9.805-662.0	Igniter Gasket Kit	1
6	8.701-074.0	Bair Band #3492 Afg ADC	1	18	8.760-398.0	ATC AF35YFDC23	1
7	8.701-077.0	Air Shutter - 8 Slot	1	19	8.751-788.0	Igniter Only	1
8	9.802-643.0	Cord Set	1	20	8.751-785.0	Igniter Assy With Baseplate	1
9	8.760-331.0	Pump (Cleancut)	1		8.723-715.0	▲Tune-Up Kit For 30 & 35 Air Tube Lengths	1
10	9.802-646.0	Valve Stem	1			▲Not Shown	
11	9.802-643.0	12 Volt Coil	1				
12	9.802-667.0	8" Copper Tubing	1				

WAYNE BURNER PARTS LIST

Replacement Parts

For best performance specify genuine WAYNE replacement parts

ITEM	PART NO.	DESCRIPTION	QTY
1	8.756-678.0	Tube/Hous-101407-001/3A/.88I	1
2	8.756-731.0	Gun-RG/*CST/GBB	1
3	8.756-437.0	Pump-s A2VA3006-N261 12V Combo	1
4	8.700-704.0	Oil Line ASM-6"	1
11	8.759-129.0	Plate Slot Cover	1
12	8.700-681.0	Nut, Hex 3/8-24 CRZC	1
15	8.700-732.0	Band, Air-Inner E/FH	1
16	8.700-729.0	Band, Air-Outner 8-Hole E/F	1
18	8.759-194.0	▲Post, contact-Allason	2
23	8.756-741.0	Cover, Juntion Box	1
26	8.756-716.0	Motor, 13.5VDC-Ametek	1
27	8.759-195.0	Cover, Hous-E 12V	1
28	9.107-507.0	Ignitor-CC 6385 12VDC 4.8A	1
29	9.109-124.0	Base, Mounting-Ignitor CC Timer	1
30	8.756-661.0	Timer, Ignitor-12V AH1501	1
35	8.700-819.0	▲CAD, Cell-H 15" LEAD/17* BRKT	1
37	8.756-730.0	▲Fan-3.44"W X 4.75"D 5/16" Bore	1
38	8.756-715.0	▲Coupling-Mod E 12VDC	1
50	8.700-692.0	*Gasket, Flange-STD Large	2

▲Not Shown

Packed with burner

PUMP ASSEMBLY - 965SS

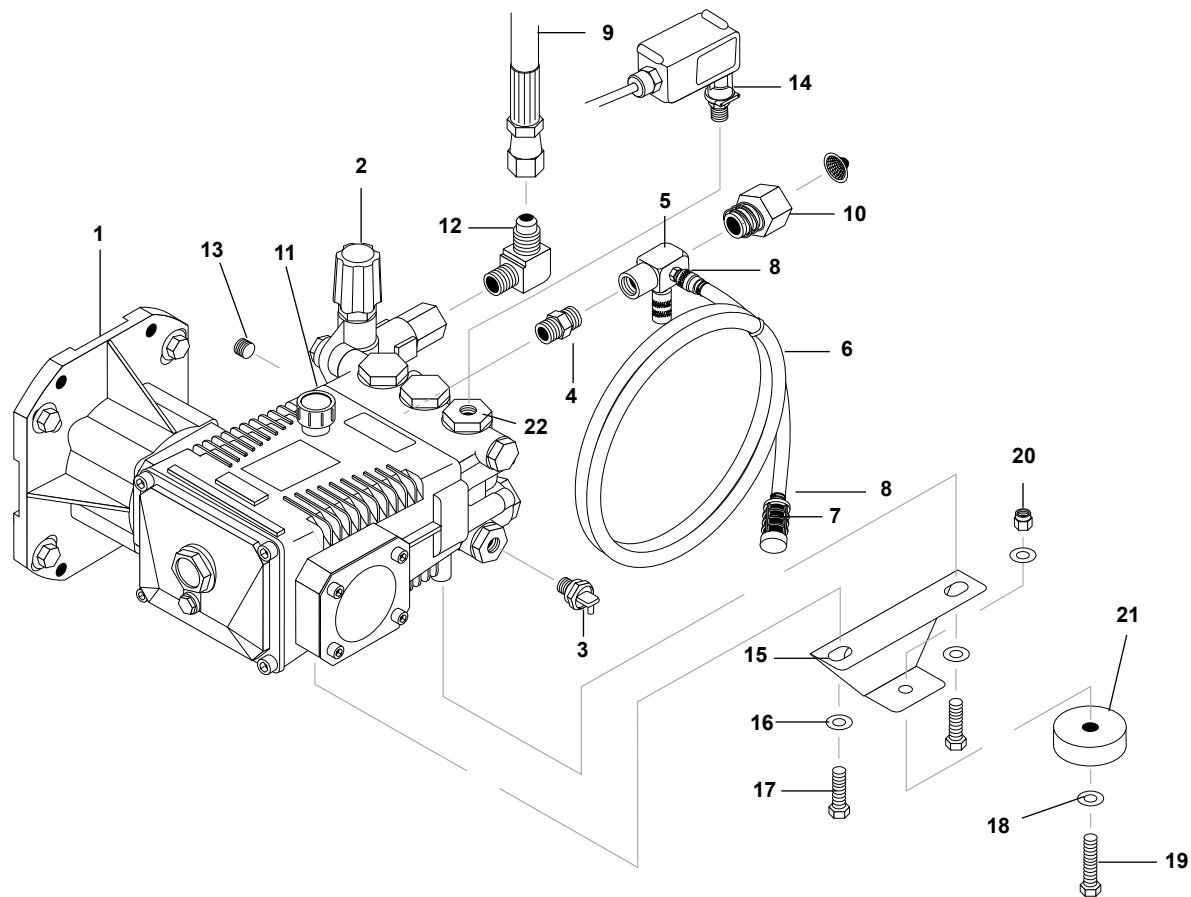

PUMP ASSEMBLY PARTS LIST

ITEM	PART NO.	DESCRIPTION	QTY	ITEM	PART NO.	DESCRIPTION	QTY
1	8.929-272.0	Pump LEUCO LPP3035G1, 3.0@3500, 3400RPM (8.758-075.0)	1	14	9.802-458.0	Switch, Pressure N/O, 1/4 Npt SS	1
2	8.754-696.0	Unloader, VBT Banjo 1/2M 3/8M, 3000 PSI	1	15	9.804-533.0	Rail, Pump Support	1
3	8.757-549.0	Pump protector 1/2 140°	1	16	8.718-980.0	Washer, 5/16" Flat Sae	1
4	8.706-880.0	Nipple, 1/2" Mpt x 3/8" Mpt, Brass	1	17	9.802-741.0	Bolt, 8mm x 16mm, Hex Head	2
5	9.803-275.0	Injector, Adjustable, Inlet	1	18	9.802-817.0	Washer, 3/8"x 1"	2
6	9.802-252.0	Hose, 1/4" x 1/2" Braided Vinyl	4 ft.	19	9.802-722.0	Bolt, 3/8" x 1-1/4", Nc Hh	1
7	8.707-056.0	Strainer, Chemical W/ 1/4 Brass Barb	1	20	9.197-003.0	Nut, 3/8"-16 Nylon Insert	1
8	6.390-126.0	Clamp, Hose, .46-.54 St	2	21	9.802-066.0	Pad, Soft Rubber	1
9	8.918-424.0	Hose, 3/8" x 25", 2 Wire, Press Loop	1	22	9.804-022.0	Cap, Valve 22m, 1/4"Gauge	1
10	9.802-147.0	Swivel, 3/8" Mp x 3/4" Ghf W/ Strainer	1				
11	9.803-957.0	Oil Dipstick	1				
12	8.757-935.0	Adapter steel 1/2 JIC x 3/8 NPTF (F) 90°	1				
13	8.757-192.0	Plug, 1/4" Nptf Countersunk Brass	1				

PUMP ASSEMBLY - 1065SS, 1065SSE, 1075SSE

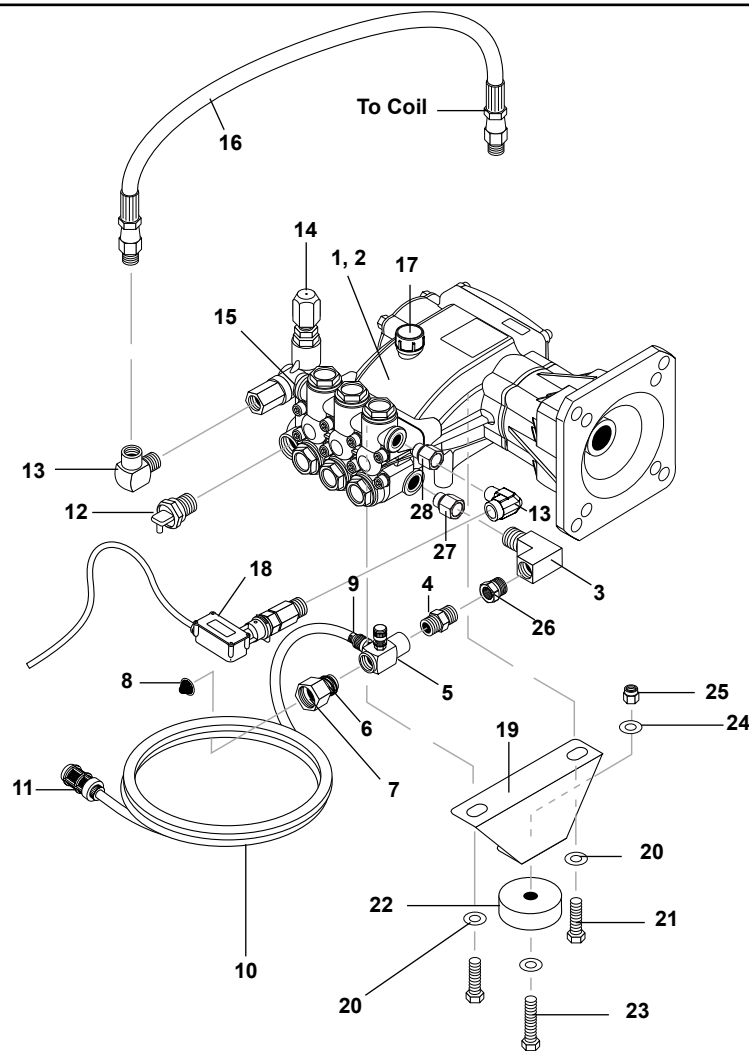

PUMP PARTS LIST - 1065SS, 1065SSE, 1075SSE

ITEM	PART NO.	DESCRIPTION	QTY	ITEM	PART NO.	DESCRIPTION	QTY
1	8.751-183.0	Pump (1065SS,1065SSE)	1	16	8.918-218.0	Hose, 3/8" x 29", 2 Wire, 3/8M. Sol x 1/2	1
2	8.751-184.0	Pump (1075SSE)	1	17	9.802-921.0	Oil Dipstick	1
3	8.757-342.0	Elbow, 1/2" Street, Brass	1	18	8.716-125.0	Switch, Pressure, 3/8" NPT Brass, 65" (1065SSE)	1
4	8.706-880.0	Nipple, 1/2" Mpt x 3/8" Mpt	1		8.704-196.0	Switch, Pressure Hp, Red 5800 Psi (1075SSE)	1
5	9.803-275.0	Injector, Adjustable, Inlet	1	19	8.933-024.0	Rail, Pump Support	1
6	8.718-492.0	Spring, .95 x .055 x .6	1	20	9.802-816.0	Washer, 7/16" Split Ring Lock	2
7	9.802-147.0	Swivel, 3/8" Mp x 3/4" Ghf	1	21	9.802-744.0	Bolt, 10mm x 20mm, Hh Zc	2
8	9.804-016.0	Filter Screen Washer, Garden Hose/Mesh	1	22	9.802-066.0	Pad Soft Rubber	1
9	6.390-126.0	Clamp, Hose, .46-.54 St	2	23	9.802-722.0	Bolt, 3/8" x 1-1/4", Nc Hh	1
10	9.802-252.0	Hose, 1/4"x 1/2", Braided	48"	24	9.802-817.0	Washer, 3/8" x 1"	1
11	8.707-056.0	Strainer, Chemical W/ 1/4 Brass Barb	1	25	9.197-003.0	Nut, 3/8"-16 Nylon Insert	1
12	8.757-549.0	Pump protector 1/2 140°	1	26	8.757-193.0	Adapter, 1/2" F-NPTF x 1/2" M-NPTF, Brass (Brass)	1
13	8.757-340.0	Elbow 3/8", Street 90 Deg, Steel, W/SLNT	2	27	8.757-193.0	Adapter, 1/2" F-NPTF x 1/2" M-NPTF, Brass	1
14	9.803-900.0	Unloader, VBA	1	28	8.757-184.0	Adapter steel 3/8 NPTF(F) x 3/8 BSPP(M)	1
15	8.901-117.0	Tag, Warning Unloader	1				

PUMP ASSEMBLY - 1075BE COMPACT

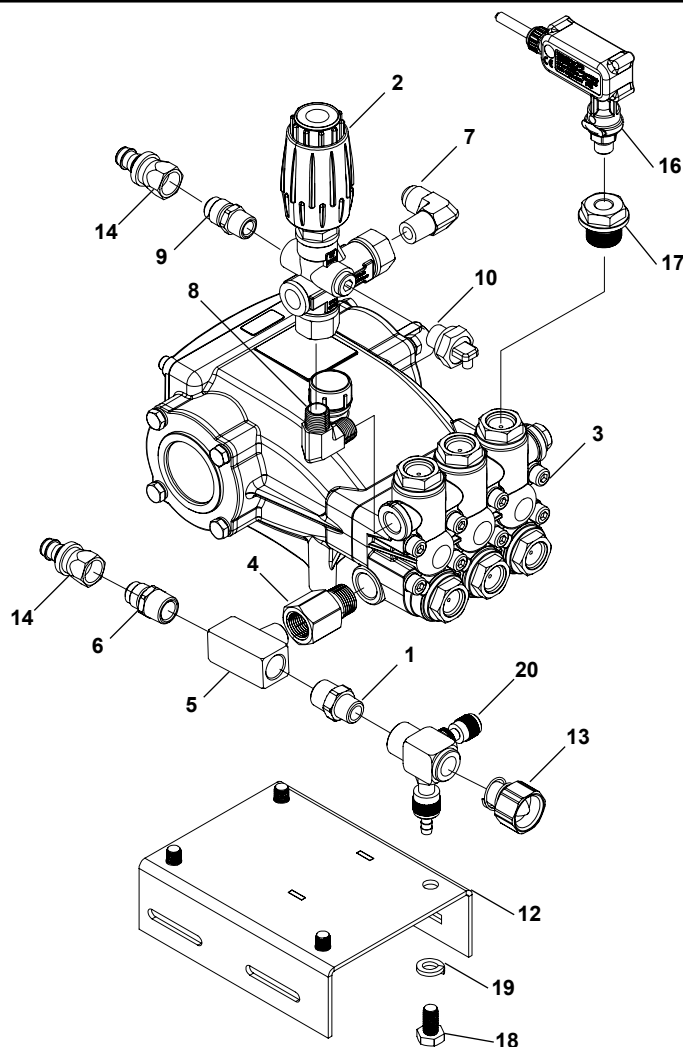

PUMP PARTS LIST - 1075BE COMPACT

ITEM	PART NO.	DESCRIPTION	QTY	ITEM	PART NO.	DESCRIPTION	QTY
1	8.706-880.0	Nipple, 1/2" MPT x 3/8" MPT Brass	1	11	8.930-815.0	Slider pump mount right black	1
2	8.750-299.0	Unloader VRT3, 8 GPM @4500 PSI	1	12	9.802-147.0	Swivel, 3/8" MP X 3/4" GHF W/Strainer	1
3	8.751-180.0	Pump Hotsy HM4035R.3, 4.8@3500 1500 RPM	1	13	9.802-151.0	Swivel, 1/2" BARB x 1/2" JIC, FEM/BRASS	2
4	8.757-193.0	Adapter, 1/2" F-NPTF x 1/2" M-NPTF, BRASS	1	14	9.802-259.0	HOSE, 1/2" PUSH-ON, /FT	1.3
5	8.757-345.0	Tee, 1/2" Branch Male, Brass	1	15	9.802-458.0	Switch PRESSURE N/O, 1/4 NPT SS	1
6	8.757-200.0	Adapter brass 1/2 SAE (M) x 1/2 NPTF (M)	1	16	9.802-632.0	CAP, Valve 24MM, W/ 1/4" GAUGE PORT	1
7	8.757-340.0	Elbow 3/8", Street 90 DEG, Steel, W/SLNT	1	17	9.802-744.0	BOLT, 10mm x 20mm, HH ZINC 1	4
8	8.758-007.0	Adapter brass 1/2 JIC (M) x 3/8 NPTF (M)	1	18	9.802-816.0	Washer, 7/16", Split Ring LOCK, 780481	4
9	8.758-203.0	Protection Pump 3/8" 145 Deg w/sint	1	19	9.803-275.0	Injector, Adjustable, INLET, HOTSY	1
10	8.918-218.0	Hose, 3/8"X 29",2 WIRE, 3/8M.SOL X 1/2M	1	20	8.757-511.0	Elbow, 3/8", STEEL	1

COIL INLET ASSEMBLY

965SS (Only)

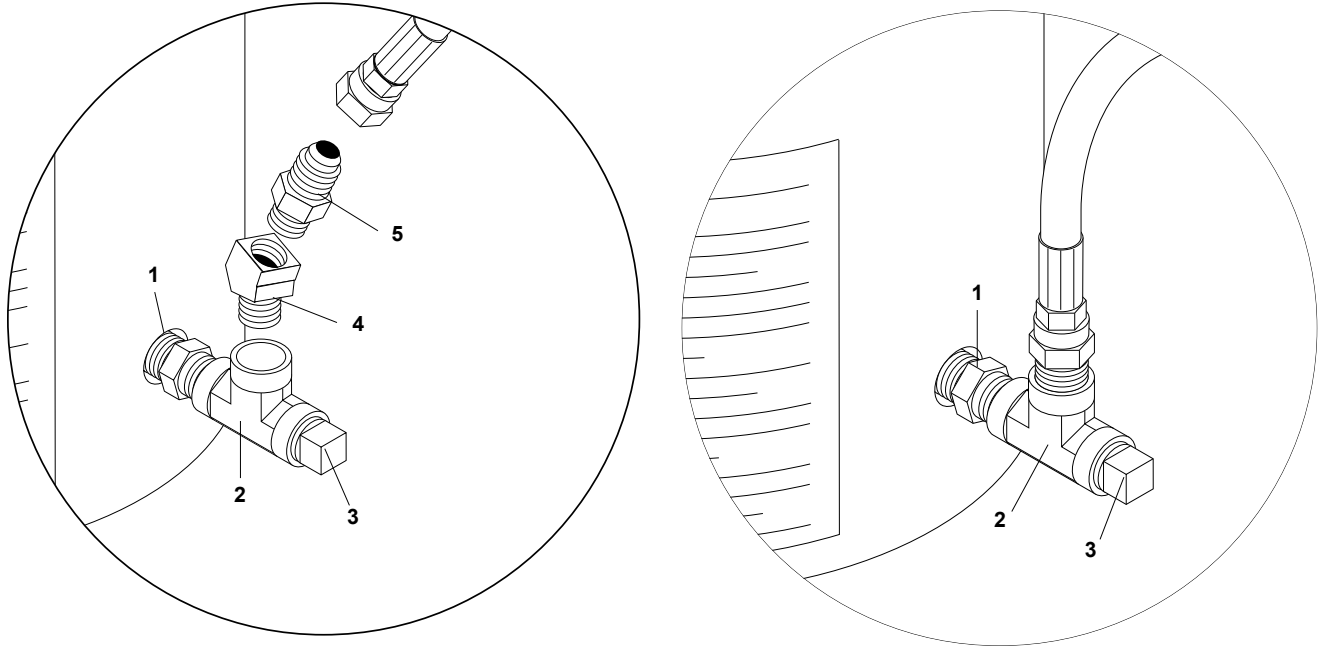

COIL INLET PARTS LIST

ITEM	PART NO.	DESCRIPTION	QTY
1	8.757-653.0	Nipple hex steel 3/8" NPTF x 3/8" BSPP (965SS)	1
	8.757-338.0	Nipple, 1/2" HEX Steel, W/SLNT (1065SS, 1065SSE, 1075SSE)	1
2	8.757-944.0	Tee steel 3/8 NPTF (F) (965SS)	1
	8.757-615.0	Tee steel 1/2" NPTF (F) (1065SS, 1065SSE, 1075SSE)	1
3	8.757-241.0	Plug 3/8 NPTF allen counter sunk w/slnt (965SS)	1
	8.757-625.0	Plug 1/2 NPTF square head (1065SS, 1065SSE, 1075SSE)	1
4	8.757-551.0	Elbow Street Steel 3/8" 45° (965SS)	1
5	8.757-655.0	Adapter steel 1/2 JIC (M) x 3/8 NPTF (M)	1

HS.3 PUMP EXPLODED VIEW

8.751-184.0 HS4040G.3
8.751-183.0 HS3040G.3

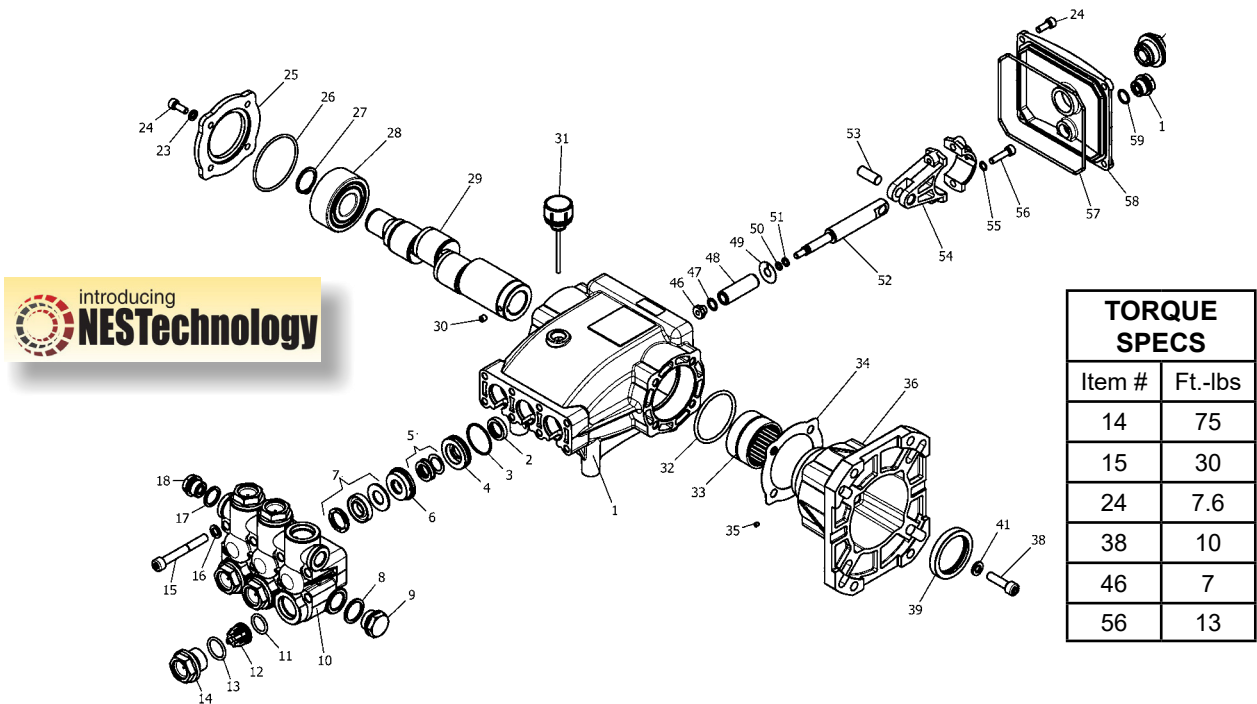

HS.3 PUMP EXPLODED VIEW PARTS LIST

ITEM	PART NO.	DESCRIPTION	QTY	ITEM	PART NO.	DESCRIPTION	QTY
1	8.751-217.0	Crankcase	1	26	8.717-225.0	O-Ring Ø 2.62 x61.6	1
2*	See Kit Below	Plunger Oil Seal	3	27	9.802-914.0	Snap Ring	1
3*	See Kit Below	O-Ring Ø1.78 x 31.47	3	28	9.803-168.0	Double Row Ball Bearing	1
4*	See Kit Below	Pressure Ring	3	29	9.803-150.0	Crankshaft (3040G.3)	1
5*	See Kit Below	U-Seal, 15mm	3		9.803-151.0	Crankshaft (3540G.3)	1
6*	See Kit Below	Intermed. Ring 15mm	3		9.803-152.0	Crankshaft (4040G.3)	1
7*	See Kit Below	U-Seal, 15mm	3		9.803-153.0	Crankshaft (5030G.3)	1
8	9.803-199.0	Copper Washer 1/2"	1	30	9.802-945.0	Set Screw	1
9	9.802-926.0	Brass Plug, 1/2"	1	31	9.802-921.0	Oil Dip Stick	1
10	8.751-218.0	Manifold Housing	1	32	9.804-581.0	O-Ring Ø 3.53 x 55.56	1
11*	9.803-191.0	O-Ring Ø2.62 x 17.13	6	33	9.803-161.0	Needle Roller Bearing	1
12*	See Kit Below	Valve Assembly	6	34	8.751-230.0	Gasket	1
13*	9.803-193.0	O-Ring Ø2.62 x 20.29	6	35	8.717-544.0	Screw, Set	1
14	9.802-928.0	Valve Plug	6	36	9.803-183.0	Engine Flange	1
15	9.802-938.0	Manifold Stud Bolt	8	38	9.803-240.0	Flange Screw	4
16	9.802-884.0	Washer	8	39	9.803-142.0	Crankshaft Seal	1
17	9.803-198.0	Copper Washer 3/8"	1	41	9.803-221.0	Spring Washer	4
18	9.802-925.0	Brass Plug 3/8"	2	46*	See Kit Below	Plunger Nut, M6	3
23	9.803-201.0	Washer, M6 x 16	4	47*	See Kit Below	Washer, Copper, 9.2 x 13.5	3
24	9.802-939.0	Hexagonal Screw	9	48*	See Kit Below	Plunger, 15mm	3
25	9.803-184.0	Closed Bearing Housing	1	49*	See Kit Below	Copper Spacer	3

HS.3 PUMP EXPLODED VIEW PARTS LIST

ITEM	PART NO.	DESCRIPTION	QTY
50*	See Kit Below	O-Ring Ø1.78x5.28	3
51*	See Kit Below	Teflon Ring	3
52	8.751-225.0	Plunger Rod	3
53	8.751-228.0	Connecting Rod Pin	3
54	9.803-158.0	Connecting Rod	3
55	9.803-218.0	Spring Washer	6
56	9.803-238.0	Connecting Rod Screw	6
57	8.933-016.0	O-Ring 2.62 x 126.67	1
58	8.751-229.0	Crankcase Cover	1
59	9.803-197.0	O-Ring, Ø 1.78 x 14	1
60	9.803-202.0	Sight Glass, G3/4	1

* Part available in kit (See below)

REPAIR KIT NUMBER	8.725-358.0	8.725-359.0	8.933-023.0	9.802-603.0	9.802-609.0
KIT DESCRIPTION	Plunger U-Seal 15mm	Complete U-Seal Packing 15mm	Plunger 15mm	Complete Valve	Plunger Oil Seals
ITEM NUMBERS INCLUDED	3, 5, 7	3, 4, 5, 6, 7	46, 47, 48, 49, 50, 51	11, 12, 13	2
NUMBER OF CYLINDERS KIT WILL SERVICE	3	1	1	6	3

HM.3 SERIES PUMP EXPLODED VIEW

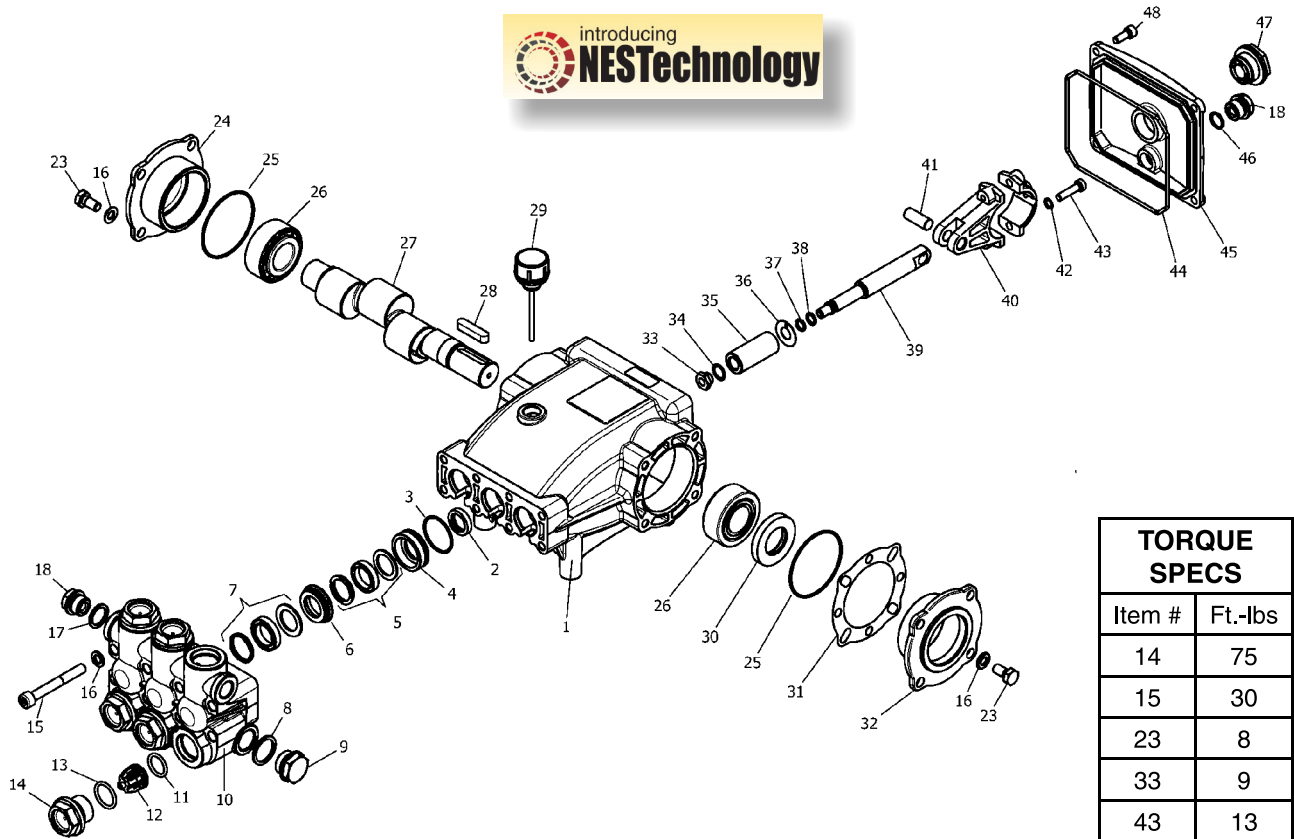

TORQUE SPECS	
Item #	Ft.-lbs
14	75
15	30
23	8
33	9
43	13
48	7.6

HM.3 SERIES PUMP PARTS LIST

ITEM	PART NO.	DESCRIPTION	QTY	ITEM	PART NO.	DESCRIPTION	QTY
1	8.751-216.0	Crankcase	1	24	8.717-210.0	Closed Bearing Housing	1
*2		Plunger Oil Seal	3	25	9.803-192.0	O-Ring Ø1.78 X 60.05	2
*3		O-Ring Ø1.78 X 31.47	3	26	8.933-011.0	Tapered Roller Bearing	2
*4		Pressure Ring	3	27	8.751-222.0	Crankshaft (3540)	1
*5		U-Seal	3		8.751-223.0	Crankshaft (4030, 4035)	1
*6		Intermediate Ring	3		8.717-063.0	Crankshaft (4031)	1
*7		U-Seal	3	28	9.803-167.0	Crankshaft Key	1
8	9.803-199.0	Washer, Copper	1	29	9.802-921.0	Oil Dip Stick	1
9	9.802-926.0	Plug, Brass 1/2	1	30	9.803-140.0	Crankshaft Seal	1
10	8.751-218.0	Manifold Head	1	31	9.803-178.0	Shim	2
*11		O-Ring Ø2.62 X 17.13	6	32	8.717-209.0	Bearing Housing	1
*12		Valve Assembly	6	*33		Plunger Nut, M8	3
*13		O-Ring Ø2.62 X 20.29	6	*34		Copper Spacer	3
14	9.802-928.0	Valve Plug	6	*35		Plunger	3
15	9.802-938.0	Manifold Stud Bolt	8	*36		Copper Spacer	3
16	9.802-884.0	Washer	16	*37		O-Ring	3
17	9.803-198.0	Copper Washer 3/8	1	*38		Teflon Ring	3
18	9.802-925.0	Brass Plug 3/8	2	39	8.751-224.0	Plunger Rod (4030, 4031, 4035)	3
23	9.802-944.0	Hexagonal Screw	8		8.751-225.0	Plunger Rod (3540)	3

HM.3 SERIES PUMP PARTS LIST

ITEM	PART NO.	DESCRIPTION	QTY
40	9.803-158.0	Connecting Rod	3
41	8.751-228.0	Connecting Rod Pin	3
42	9.803-218.0	Spring Washer	6
43	9.803-238.0	Connecting Rod Screw	6
44	70-060009	O-Ring, Ø2.62 X 126.67	1
45	8.751-229.0	Crankcase Cover	1
46	9.803-197.0	O-Ring, Ø1.78 X 14	1
47	9.803-202.0	Sight Glass 3/4	1
48	9.802-939.0	Cover Screw	5

*See Kits Table

HM.3 SERIES PUMP - REPAIR KIT NUMBERS

REPAIR KIT NUMBER	8.725-360.0	8.725-362.0	8.725-358.0	8.725-361.0	8.725-363.0	8.725-359.0
KIT DESCRIPTION	Plunger Seal 4035 18mm	Plunger Seal 4030, 4031 20mm	Plunger Seal 3540 15mm	Complete Seal Packing 4035 18mm	Complete Seal Packing 4030, 4031 20mm	Complete Seal Packing 3540 15mm
ITEM NUMBERS INCLUDED	3, 5, 7	3, 5, 7	3, 5, 7	3, 4, 5, 6, 7	3, 4, 5, 6, 7	3, 4, 5, 6, 7
NUMBER OF CYLINDERS KIT WILL SERVICE	3	3	3	1	1	1

REPAIR KIT NUMBER	8.751-237.0	8.751-238.0	8.933-023.0	9.802-603.0	9.802-609.0
KIT DESCRIPTION	Plunger 4035 18mm	Plunger 4030, 4031 20mm	Plunger 3540 15mm	Complete Valve	Plunger Oil Seals
ITEM NUMBERS INCLUDED	33, 34, 35, 36, 37, 38	3, 5, 7	33, 34, 35, 36, 37, 38	11, 12, 13	2
NUMBER OF CYLINDERS KIT WILL SERVICE	1	1	1	6	3

HPP3035G1 SERIES PUMP EXPLODED VIEW

8.929-272.0 HPP3035G1

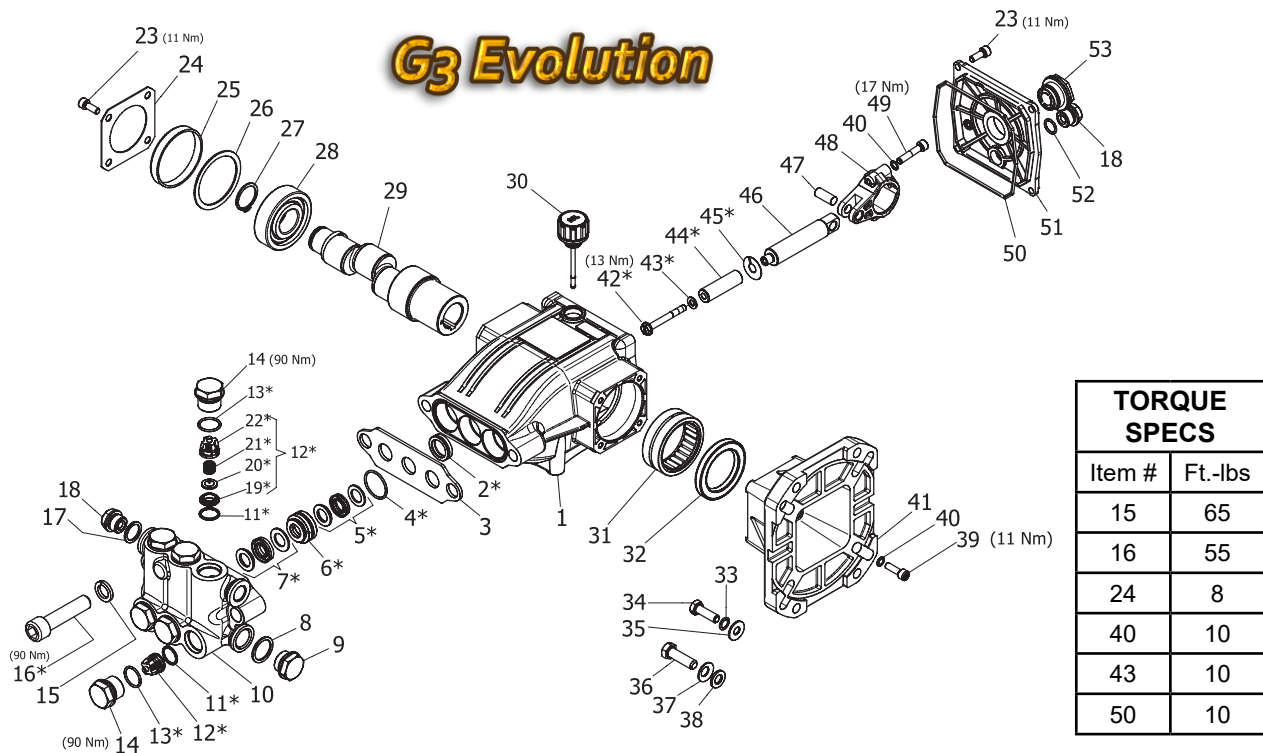

HPP3035G1 SERIES PUMP EXPLODED VIEW PARTS LIST

ITEM	PART NO.	DESCRIPTION	QTY	ITEM	PART NO.	DESCRIPTION	QTY
1	8.754-841.0	Crankcase	1	20	See Kits Below	Valve Plate	6
2*	See Kits Below	Plunger Oil Seal	3	21	See Kits Below	Valve Spring	6
3	8.758-216.0	Spacer	1	22	See Kits Below	Valve Cage	6
4	See kits below	O Ring 1.78x26.7	3	23	9.802-939.0	Screw, M6 X 16	8
5	See Kits Below	U-Seal, 14 mm	3	24	8.717-137.0	Bearing Cover	2
6	See Kits Below	Pressure Ring, 14 mm	3	25	9.803-954.0	Bearing Seal	1
7	See Kits Below	U-Seal, 14 mm	3	26	8.754-843.0	Seal Spacer, Crankshaft	1
8	9.803-199.0	Washer, Copper G1/2	1	27	9.802-914.0	Snap Ring, 25 mm	1
9	9.802-926.0	Plug, Brass G1/2	1	28	9.803-955.0	Bearing, Ball	1
10	8.759-027.0	Manifold	1	29	8.754-828.0	Shaft, 1" Hollow 3035G1	1
11	8.717-233.0	O-ring Ø1.78 X 15.6	6		8.754-832.0	Shaft, 1" Hollow 3535G1	1
12	See Kits Below	Valve Assembly	6		8.754-833.0	Shaft, 1" Hollow 4035G1	1
13	9.803-948.0	O-ring Ø1.78 X 18.77	6	30	8.754-219.0	Oil Dipstick	1
14	9.803-949.0	Valve Plug	6	31	8.754-840.0	Bearing Needle	1
15	8.754-850.0	Lock washer	2	32	8.754-826.0	Seal, Crankshaft	1
16	8.758-217.0	Bolt, manifold M14x60	2	33	9.802-889.0	Washer	4
17	9.803-198.0	Washer, Copper G3/8	1	34	9.803-243.0	Screw	4
18	8.707-262.0	Plug, Brass G3/8	2	35	9.803-215.0	Washer 6 mm	4
19	See Kits Below	Valve Seat	6	36	9.803-244.0	Screw	4

HPP3035G1 SERIES PUMP EXPLODED VIEW PARTS LIST

ITEM	PART NO.	DESCRIPTION	QTY
37	9.803-217.0	Washer	4
38	9.803-217.0	Washer	4
39	8.752-824.0	Screw, M6 x 20	4
40	9.803-218.0	Washer, 6 mm	10
41	8.754-864.0	Flange, Engine	1
42	8.754-855.0	Bolt, Plunger	3
43	8.754-092.0	Spacer, Copper	3
44	8.754-849.0	Plunger, 14 mm	3
45	9.803-962.0	Spacer, Copper	3
46	8.759-032.0	Plunger Rod	3
47	9.803-965.0	Connecting Rod Pin	3
48	9.803-966.0	Connecting Rod	3
49	8.933-020.0	Screw, Connecting Rod	6
50	8.754-847.0	O-ring Ø2.62 X 111.62	1
51	8.754-842.0	Cover, Crankcase	1
52	9.803-906.0	O-ring Ø1.78 X 14	1
53	9.803-202.0	Sight Glass, G3/4	1

* Available in kit (See below)

REPAIR KIT NUMBER	8.759-031.0	8.754-861.0	8.754-862.0	8.754-859.0	9.803-937.0
KIT DESCRIPTION	Plunger Seal 14mm	Seal Packing 14mm	Plunger 14mm	Complete Valve	Plunger Oil Seals
ITEM NUMBERS INCLUDED	4, 5, 7, 16	4, 5, 6, 7, 16	43, 44, 45, 46	12, 13, 14,	2
NUMBER OF CYLINDERS KIT WILL SERVICE	3	3	1	6	3

VBA UNLOADER EXPLODED VIEW

6.6 GPM @3500 PSI 9.803-899.0
 6.6 GPM @4000 PSI 9.803-900.0

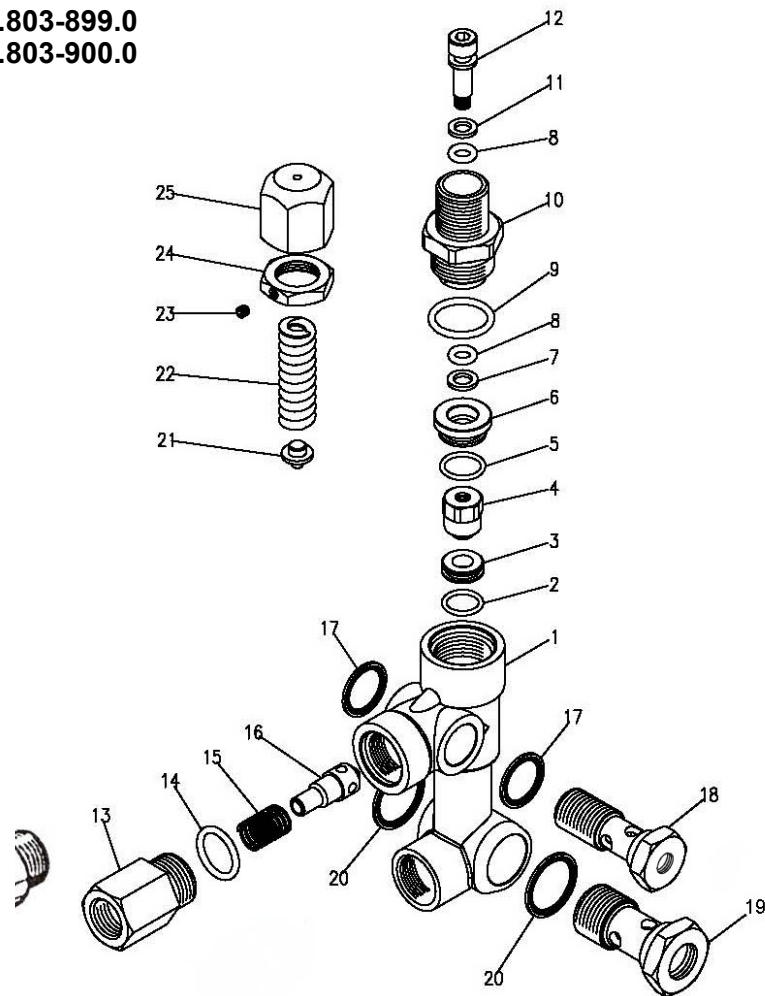

VBA UNLOADER EXPLODED VIEW PARTS LIST

ITEM	PART NO.	DESCRIPTION	KIT	QTY	ITEM	PART NO.	DESCRIPTION	KIT	QTY
1		Body Valve (KG)		1	17	9.802-893.0	Seal Washer 3/8		2
		Body Valve (KS)		1	18	9.803-915.0	Banjo Bolt 3/8" w 1/8" Pilot		1
2		O-Ring A,C		1		9.803-919.0	Banjo Bolt 3/8" Solid Cap		1
3		Seat C		1	19	9.803-920.0	Banjo Bolt 1/2" w 1/4" Pilot		1
4		Ball, Sub-assy	C	1		8.750-105.0	Banjo Bolt 1/2" Solid Cap		1
5		O-Ring	A	1		9.803-919.0	Banjo Bolt 3/8" Solid Cap		1
6	9.803-907.0	Guide Bushing		1	20	9.803-921.0	Seal Washer 1/2		2
7		Teflon Ring		1	21		Plate	C	1
8		O-Ring	A	1	22		Spring	C	1
9		O-Ring	A	2	23	8.933-021.0	Set Screw		1
10	9.803-911.0	Connector		1	24	9.803-925.0	Nut		1
11		Teflon Ring	A	1	25	9.803-926.0	Brass Handle		1
12	70-120207	Stem C		1	Kit A	8.717-672.0	O-Ring Repair Kit		
13	9.803-914.0	Connector Female		1	Kit B	8.717-673.0	Outlet Kit		
14		O-Ring	A,B	1	Kit C	8.717-674.0	Stem Repair Kit		
15		Spring	B	1					
16		Poppet	B	1					

VBT UNLOADER EXPLODED VIEW

8.754-696.0
UNLOADER, VBT BANJO 1/2M 3/8M, 3000PSI (SPARE)

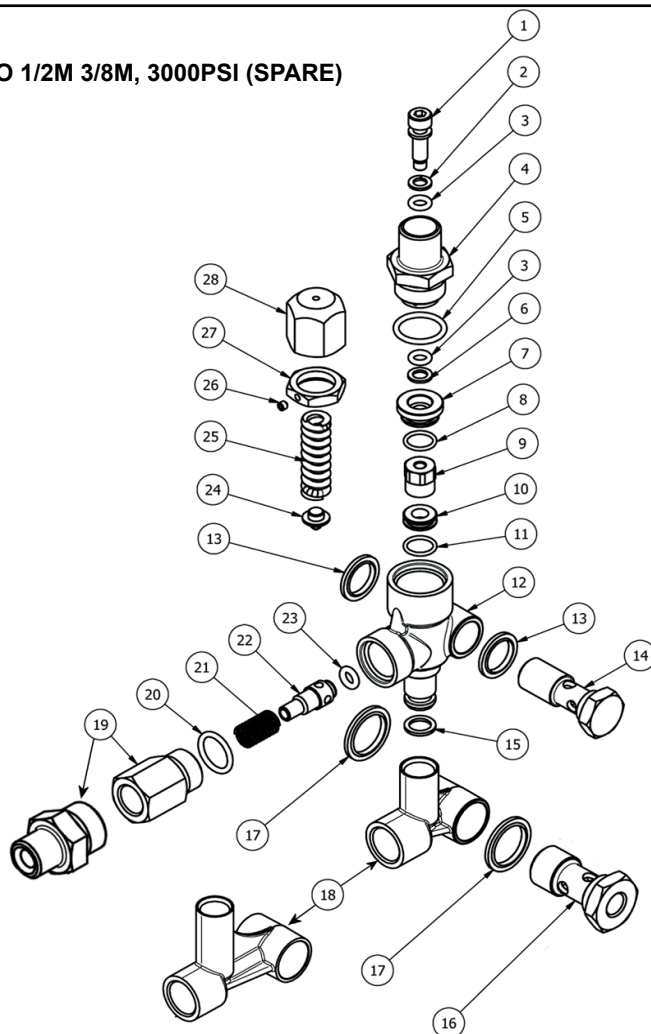

VBT UNLOADER EXPLODED VIEW PARTS LIST

ITEM	PART #	DESCRIPTION	KIT	QTY	ITEM	PART #	DESCRIPTION	KIT	QTY
1*	8.754-929.0	Stem	C	1	17	9.803-914.0	Seal Washer 1/2)		1
2*	9.803-912.0	Backup Ring	A	1	18	8.754-937.0	Bypass Manifold		1
3*	8.754-930.0	O-ring, Ø2.62 x 6.02	A	2	19	9.802-892.0	Outlet Connector 3/8 MPT		1
4	8.730-882.0	Stem Connector		1	20*	9.803-191.0	O-ring, Ø2.62 X 17.13	A,B	1
5*	9.803-193.0	O-ring, Ø2.62 x 20.24	A	1	21*	8.933-017.0	Poppet Spring	B	1
6*	9.803-908.0	Backup Ring	A	1	22*	8.754-939.0	Poppet	B	1
7	9.803-907.0	Guide Bushing		1	23*	8.754-940.0	O-ring, Ø3 x 6	A,B	1
8*	9.803-906.0	O-ring, Ø1.78 x 14	A	1	24*	8.754-961.0	Plate	C	1
9*	8.754-959.0	Ball SubAssembly	C	1	25*	8.933-018.0	Spring 1500-4000 PSI	C	1
10*	8.754-933.0	Seat	C	1	26	8.933-021.0	Set Screw		1
11*	8.754-934.0	O-ring, Ø1.78 x 12.42	A,C	1	27	9.803-925.0	Nut		1
12	8.754-935.0	Valve Body		1	28	9.803-926.0	Knob, Brass, Unloader		1
13	9.802-893.0	Seal Washer 3/8		1					
14	9.803-919.0	Banjo Bolt 3/8		1					
15*	8.754-936.0	O-ring, Ø2.62 x 10.78	A	1					
16	9.803-920.0	Banjo Bolt, 1/2, w/1/4" Port		1					

* Included in Kit

Kit A 8.754-941.0 O-Ring Repair Kit
Kit B 8.754-942.0 Outlet Repair Kit
Kit C 8.754-957.0 Stem Repair Kit

WIRING DIAGRAM - 965SS, 1065SS

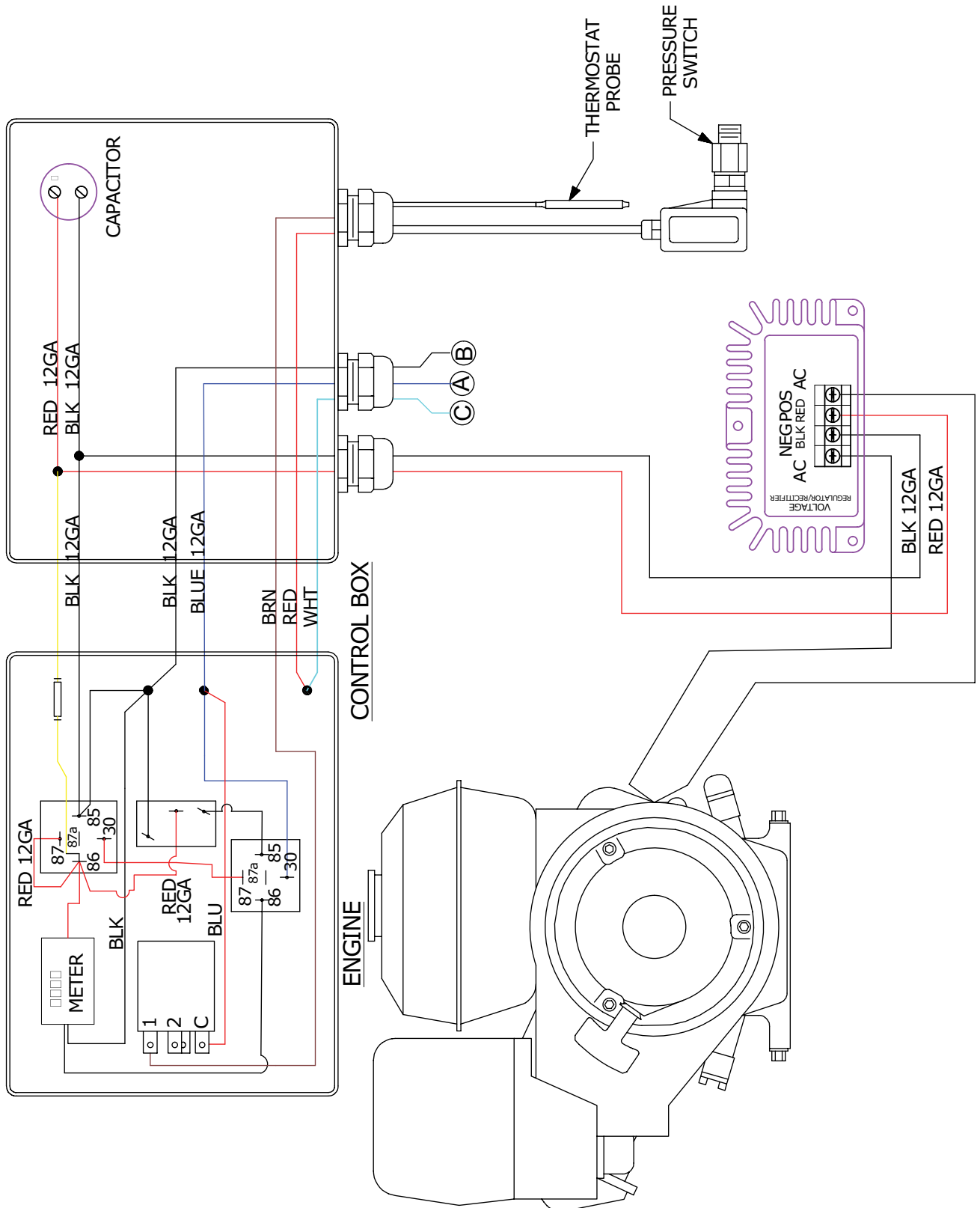

WIRING DIAGRAM - 965SS CAL, 1065SSE CAL, 1075SSE CAL, 1075BE CAL

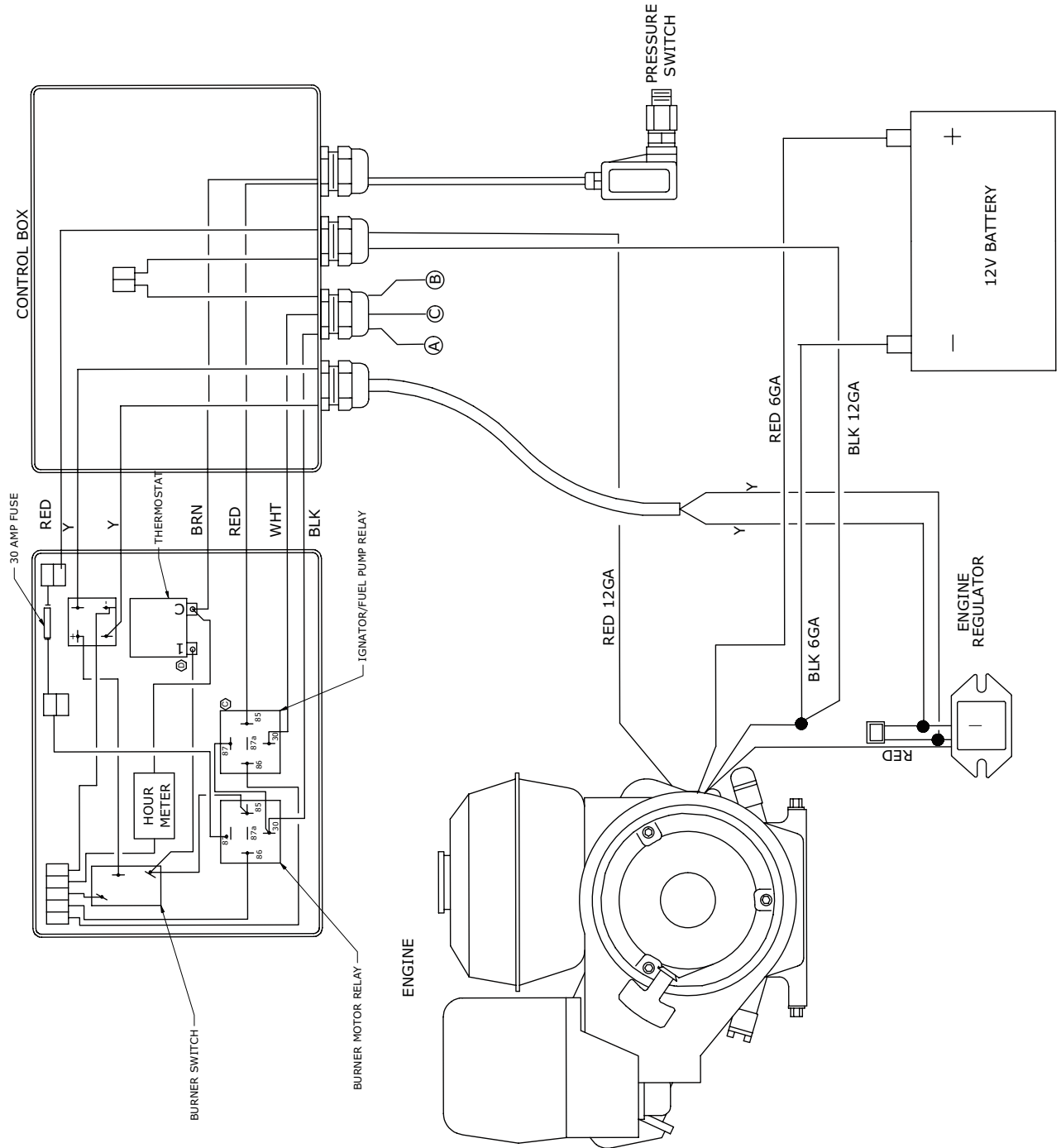

WIRING DIAGRAM - 1075BE COMPACT

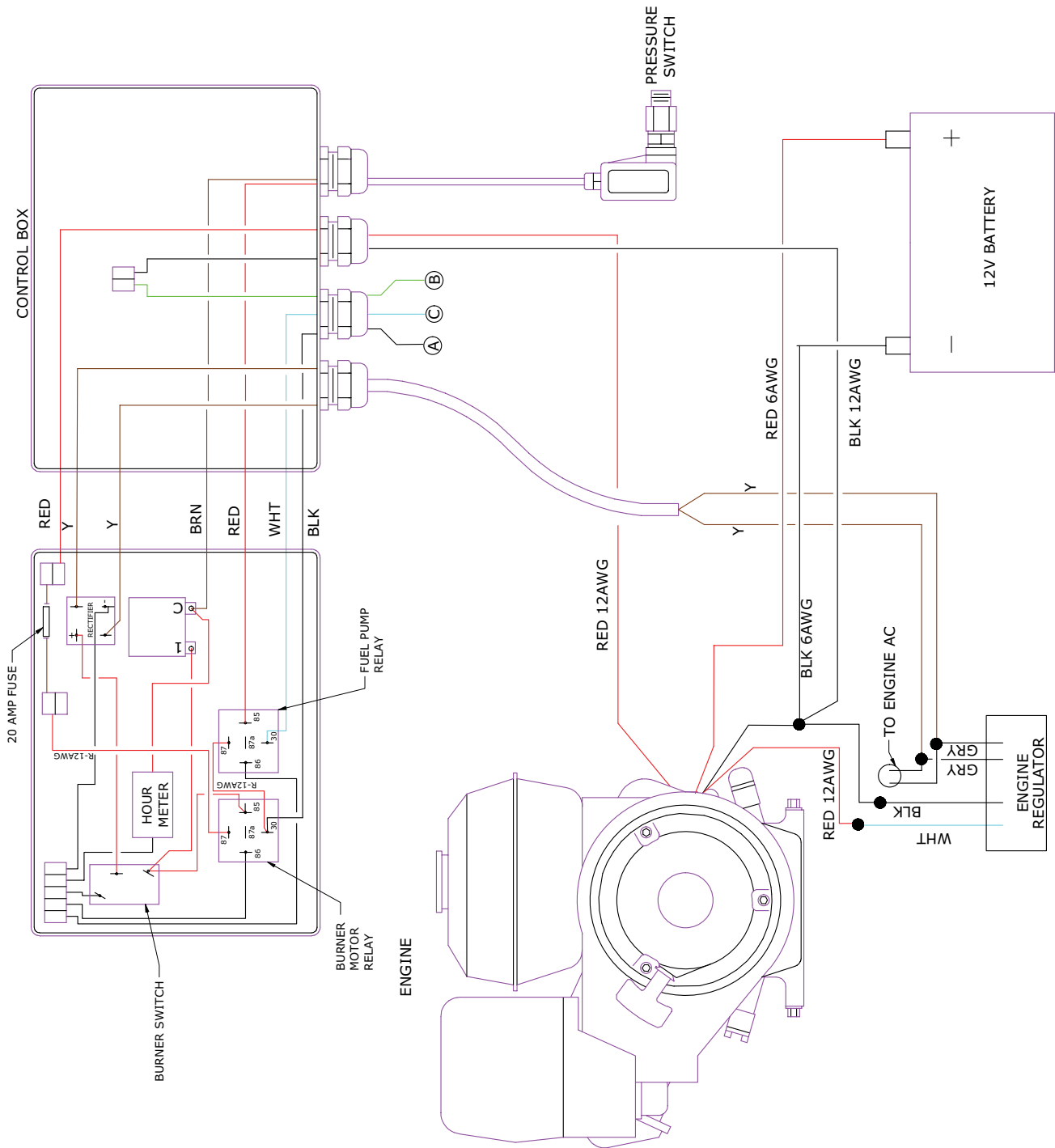

WIRING DIAGRAM - BURNER ALL MODELS

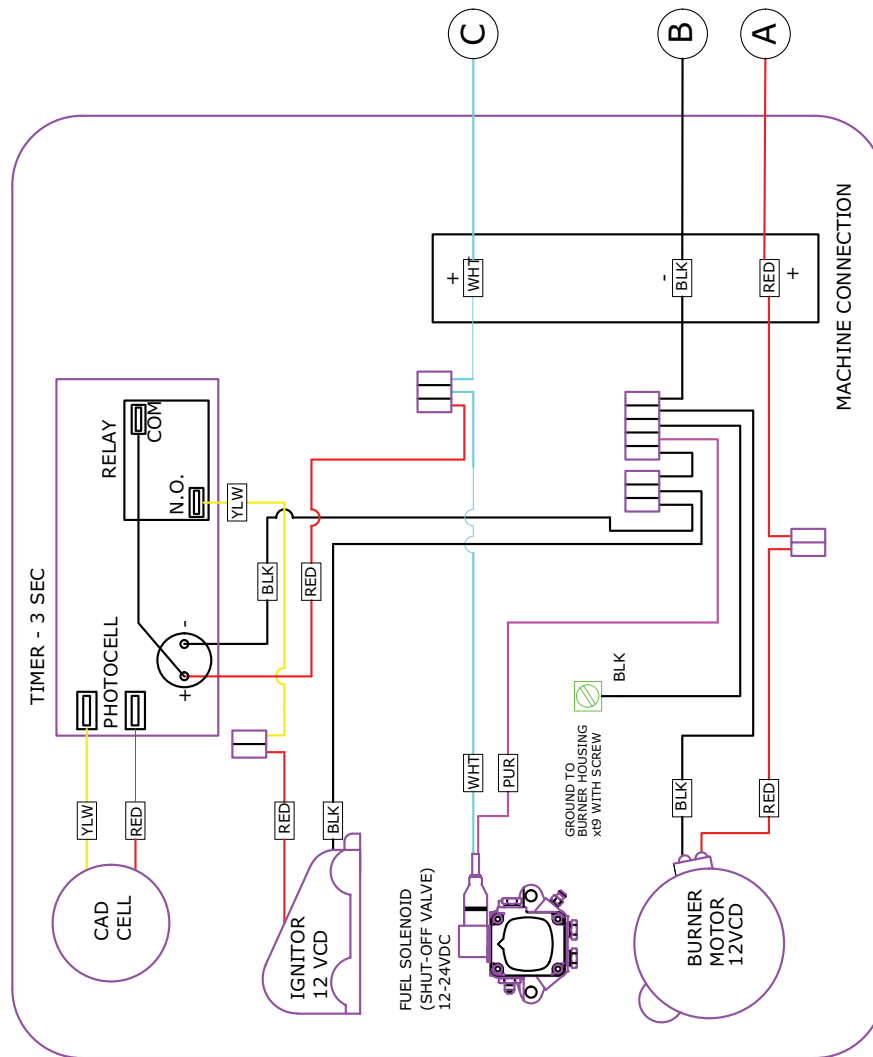

1. APPLY 12V:
 -BURNER MOTOR, STARTS FUEL FLOW
 -FUEL SOLENOID, FUEL NOZZLE START TO ATOMIZE DIESEL
 -TIMER DELAY, ACTIVATES THE IGNITOR
2. AFTER 3 SEC, TIMER RELAY SHUTS OFF THE IGNITOR (CAD CELL WILL START THE IGNITOR AGAIN IF FLAME IS LOST)
3. REMOVE 12V
 -BURNER MOTOR, STOPS FUEL FLOW
 -FUEL SOLENOID, BYPASS THE FUEL
 -TIMER DELAY, SHUTS OFF THE IGNITOR
4. SEQUENCE STARTS AGAIN WHEN 12V APPLIED

If you need service on your pressure washer, contact your local Hotsy dealer or visit www.Hotsy.com. Smart phone users scan the code below to link directly to the Service Request page.



To REGISTER your pressure washer, please visit our Warranty Registration page at www.hotsy.com/WarrantyRegistration.aspx or scan the code below with your smart phone.

