

# Landa MHC

Hot Water - Gasoline Powered - Diesel/Oil Heated

# LANDA®

## Operator's Manual

### Pressure Washer



<b>MODELS:</b>	<b>MHC4-30324</b> <b>1.110-039.0</b>
	<b>MHC4-35324E</b> <b>1.110-042.0</b>
	<b>MHC3-30324</b> <b>1.110-038.0</b>
	<b>MHC4-30324E/S</b> <b>1.110-041.0</b>
	<b>MHC4-30324E</b> <b>1.110-040.0</b>
	<b>MHC4-35324E/B</b> <b>1.110-077.0</b>

For the Landa Dealer nearest you, consult our web page at [www.landa.com](http://www.landa.com)



Intertek



9.800-950.0 - BA 03/04/21

**Machine Data Label**

---

Model: \_\_\_\_\_

Date of Purchase: \_\_\_\_\_

Serial Number: \_\_\_\_\_

Dealer: \_\_\_\_\_

Address: \_\_\_\_\_

Phone Number: \_\_\_\_\_

Sales Representative: \_\_\_\_\_

<b>Machine Data Label</b> . . . . .	<b>2</b>	VBA 35 Unloader Valve . . . . .	48
<b>Table of Contents</b> . . . . .	<b>3</b>	VRT3 Unloader . . . . .	50
<b>How To Use This Manual</b> . . . . .	<b>4</b>	Wayne Burner . . . . .	52

**Safety**

Introduction & Safety Information . . . . .	5
Important Safety Information . . . . .	5

**Operations**

Component Identification . . . . .	9
Assembly Instructions . . . . .	10
Operation Instructions . . . . .	11
Detergents And General Operating Techniques . . . . .	12
Thermal Pump Protection . . . . .	12
Shutdown Instructions . . . . .	13

**Maintenance**

Storage . . . . .	14
After Extended Storage . . . . .	14
Engine Maintenance . . . . .	14
Maintenance And Service . . . . .	15
Unloader Valves . . . . .	15
Winterizing Procedure . . . . .	15
High Limit Hot Water Thermostat . . . . .	15
Pumps . . . . .	15
Cleaning of Coils . . . . .	15
Rupture Disk . . . . .	15
Fuel . . . . .	15
Burner Nozzle . . . . .	16
Landa MHC Oil Burner . . . . .	16
Landa MHC Burner Air Adjustment . . . . .	16
Removal of Soot and Heating Coil . . . . .	17
Coil Re-installation . . . . .	17
Troubleshooting . . . . .	18
Preventative Maintenance . . . . .	21

**Parts**

Landa MHC . . . . .	24
Landa MHC4-35324E/B . . . . .	25
Landa MHC Coil . . . . .	26
Control Panel . . . . .	32
Downstream Injector . . . . .	33
Hose & Spray Gun . . . . .	34
Unloader - 4-35324E/B . . . . .	35
Pump - 8.915-321.0 . . . . .	36
Pump - 8.918-611.0 . . . . .	37
Pump - 8.928-783.0 . . . . .	38
LPP Series Pump . . . . .	40
LS.3 Series Pump . . . . .	42
LM.3 Series Pump . . . . .	44
VBT Unloader Valve . . . . .	46

## How To Use This Manual

This manual contains the following sections:

- How to Use This Manual
- Safety
- Operations
- Maintenance
- Parts List

The HOW TO USE THIS MANUAL section will tell you how to find important information for ordering correct repair parts.

Parts may be ordered from authorized dealers. When placing an order for parts, the machine model and machine serial number are important. Refer to the MACHINE DATA box which is filled out during the installation of your machine. The MACHINE DATA box is located on the inside of the front cover of this manual.

Model: _____
Date of Purchase: _____
Serial Number: _____
Dealer: _____
Address: _____
Phone Number: _____
Sales Representative: _____

The model and serial number of your machine is located on the back of the machine.

The SAFETY section contains important information regarding hazardous or unsafe practices of the machine. Levels of hazards are identified that could result in product damage, personal injury, or severe injury resulting in death.

The OPERATIONS section is to familiarize the operator with the operation and function of the machine.

The MAINTENANCE section contains preventive maintenance to keep the machine and its components in good working condition. They are listed in this general order:

- Storage
- Engine Maintenance
- Maintenance And Service
- Unloader Valves
- Winterizing Procedure
- High Limit Hot Water Thermostat
- Pump
- Cleaning of Coils
- Rupture Disk
- Fuel
- Burner Nozzle
- Landa MHC Oil Burner
- Landa MHC Burner Air Adjustment
- Fuel Pressure Adjustment
- Removal of Soot and Heating Coil
- Coil Reinstallation
- Troubleshooting
- Preventative Maintenance

The PARTS LIST section contains assembled parts illustrations and corresponding parts list. The parts lists include a number of columns of information:

- **REF** – column refers to the reference number on the parts illustration.
- **PART NO.** – column lists the part number for the part.
- **QTY** – column lists the quantity of the part used in that area of the machine.
- **DESCRIPTION** – column is a brief description of the part.
- **NOTES** – column for information not noted by the other columns.

*NOTE: If a service or option kit is installed on your machine, be sure to keep the KIT INSTRUCTIONS which came with the kit. It contains replacement parts numbers needed for ordering future parts.*

*NOTE: The manual part number is located on the lower right corner of the front cover.*

## Introduction & Safety Information

Thank you for purchasing this Pressure Washer.

We reserve the right to make changes at any time without incurring any obligation.

### Owner/User Responsibility:

The owner and/or user must have an understanding of the manufacturer's operating instructions and warnings before using this pressure washer. Warning information should be emphasized and understood. If the operator is not fluent in English, the manufacturer's instructions and warnings shall be read to and discussed with the operator in the operator's native language by the purchaser/owner, making sure that the operator comprehends its contents.

Owner and/or user must study and maintain for future reference the manufacturers' instructions.

The operator must know how to stop the machine quickly and understand the operation of all controls. Never permit anyone to operate the engine without proper instructions.

### SAVE THESE INSTRUCTIONS

This manual should be considered a permanent part of the machine and should remain with it if machine is resold.

**When ordering parts, please specify model and serial number. Use only identical replacement parts.**

**This machine is to be used only by trained operators.**

## Important Safety Information

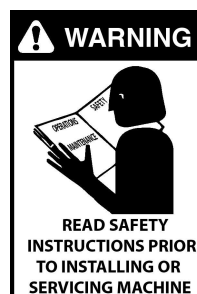

**WARNING:** To reduce the risk of injury, read operating instructions carefully before using.

**Pour réduire le risque de blessures, lire attentivement les instructions de fonctionnement avant l'utilisation.**

1. Read the owner's manual thoroughly. Failure to follow instructions could cause malfunction of the machine and result in death, serious bodily injury and/or property damage.
2. Know how to stop the machine and bleed pressure quickly. Be thoroughly familiar with the controls.
3. Stay alert — watch what you are doing.



**DANGER:** Keep wand, hose, and water spray away from electric wiring or fatal electric shock may result.

**DANGER:** Garder la lance, le boyau et le jet d'eau à l'écart de tout câblage électrique ou des chocs électriques mortels pourraient survenir.

4. All installations must comply with local codes. Contact your electrician, plumber, utility company or the selling dealer for specific details

## Safety.



**WARNING:** This machine exceeds 85 db appropriate ear protection must be worn.

**AVERTISSEMENT:** Cette machine excède 85 dB et une protection de l'ouïe appropriée doit être portée.



**WARNING:** High pressure spray can cause paint chips or other particles to become airborne and fly at high speeds. To avoid personal injury, eye, face, hand and foot safety devices must be worn.

**AVERTISSEMENT:** Un jet haute pression peut écailler la peinture

ou provoquer l'émission d'autres particules dans l'air et leur projection à hautes vitesses. Pour éviter les lésions corporelles, une protection des yeux, du visage, des mains et des pieds doit être portée lors de l'utilisation de cet équipement.

5. Always wear properly rated eye protection such as safety goggles or face shield while spraying. (Safety glasses do not provide full protection.)
6. Keep operating area clear of all persons.

**WARNING:** Flammable liquids can create fumes which can ignite, causing property damage or severe injury.

**AVERTISSEMENT:** Des liquides inflammables peuvent produire des vapeurs qui peuvent s'enflammer, causant ainsi des dommages à la propriété ou des blessures graves.



**WARNING:** Risk of explosion — Operate only where open flame or torch is permitted.

**AVERTISSEMENT:** Risque d'explosion-Utiliser uniquement dans des endroits où l'utilisation d'une flamme nue ou d'une torche est permise.



**WARNING:** Risk of fire — Do not add fuel when the product is operating or still hot.

**AVERTISSEMENT:** Risque d'incendie-Ne pas ajouter de carburant pendant que la machine fonctionne ou est encore chaude

**WARNING:** Do not use gasoline crankcase drainings or oil containing gasoline, solvents or alcohol. Doing so will result in fire and/or explosion.

**AVERTISSEMENT:** Ne pas utiliser d'essence, de drainage du carter de moteur ou d'essence contenant de l'huile, de solvants ou de l'alcool.



**WARNING:** Risk of fire — Do not Spray flammable liquids.

**AVERTISSEMENT:** Risque d'incendie-Ne pas pulvériser de liquides inflammables.

7. Allow engine to cool for 2 minutes before refueling. If any fuel is spilled, make sure the area is dry before testing the

spark plug or starting the engine. (Fire and/or explosion may occur if this is not done.)

Gasoline engines on mobile or portable equipment shall be refueled:

- a. outdoors;
- b. with the engine on the equipment stopped;
- c. with no source of ignition within 10 feet of the dispensing point; and
- d. with an allowance made for expansion of the fuel should the equipment be exposed to a higher ambient temperature.

In an overfilling situation, additional precautions are necessary to ensure that the situation is handled in a safe manner.

**WARNING:** Risk of injury. Disconnect battery ground terminal before servicing.

**AVERTISSEMENT:** Risque de blessures. Débrancher la borne de mise à la terre de la batterie avant de procéder à des opérations d'entretien.

8. When in use, do not place machine near flammable objects as the engine is hot.
9. Oil burning appliances shall be installed only in locations where combustible dusts and flammable gases or vapors are not present. Do not store or use gasoline near this machine.

- Use No. 1 or No. 2 heating oil (ASTM D306) only. **NEVER** use gasoline in your fuel oil tank. Gasoline is more combustible than fuel oil and could result in a serious explosion. **NEVER** use crankcase or waste oil in your burner. Fuel unit malfunction could result from contamination.
- Do not confuse gasoline and fuel oil tanks. Keep proper fuel in proper tank.



**WARNING: Risk of injury. Hot surfaces can cause burns. Use only designated gripping areas of spray gun and wand. Do not place hands or feet on non-insulated areas of the pressure washer.**

**AVERTISSEMENT: Risque de blessures. Les surfaces chaudes peuvent causer des brûlures. Utiliser uniquement les zones de**

**prise désignées du pistolet pulvérisateur et de la lance. Ne pas placer les mains ou les pieds sur des endroits non isolés de la laveuse à pression.**

- Transport/Repair with fuel tank EMPTY or with fuel shut-off valve OFF.



**WARNING: Hot discharge fluid. Do not touch or direct discharge stream at persons or animals or severe injury or death will result.**

**AVERTISSEMENT: Liquide de décharge chaud. Ne pas toucher ou décharger directement le jet vers des personnes ou des animaux, car cela risquerait de**

**causer des blessures graves ou même la mort.**

**WARNING: This machine produces hot water and must have insulated components attached to protect the operator.**

**AVERTISSEMENT: Cette machine produit de l'eau chaude et doit comporter des composants isolés attachés pour protéger l'opérateur**

- To reduce the risk of injury, close supervision is necessary when a machine is used near children. Do not allow children to operate the pressure washer. **This machine must be attended during operation.**



**WARNING: Grip cleaning wand securely with both hands before starting. Failure to do this could result in injury from a whipping wand.**

**AVERTISSEMENT: Agripper la lance de nettoyage avec les deux mains avant de commencer. Le non-respect de cette consigne pourrait mener à des blessures**

**causées par le mouvement violent de la lance.**

- Never make adjustments on machine while in operation.
- Be certain all quick coupler fittings are secured before using pressure washer.



**WARNING: High pressure developed by these machines will cause personal injury or equipment damage. Keep clear of nozzle. Use caution when operating. Do not direct discharge stream at people or animals, or severe injury or death will result.**

**AVERTISSEMENT: La haute pression générée par ces machines causera des lésions corporelles ou des dommages à l'équipement. Se tenir à l'écart de la buse. Faire preuve de prudence lors de l'utilisation. Ne pas décharger directement le jet vers des personnes ou des animaux, car cela risquerait de causer des blessures graves ou même la mort.**



**WARNING: Protect machine from freezing.**

**AVERTISSEMENT: Protéger la machine contre le gel.**

- To keep machine in best operating conditions, it is important you protect machine from freezing. Failure to protect machine from freezing could cause malfunction of the machine and result in death, serious bodily injury, and/or property damage. Follow storage instructions specified in this manual.
- Inlet water must be clean fresh water and no hotter than 90°F.



**DANGER: Risk of asphyxiation.**  
*Use this product only in a well ventilated area.*

**DANGER: Risque d'asphyxie.**  
*Utiliser ce produit uniquement dans un endroit bien ventilé.*

18. Avoid installing machines in small areas or near exhaust fans. Adequate oxygen is needed for combustion or dangerous carbon monoxide will result.
19. Manufacturer will not be liable for any changes made to our standard machines or any components not purchased from us.
20. The best insurance against an accident is precaution and knowledge of the machine.



**WARNING: Be extremely careful when using a ladder, scaffolding or any other relatively unstable location. The cleaning area should have adequate slopes and drainage to reduce the possibility of a fall due to slippery surfaces.**

**AVERTISSEMENT: Faire preuve d'une extrême prudence au moment d'utiliser une échelle, des**

**échafaudages ou toute autre surface relativement instable. La zone de nettoyage doit avoir une pente et un drainage adéquats pour réduire la possibilité d'une chute due à une surface glissante.**

21. Do not allow acids, caustic or abrasive fluids to pass through the pump.
22. Never run pump dry or leave spray gun closed longer than 1-2 minutes.
23. Machines with shut-off spray gun should not be operated with the spray gun in the off position for extensive periods of time as this may cause damage to the pump.
24. Protect discharge hose from vehicle traffic and sharp objects. Inspect condition of high pressure hose before using or bodily injury may result.
25. Before disconnecting discharge hose from water outlet, turn burner off and open spray gun to allow water to cool below 100° before stopping the machine. Then open the spray gun to relieve pressure. Failure to properly cool down or maintain the heating coil may result in a steam explosion.

26. Do not overreach or stand on unstable support. Keep good footing and balance at all times.
27. Do not operate this machine when fatigued or under the influence of alcohol, prescription medications, or drugs.
28. Use only kerosene, No. 1 home heating fuel, or diesel in burner fuel tank. If diesel is used, add a soot remover to every tankful.



**Follow the maintenance instructions specified in the manual.**



**Component Identification**

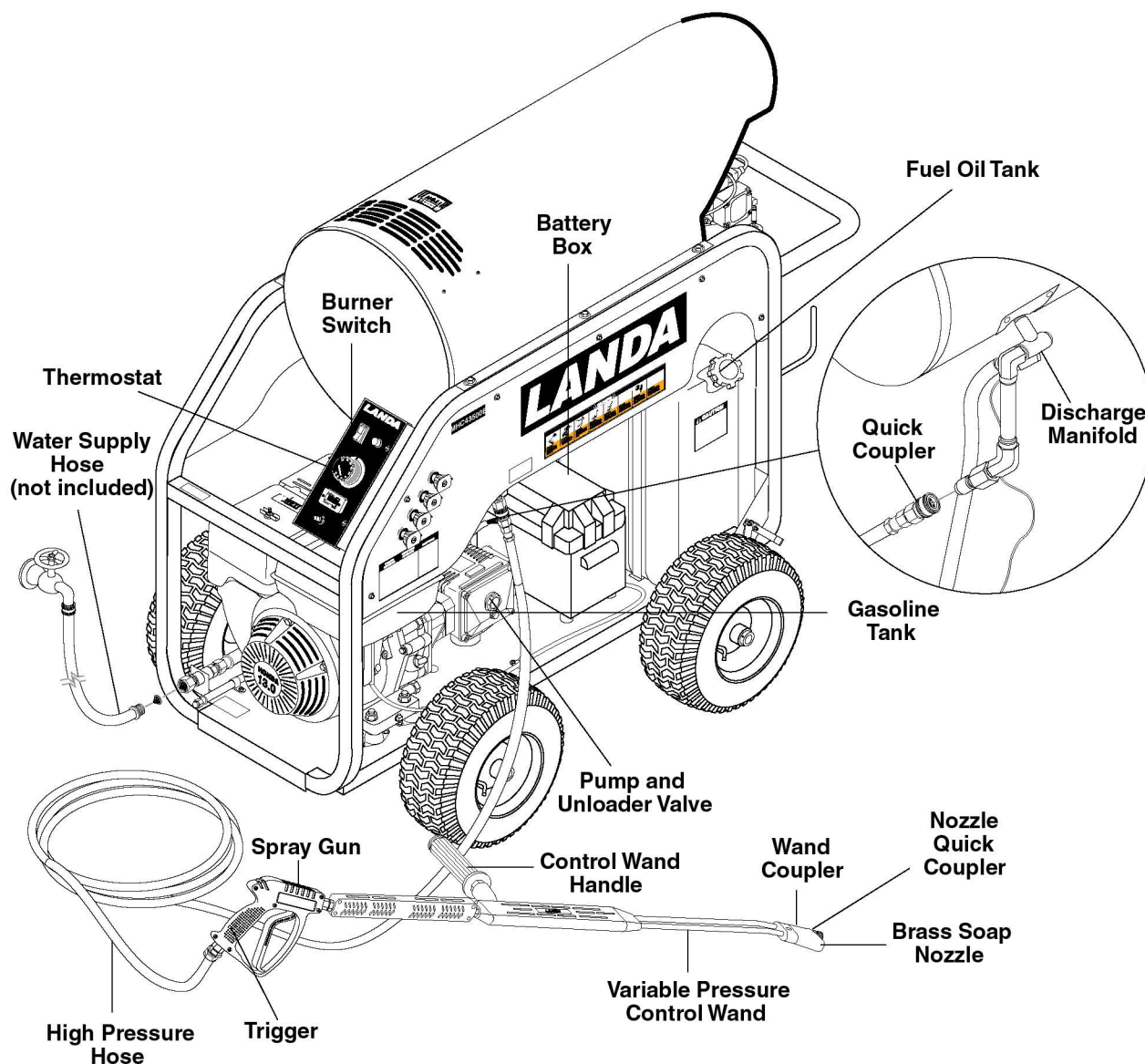

**Pump** — Delivers a specific gpm to the high pressure nozzle which develops pressure.

**Spray Gun** — Controls the application of water and detergent onto cleaning surface with trigger device. Includes safety latch.

**Detergent Injector** — Allows you to siphon and mix detergents.

**Wand** — Must be connected to the spray gun.

**High Pressure Hose** — Connect one end to water pump high pressure discharge nipple and the other end to spray gun.

**Rupture Disk** — Secondary pressure release in the unlikely event the unloader valve fails.

**Unloader Valve** — Safety device which, when the spray gun closes, prevents over pressurization (not shown).

**NOTE:** If trigger on spray gun is released for more than 2 minutes, water will leak from the pump protector. Warm water will discharge from pump protector onto floor. This system prevents internal pump damage.

# Operations

## Assembly Instructions

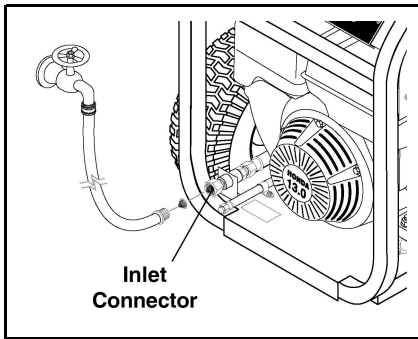

**STEP 1:** Attach a 5/8" garden hose to inlet connector. Minimum flow should be 5 gpm.

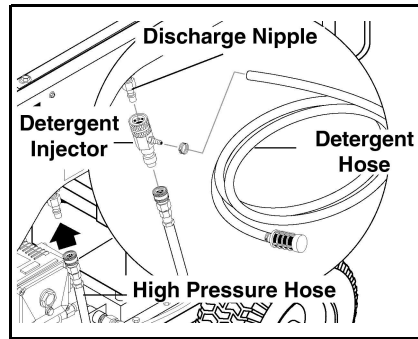

**STEP 2:** Attach high pressure hose to discharge nipple using quick coupler. Lock coupler securely into place by pulling back coupler collar and inserting it onto discharge nipple, then pushing collar forward to lock in place.

**NOTE:** If using detergent injector, attach detergent injector to discharge nipple using quick coupler. Attach high pressure hose to other end of detergent injector.

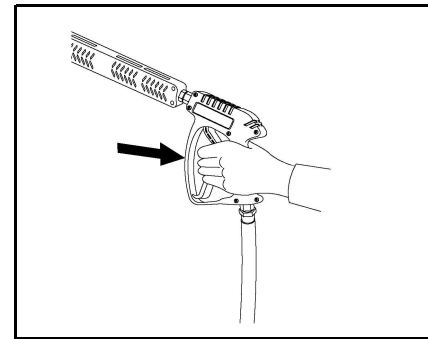

**STEP 3:** Attach wand to spray gun using teflon tape on threads to prevent leakage. Attach swivel connector on discharge hose to spray gun using teflon tape on threads. Attach swivel connector on high pressure hose to spray gun using teflon tape on threads. Engage safety latch to prevent from triggering gun.

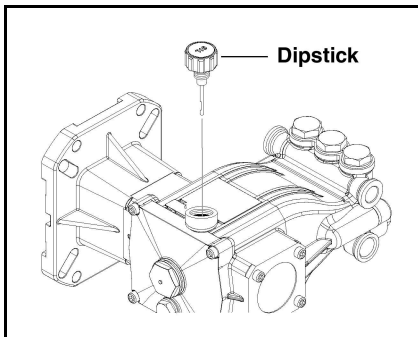

**STEP 4:** Check oil level on sight glass on side of pump. Oil should be visible one-half way up sight glass (SAE 10W-40 non-foaming). The oil level can also be checked by using the dipstick on the top of the pump.

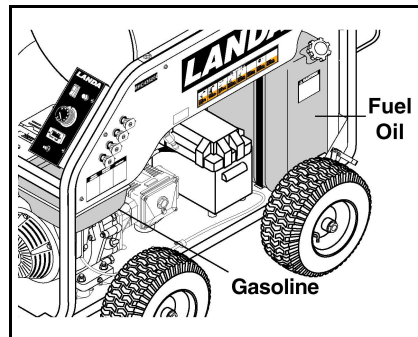

**STEP 5:** Fill gasoline tank and check engine oil. Fill fuel tank. Do not confuse gasoline and fuel oil (diesel) tanks. Keep proper fuel in proper tanks.

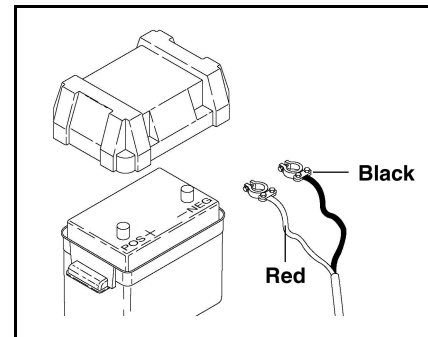

**STEP 6:** On electric start models only, you will need to install a battery making sure that the red cable is attached to the positive terminal. Use a Group U1 garden tractor style type of battery rated for 300 CCA (battery not included).

**CAUTION:** These machines are intended to be protected from outside environments.

**ATTENTION:** Ces machines sont conçues pour être protégées contre l'environnement extérieur.

**Operation Instructions**

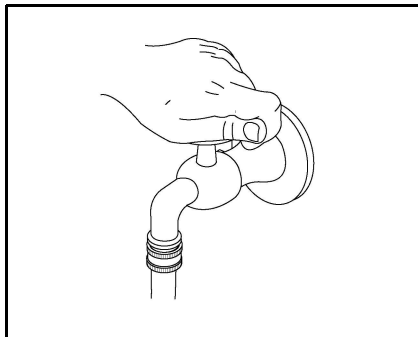

**STEP 1:** Turn on water at faucet and pull trigger on spray gun allowing water to flow until all air has discharged from system. Check for water leaks; tighten as needed.

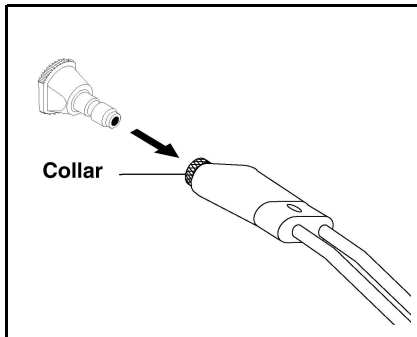

**STEP 2:** Before installing nozzle, turn on water supply and run machine allowing water to flush through the system until clear. Pull wand coupler collar back and insert desired pressure nozzle into coupler then secure by pushing coupler collar forward.

**NOTE:** Variable pressure control wand handle must be turned clockwise to enable water to flow out of the high pressure nozzle.

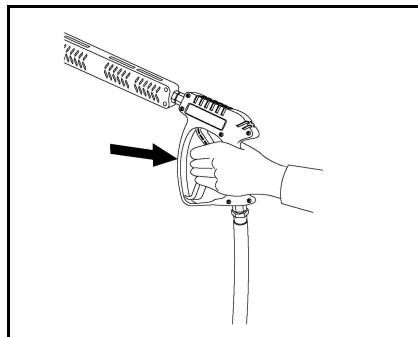

**STEP 4:** With spray nozzle pointed away from you or anyone else, press trigger on spray gun to obtain pressurized cold water spray.

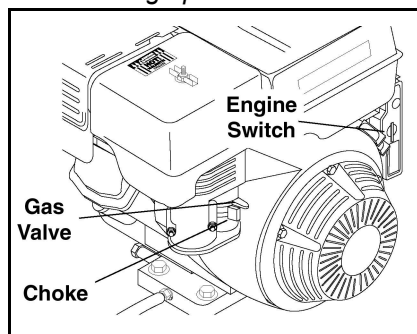

**STEP 3:** Read engine manual, turn on gas valve and choke. Turn the engine switch to the START position and hold it there until the engine starts.

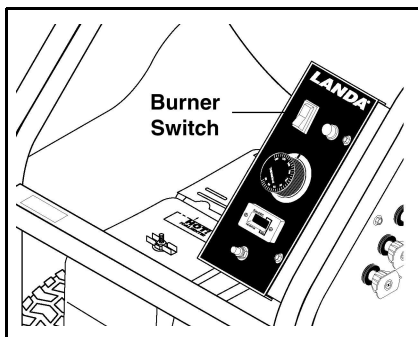

**STEP 5:** For hot water, turn burner switch ON when a steady stream of water flows out of the spray gun. Burner will light automatically.

**NOTE:** Do not start machine with burner switch on.

**NOTE:** Do not use the electric starter for more than five seconds at a time. If the engine fails to start, release the switch and wait ten seconds before operating the starter again. When the engine starts, allow the engine switch to return to the ON position. If the engine is to be started without the battery, turn switch to start position and pull rope to start. Turn off choke.

**WARNING:** Starter cord kickback (rapid retraction) can result in bodily injury. Kickback will pull hand and arm toward engine faster than you can let go. ALWAYS relieve spray gun pressure before pulling starter cord. Pull starter cord slowly until resistance is felt, then pull rapidly.

**AVERTISSEMENT:** Le retour du cordon de lancement (rétraction rapide) peut causer des lésions corporelles. La rétraction rapide de la corde du démarreur (recul) attire la main et le bras vers le moteur plus vite qu'il n'est possible de lâcher la corde. Toujours retenir la charge solidement en place avant de conduire. Tirer lentement sur le cordon de lancement jusqu'à ce qu'une résistance soit sentie, puis tirer rapidement.

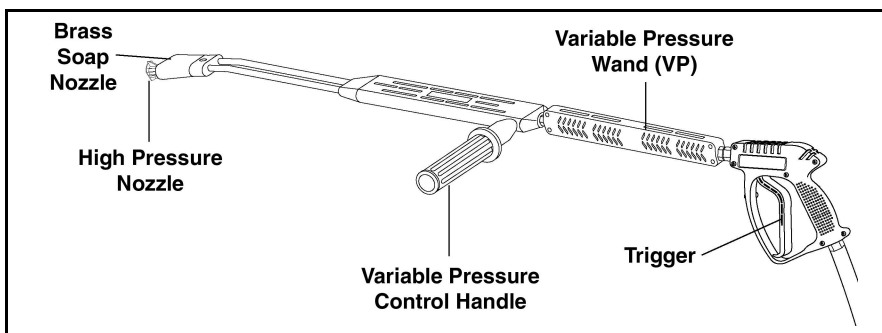

Selection of high or low pressure is accompanied by turning the handle. **NOTE:** High pressure nozzle must be inserted at end of wand to obtain high pressure. To apply soap read Detergents and General Operating Techniques section.

## Operations

### Detergents And General Operating Techniques



**WARNING:** Some detergents may be harmful if inhaled or ingested, causing severe nausea, fainting or poisoning. The harmful elements may cause property damage or severe injury.

**AVERTISSEMENT:** Certains détergents peuvent être dangereux s'ils sont inhalés ou ingérés, provoquant de fortes

nausées, des évanouissements et l'empoisonnement. Les éléments dangereux peuvent causer des dommages à la propriété ou des blessures graves.

**STEP 1:** Use detergent designed specifically for pressure washers. Household detergents could damage the pump. Prepare detergent solution as required by the manufacturer. Fill a container with pressure washer detergent. Place the filter end of detergent suction tube into the detergent container.

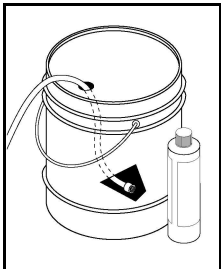

**STEP 2:** Apply safety latch to spray gun trigger. Secure black detergent nozzle into quick coupler. **NOTE:** Detergent cannot be applied using the Yellow nozzle.

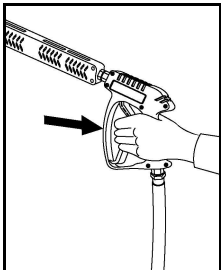

**STEP 3:** With the motor running, pull trigger to operate machine. Liquid detergent is drawn into the machine and mixed with water. Apply detergent to work area. Do not allow detergent to dry on surface.

**IMPORTANT:** You must flush the detergent injection system after each use by placing the suction tube into a bucket of clean water, then run the pressure washer in low pressure for 1-2 minutes.

### Thermal Pump Protection

If you run your pressure washer for 3-5 minutes without pressing the trigger on the spray gun, circulating water in the pump can reach high temperatures. When the water reaches this temperature, the pump protector engages and cools the pump by discharging the warm water onto the ground. This thermal device prevents internal damage to the pump.

### Cleaning Tips

Pre-rinse cleaning surface with fresh water. Place detergent suction tube directly into cleaning solution and apply to surface at low pressure (for best results, limit your

work area to sections approximately 6 feet square and always apply detergent from bottom to top). Allow detergent to remain on surface 1-3 minutes. Do not allow detergent to dry on surface. If surface appears to be drying, simply wet down surface with fresh water. If needed, use brush to remove stubborn dirt. Rinse at high pressure from top to bottom in an even sweeping motion keeping the spray nozzle approximately 1 foot from cleaning surface. Use overlapping strokes as you clean and rinse any surface. For best surface cleaning action spray at a slight angle.

### Recommendations:

- Before cleaning any surface, an inconspicuous area should be cleaned to test spray pattern and distance for maximum cleaning results.
- If painted surfaces are peeling or chipping, use extreme caution as pressure washer may remove the loose paint from the surface.
- Keep the spray nozzle a safe distance from the surface you plan to clean. High pressure wash a small area, then check the surface for damage. If no damage is found, continue to pressure washing.

### CAUTION - Never use:

- Bleach, chlorine products and other corrosive chemicals
- Liquids containing solvents (i.e., paint thinner, gasoline, oils)
- Tri-sodium phosphate products
- Ammonia products or acid-based products

**These chemicals will harm the machine and will damage the surface being cleaned.**

### ATTENTION: Ne jamais utiliser:

- Eau de Javel, produits à base de chlore et autres produits chimiques corrosifs
- Liquides contenant des solvants (c.-à-d. diluant à peinture, essence, huiles, etc.)
- Produits à base de triphosphate de sodium
- Ammoniac ou produits à base d'acide

**Ces produits chimiques endommageront la machine et endommageront la surface étant nettoyée.**

### Rinsing

It will take a few seconds for the detergent to clear. Apply safety latch to spray gun. Remove black soap nozzle from the quick coupler. Select and install the desired high pressure nozzle. **NOTE:** You can also stop detergent from flowing by simply removing detergent siphon tube from bottle.

**Shutdown Instructions**

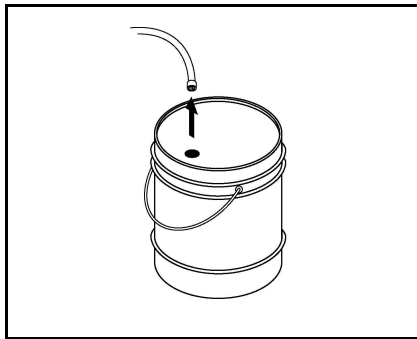

**STEP 1:** Remove detergent suction tube from container and insert into one (1) gallon of fresh water. Pull trigger on spray gun and siphon water for one minute.

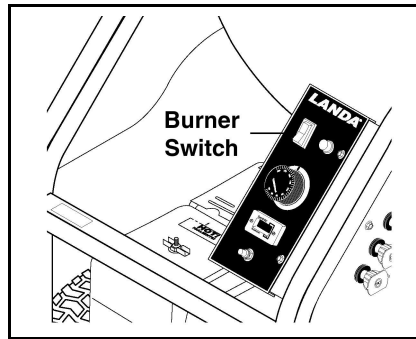

**STEP 2:** Turn burner switch off and continue spraying, allowing the water to cool below 100° F.

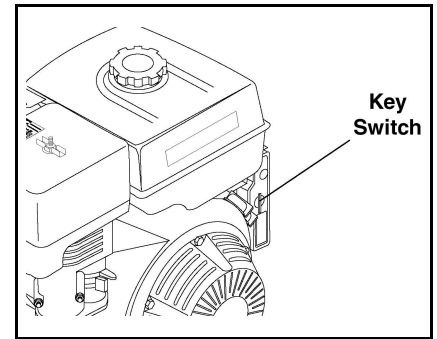

**STEP 3:** Turn engine off.

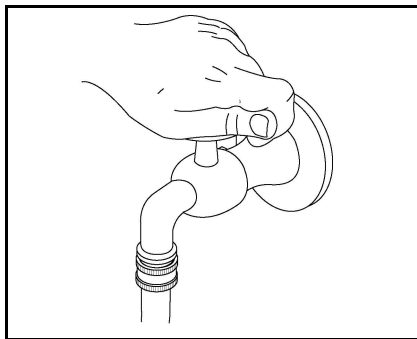

**STEP 4:** Turn off water supply.

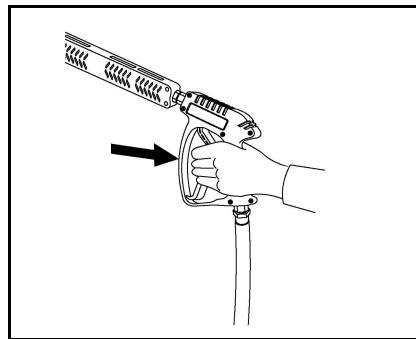

**STEP 5:** Open spray gun to relieve remaining pressure.

## Maintenance

### Storage

**CAUTION:** Always store your pressure washer in a location where the temperature will not fall below 32°F (0°C). The pump in this machine is susceptible to permanent damage if frozen. **FREEZE DAMAGE IS NOT COVERED BY WARRANTY.**

**ATTENTION:** Toujours entreposer la laveuse à pression dans un endroit où la température ne sera pas inférieure à 32°C (0 °F). La pompe sur cette machine est susceptible de subir des dommages si elle est exposée au gel. **LES DOMMAGES DUS AU GEL NE SONT PAS COUVERTS PAR LA GARANTIE**

1. Stop the pressure washer, squeeze spray gun trigger to release pressure.
2. Detach water supply hose and high pressure hose.
3. Turn on the machine for a few seconds, until remaining water exits. Turn engine off immediately.
4. Drain the gas and oil from the engine.
5. Do not allow high pressure hose to become kinked.
6. Store the machine and accessories in a room which does not reach freezing temperatures.

**CAUTION:** Failure to follow the above directions will result in damage to your pressure washer.

**ATTENTION:** Le non-respect des directives ci-dessus entraînera des dommages à la laveuse à pression

When the pressure washer is not being operated or is being stored for more than one month, follow these instructions:

1. Replenish engine oil to upper level.
2. Drain gasoline from fuel tank, fuel line, fuel valve and carburetor.
3. Pour about one teaspoon of engine oil through the spark plug hole, pull the starter grip several times and replace the plug. Then pull the starter grip slowly until you feel increased pressure which indicates the piston is on its compression stroke and leave it in that position. This closes both the intake and exhaust valves to prevent rusting of cylinder.
4. Cover the pressure washer and store in a clean, dry place that is well ventilated away from open flame or sparks. **NOTE:** The use of a fuel additive, such as STA-BIL<sup>®</sup>, or an equivalent, will minimize the formulation of fuel deposits during shortage. Such additives may be added to the gasoline in the

fuel tank of the engine, or to the gasoline in a storage container.

### After Extended Storage



**CAUTION:** Prior to restarting, thaw out any possible ice from pressure washer hoses, spray gun or wand.

**ATTENTION:** Avant de redémarrer, faire fondre la glace se trouvant sur les boyaux, le pistolet pulvérisateur ou la lance de la laveuse à pression.

### Engine Maintenance

During the winter months, rare atmospheric conditions may develop which will cause an icing condition in the carburetor. If this develops, the engine may run rough, lose power and may stall. This temporary condition can be overcome by deflecting some of the hot air from the engine over the carburetor area. **NOTE:** Refer to the engine manufacturer's manual for service and maintenance of the engine.

### Preventative Maintenance

1. Check to see that the water pump is properly lubricated.
2. Follow winterizing procedures to prevent freeze damage to the pump and coils.
3. Always neutralize and flush detergent from system after use.
4. If water is known to be high in mineral content, use a water softener in your water system or de-scale as needed.
5. Do not allow acidic, caustic or abrasive fluids to be pumped through system.
6. Always use high grade quality Landa cleaning products.
7. Never run pump dry for extended periods of time.
8. Use clean fuel-kerosene, No. 1 fuel oil or diesel. Replace fuel filter every 100 hours of operation. Avoid water contaminated fuel as it will seize up the fuel pump.
9. If machine is operated with smoking or eye burning exhaust, coils will soot up, not letting water reach maximum operating temperature. (See section on Air Adjustments.)
10. Never allow water to be sprayed on or near engine or burner assembly or any electrical component.

11. Periodically delime coils as per instructions.
12. Check to see that engine is properly lubricated.

It is advisable, periodically, to visually inspect the burner. Check air inlet to make sure it is not clogged or blocked. Wipe off any oil spills and keep this equipment clean and dry.

The areas around the pressure washer should be kept clean and free of combustible materials, gasoline and other flammable vapors and liquids.

The flow of combustion and ventilating air to the burner must not be blocked or obstructed in any manner.

## Maintenance And Service

### Unloader Valves

**WARNING: The unloader valve on this pressure washer has been factory set and sealed and is a field nonadjustable part. Tampering with the factory setting may cause personal injury and/or property damage, and will void the manufacturer warranty.**

**AVERTISSEMENT: La soupape de décompression sur cette laveuse à pression a été réglée en usine, puis scellée, et est une pièce non réglable. L'altération du paramètre de l'usine pourrait causer des lésions corporelles et/ou des dommages à la propriété, et annulera la garantie du fabricant**

### Winterizing Procedure

Damage due to freezing is not covered by warranty. Adhere to the following cold weather procedures whenever the washer must be stored or operated outdoors under freezing conditions.

During winter months, when temperatures drop below 32°F, protecting your machine against freezing is necessary. Store the machine in a heated room. If this is not possible then mix a 50/50 solution of anti-freeze/ water into a 5 gallon bucket. Place a short section of garden hose into the bucket and connect it to the machine. Elevate the bucket and turn the pump on to siphon the anti-freeze through the machine. If compressed air is available, an air fitting can be screwed into the inlet connector and, by injecting compressed air, all water will be blown out of the system.

### High Limit Hot Water Thermostat

For safety, each machine is equipped with a high limit control switch. In the event that the temperature of the water should exceed its operating temperature, the high limit control will turn the burner off until the water cools.

### Pumps

Use only SAE 10W-40 non-detergent oil. Change oil after the first 50 hours of use. Thereafter, change the oil every three months or at 500 hour intervals. Oil level should be checked by using the dipstick found on top of the pump or the red dot visible through the oil gauge window. Oil should be maintained at that level.

### Cleaning of Coils

In alkaline water areas, lime deposits can accumulate rapidly inside the coil pipes. This growth is increased by the extreme heat build up in the coil. The best prevention for liming conditions is to use high quality cleaning detergents. In areas where alkaline water is an extreme problem, periodic use of Landa Coil Descaler (part #8.914-296.0) will remove lime and other deposits before coil becomes plugged.

**Periodic descaling of the heating coil is recommended so please consult your local Landa Dealer for instructions.**

### Rupture Disk

If pressure from pump or thermal expansion should exceed safe limits, the rupture disk will burst allowing high pressure to be discharged through hose to ground. When disk ruptures it will need to be replaced.

### Fuel

Use clean fuel oil that is not contaminated with water and debris. Replace fuel filter and drain tank every 100 hours of operation.

Use No. 1 or No. 2 Heating Oil (ASTM D306) only. **NEVER** use gasoline in your burner tank. Gasoline is more combustible than fuel oil and a serious explosion could result. **NEVER** use crankcase or waste oil in your burner. Fuel unit malfunction could result from contamination.

### Fuel Control System

These machines utilize a fuel solenoid valve located on the fuel pump to control the flow of fuel to the combustion chamber. This solenoid valve, which is normally closed, is activated by a flow switch when water is flowing through it. When an operator releases the trigger on the spray gun, the flow of water through the flow switch stops, turning off the current to the fuel solenoid. The solenoid then closes, shutting off the supply of fuel to the combustion chamber. Controlling the flow of fuel in this way allows for an instantaneous burn or no burn situation, thereby eliminating high and low water temperatures, and combustion smoke normally associated with machines incorporating a spray gun.

**CAUTION:** *Periodic inspection is recommended to insure that the fuel solenoid valve functions properly. This can be done by operating the machine and checking to see that when the trigger on the spray gun is in the off position, the burner is not firing.*

**ATTENTION:** *Une inspection périodique est recommandée pour assurer que l'électrovalve d'alimentation en carburant fonctionne correctement. Cela peut être effectué en utilisant la machine et en s'assurant que le brûleur n'est pas allumé lorsque le pistolet pulvérisateur se trouve en position d'arrêt.*

### Burner Nozzle

The oil burner on this machine is preset for operation at altitudes below 500 feet. If operated at higher altitudes, it may be necessary to adjust the air band for a #1 or #2 smoke spot on the Bacharach scale.

To adjust, start machine and turn burner ON. Loosen two locking screws found on the air band and close air band until black smoke appears from burner exhaust vent. Note air band position. Next, slowly open the air band until white smoke just starts to appear. Turn air band halfway back to the previously noted position. Tighten locking screws.

For higher altitudes, the air band opening may need to be increased; for lower altitude, the air band may need to be decreased.

For higher humidity, the air band opening may need to be increased; for lower relative humidity, the air band may need to be decreased.

For higher ambient temperatures the air band opening may need to be increased; for lower ambient temperatures, the air band opening may need to be decreased.

Adjust to your operating location's environment as needed for best smoke spot and performance compliant with local, state, and federal regulations.

### Landa MHC Oil Burner

**Burner Air Adjustment:** To adjust fuel pressure, First install a pressure gage into the port just after the pump fuel exit. Turn the adjusting screw (located at the regulator port) clockwise to increase, and counterclockwise to decrease. Do not exceed 200 psi or lower the pressure below 130 PSI, when checked at the post-pump pressure port.

The fuel pressure may need to be adjusted due to altitude. For every 500 ft altitude above sea level, the boiling point of water goes down 1 °F. At high altitude environments, this boiling point change may require the heat input to be lowered so the water input does not turn to steam earlier than at the factory settings and activate the pressure sensors and pressure relief equipment when the unit is operated and much higher altitudes from factory settings or local dealer site settings. Check with your dealer before making local site fuel pressure adjustments.

Also, as ambient temperature changes seasonally, the fuel temperature in the feed tank and air temperature inlet can impact fuel flow. In more extreme temperatures, this local-site adjustment may also require different fuel nozzles for fuel inlet temperatures that are at seasonal extremes (higher or lower) in locations where the temperature changes are beyond moderate temperatures of between 40°F and 90°F. Colder temperatures will make for a thicker flow and less fine a fuel spray while hotter temperatures will make for a thinner flow a more fine spray with the same nozzle. Consider alternate nozzle configurations from the baseline factory-supplied nozzle for operating in such temperature extremes if performance is not meeting needs with air band and fuel pressure settings alone.

**NOTE:** *When changing fuel pump, a by-pass plug must be installed in return line port or fuel pump will not prime.*

### Landa MHC Burner Air Adjustment

**CAUTION:** *If white smoke appears from burner exhaust vent during start-up or operation, discontinue use and readjust air bands.*

**ATTENTION:** *Si de la fumée blanche s'échappe de l'évacuation du brûleur pendant le démarrage ou le fonctionnement, cesser d'utiliser et réajuster les bandes d'air.*

**NOTE:** If a flue is installed, have a professional serviceman adjust your burner for a #1 or #2 smoke spot on the Bacharach scale.



## Removal of Soot and Heating Coil

In the heating process, fuel residue in the form of soot deposits may develop on the heating coil and block air flow which will affect burner combustion. When soot has been detected on visual observation, the soot on the coil must be washed off after following the coil removal steps.

1. Remove the tank head assembly by unscrewing six screws and lifting the top wrap off.
2. Fold back insulation blanket.
3. Remove the two pipe nipples and associated fittings.
4. Remove bolt Item 75.
5. Lift the coil out of the bottom wrap.

**CAUTION: The coil weighs about 80 lbs. Use proper lifting techniques.**

**ATTENTION: La bobine pèse environ 36.3 kg (80lb). Utiliser des techniques de levage appropriées.**

6. Clean, repair and replace the coil by reversing the above steps.

## Coil Re-installation

Reinstall by reversing the above steps 6 through 1.

## Final Note

The 12 VDC burner systems can draw as much as 18 amps! For such motors to run properly, the battery and engine charging system must be kept in good condition, and the engine must run fast enough to adequately charge the battery. Do not throttle down the engine for any length of time.

## Maintenance

### Troubleshooting

PROBLEM	POSSIBLE CAUSE	SOLUTION
<b>LOW OPERATING PRESSURE</b>	Water supply is insufficient	Use larger supply hose; clean filter at water inlet.
	Spray nozzle is old, worn or incorrect	Match the nozzle number to the machine and/or replace with new nozzle.
	Belt slips	Tighten or replace belt; use correct belt.
	Plumbing or hose is leaking	Check plumbing system for leaks. Re-tape leaks with teflon tape.
	Unloader is faulty or mis-adjusted	Adjust unloader for proper pressure. Install repair kit when necessary or replace.
	Packing in pump is worn	Install new packing kit.
	Discharge valve in pump or inlet is fouled or dirty	Check inlet and discharge valve.
	Discharge valve or inlet is worn	Replace with valve kit.
	Spray nozzle has obstruction	Remove obstruction.
	Steam pressure control valve is leaking (where applicable)	Rebuild or replace as necessary.
	Engine RPM is slow	Set engine speed at proper specifications. See serial plate. The gasoline engine is preset for operation at altitudes below 1000 feet above sea level. If operated at higher altitudes, it may be necessary to install a high altitude main jet in the carburetor. Contact your local authorized engine sales and service center for details.
<b>BURNER WILL NOT LIGHT</b>	There is little or no fuel	Fill tank with fuel.
	Improper fuel or water in fuel	Drain fuel tank and fill with proper fuel.
	Fuel line is clogged	Clean or replace fuel line.
	Fuel filter is plugged	Replace fuel filter as needed.
	Burner air bands are mis-adjusted	Readjust air bands for clean burn.
	Little or no fuel pressure from fuel pump	Increase fuel pressure to specification and/or replace fuel pump.
	Burner transformer is faulty	Test transformer for proper arc between contacts. Replace as needed.
	Electrical wiring is disconnected or has short in it	All wire contacts should be clean and tight with no breaks in wire.
	Flex coupling is slipping on fuel pump shaft or burner motor shaft	Replace if needed.
	ON-OFF switch is defective	Check for electrical current reaching burner assembly with burner switch on. Replace switch if needed.
	Heavy sooting on coil and burner can cause interruption of air flow and shorting of electrodes	Clean as required.
	Electrode setting is improper	Check and reset according to diagram in manual.
	30 amp circuit breaker tripped	Push in reset button.
	Bridge rectifier defective	Test and replace.
	12V DC relay defective	Test and replace.
Fuel is not reaching combustion chamber	Check fuel pump for proper flow. Check solenoid flow switch on machines with spray gun control for proper on-off flow control.	

<b>PROBLEM</b>	<b>POSSIBLE CAUSE</b>	<b>SOLUTION</b>
<b>BURNER WILL NOT LIGHT</b>	Burner nozzle is clogged	Clean as required.
	Thermostat has malfunctioned	Test and replace if needed.
	Fuel solenoid has malfunctioned	Test and replace if needed.
<b>MACHINE SMOKES WHILE BURNER UNIT IS RUNNING OR UNIT SMOKES AT COLD-START ONLY WHEN BURNER IS OFF</b>	Fuel is improper or water is in fuel	Drain tank and replace contaminated fuel.
	Air adjustment is improper	Readjust air bands on burner assembly.
	Fuel pressure is low 140 psi for burner	Adjust fuel pump pressure to specifications.
	Burner nozzle is plugged or dirty	Replace nozzle. Check parts breakdown for nozzle size.
	Burner nozzle spray pattern is faulty	Replace nozzle. Check parts breakdown for nozzle size.
	Coil and burner assembly have heavy accumulation of soot	Remove coils and burner assembly, clean thoroughly. Call local dealer.
	Electrode setting is misaligned	Realign electrodes to specifications.
	Smoke stack has obstruction	Check for blockage or other foreign objects.
	Engine RPM is low	Increase RPM to correct specs. See serial plate.
	Fuel Pressure is too high for clean burn (fuel PSI above 140 and below 200) and smokes when burner is off	Reduce fuel pressure PSI/Increase air band set for cleaner without max water heat loss
<b>LOW WATER TEMPERATURE</b>	Fuel is improper or has water in it	Replace with clean and proper fuel.
	Fuel pressure is low	Increase fuel pressure.
	Fuel pump is weak	Check fuel pump pressure. Replace pump if needed.
	Fuel filter is partially clogged	Replace as needed.
	Soot buildup on coils is not allowing heat transfer	Clean coils.
	Burner nozzle is improper	Call your local dealer for proper nozzle.
<b>WATER TEMPERATURE TOO HOT</b>	Incoming water to machine is warm or hot	Lower incoming water temperature.
	Fuel pump pressure is too high	Call your local dealer for proper fuel pressure.
	Fuel pump is defective	Replace fuel pump.
	Fuel nozzle is incorrect size	See parts breakdown or serial plate for proper size.
	Water supplied is insufficient	Check water GPM to machine.
	Water flow is restricted	Check nozzle for obstruction and proper size. Check serial plate for correct size.
<b>PRESENCE OF WATER IN OIL</b>	Oil seal is worn	Check and replace if necessary.
	Air humidity is high	Check and change oil twice as often.
	Packing is worn or bad	Check and replace if necessary.
<b>DETERGENT NOT DRAWING</b>	Air is leaking	Tighten all clamps. Check detergent lines for holes.
	Filter screen on detergent suction hose is plugged	Clean or replace.
	Detergent has high viscosity	Dilute detergent to specifications.

## Maintenance

PROBLEM	POSSIBLE CAUSE	SOLUTION
<b>DETERGENT NOT DRAWING CONT.</b>	Injector head may be blocked, dirty or damaged.	Clean and make sure ball and spring behind detergent hose barb or injector body are working properly.
	Not using soap nozzle	Insert soap nozzle into wand coupler.
	Detergent level is low	Add detergent if needed.
<b>PUMP RUNNING NORMALLY BUT PRESSURE LOW ON INSTALLATION</b>	Pump is sucking air	Check water supply and possibility of air seepage.
	Valves are sticking	Check and clean or replace if necessary.
	Unloader valve seat is faulty	Check and replace if necessary.
	Nozzle sized incorrectly	Check and replace if necessary (see serial plate for proper size).
	Packing piston is worn	Check and replace if necessary.
<b>FLUCTUATING PRESSURE</b>	Valves are worn	Check and replace if necessary.
	Valve has a blockage	Check and replace if necessary.
	Pump is sucking air	Check water supply and air seepage at joint in suction line.
	Packing piston is worn	Check and replace if necessary.
	Gasoline Engine Altitude	The gasoline engine is preset for operation at altitudes below 1000 feet above sea level. If operated at higher altitudes, it may be necessary to install a high altitude main jet in the carburetor. Contact your local authorized engines sales and service center for details.
<b>PUMP NOISY</b>	Air is in suction line	Check water supply and connections on suction line.
	Inlet or discharge valve springs are weak or broken	Check and replace if necessary.
	Excessive matter is in valves	Check and replace if necessary.
	Bearings are worn	Check and replace if necessary.
<b>WATER DRIPPING FROM UNDER PUMP</b>	Piston packing is worn	Check and replace if necessary.
	O-Ring plunger retainer is worn	Check and replace if necessary.
	Piston is cracked	Check and replace if necessary.
	Pump protector is worn	Lower water supply pressure. Do not run the spray gun closed longer than 5 minutes.
<b>OIL DRIPPING</b>	Oil seal is worn	Check and replace if necessary.
<b>EXCESSIVE VIBRATION IN DELIVERY LINE</b>	Valves are functioning irregularly	Check and replace if necessary.
<b>BURNER MOTOR WILL NOT RUN</b>	Fuel pump has seized	Replace fuel pump.
	Burner fan loose or misaligned	Position correctly and tighten set screw.
	Control switch is defective	Replace switch.
	There is a loose wire	Check and replace or tighten wiring.
	Burner motor is defective	Replace motor.
<b>RELIEF VALVE LEAKS WATER</b>	Relief valve is defective	Replace or repair relief valve.

**Preventative Maintenance**

This pressure washer was produced with the best available materials and quality craftsmanship. However, you as the owner have certain responsibilities for the correct care of the equipment. Attention to regular preventative maintenance procedures will assist in preserving the performance of your equipment. Contact your dealer for maintenance. Regular preventative maintenance will add many hours to the life of your pressure washer. Perform maintenance more often under severe conditions.

<b>MAINTENANCE SCHEDULE</b>		
Pump Oil (non-foaming) SAE 10W-40	Inspect	Oil level daily
	Change	After first 50 hours, then every 500 hours or annually
Replace High Pressure Nozzle		Every 6 months
Replace Quick Connects		Annually
Clean Water Screen/Filter		Weekly
Replace HP Hose		Annually
Replace Burner Nozzle		Annually
Engine oil - See engine manual		Check oil level daily

**Oil Change Record**

Check pump oil level before first use of your new Power Washer. Change pump oil after first 50 hours and every month or 500 hours thereafter. Use SAE 10W-40 non-foaming oil.

<b>Date Oil Changed Month/Day/Year</b>	<b>Estimated Operating Hours Since Last Oil Change</b>

<b>Date Oil Changed Month/Day/Year</b>	<b>Estimated Operating Hours Since Last Oil Change</b>

***LANDA***<sup>®</sup>

9.800-950.0 • Printed in U.S.A.