

**1800/5700/5800 Series**  
**Hot Water - Electric - Gas Fired**

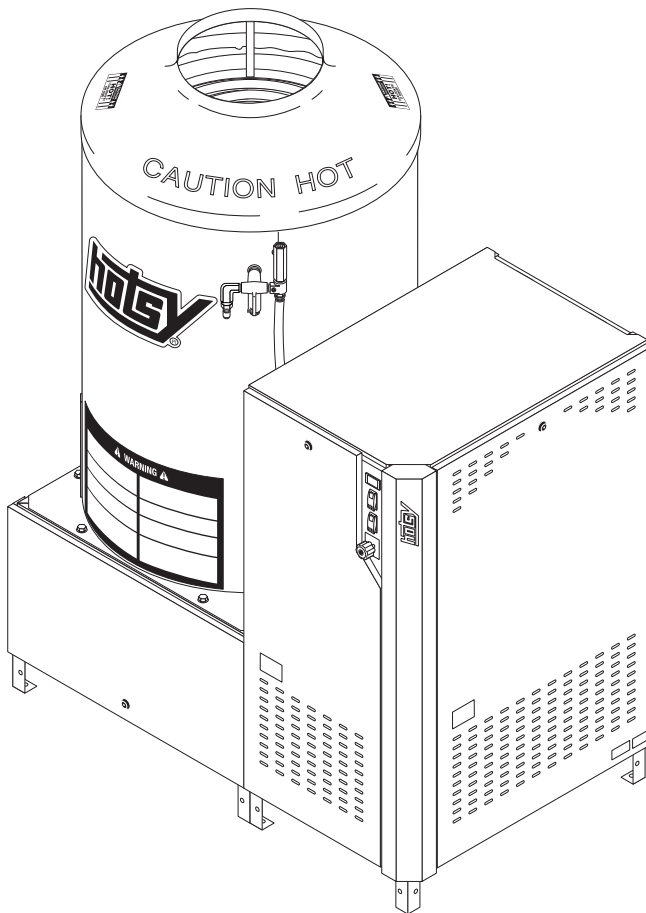

**Operator's Manual**

**Stationary Pressure Washer**



**MODELS:**

<b>1812SS</b>	<b>5732SS-208</b>
<b>1.109-660.0</b>	<b>1.109-654.0</b>
	<b>5732SS</b>
<b>1832SS-208</b>	<b>1.109-655.0</b>
<b>1.109-661.0</b>	
	<b>5735SS</b>
<b>1832SS</b>	<b>1.109-656.0</b>
<b>1.109-662.0</b>	
	<b>5736SS</b>
<b>1835SS</b>	<b>1.109-657.0</b>
<b>1.109-663.0</b>	
	<b>5832SS-208</b>
<b>1836SS</b>	<b>1.109-650.0</b>
<b>1.109-664.0</b>	
	<b>5832SS</b>
	<b>1.109-651.0</b>
	<b>5835SS</b>
	<b>1.109-652.0</b>
	<b>5836SS</b>
	<b>1.109-653.0</b>

Scan or Click to View  
The Hotsy Safety Video



For the Hotsy Dealer nearest you,  
consult our web page at  
[www.hotsy.com](http://www.hotsy.com)



Intertek



9.808-037.0-C

10/31/24

## **Machine Data Label**

Model: \_\_\_\_\_

Date of Purchase: \_\_\_\_\_

Serial Number: \_\_\_\_\_

Dealer: \_\_\_\_\_

Address: \_\_\_\_\_

Phone Number: \_\_\_\_\_

Sales Representative: \_\_\_\_\_

### **IMPORTANT**

If the pressure washer demonstrates other symptoms or the corrective actions listed do not correct the problem, contact the local authorized Hotsy Service Center. The Hotsy Service Center can be identified by visiting [www.hotsy.com](http://www.hotsy.com).

**When ordering from your dealer, please provide the following:**

**Model Number:** \_\_\_\_\_ **Date of Purchase:** \_\_\_\_\_

**Machine Serial Number:** \_\_\_\_\_

**Component Part Number:** \_\_\_\_\_

**Description:** \_\_\_\_\_

The model and serial numbers will be found on a decal attached to the pressure washer. You should record both serial number and date of purchase and keep in a safe place for future reference.

#### **GAS-FIRED SERIES OPTIONAL EQUIPMENT**

**1800 Series Draft Diverter-10" 9.801-040.0**

**5700 Series Draft Diverter-12" 8.717-730.0**

**5800 Series Draft Diverter-12" 8.717-730.0**

**Machine Data Label . . . . .2**  
**Table of Contents . . . . .3**  
**How To Use This Manual . . . . .4**

**Safety**

Introduction & Safety Information . . . . .5  
IMPORTANT SAFETY INFORMATION . . . . .6  
Propane Tank Safety Instructions. . . . .9

**Operations**

Technical Specifications . . . . .10  
Component Identification . . . . .12  
Assembly Instructions . . . . .13  
Installation Instructions . . . . .14  
Getting Started . . . . .14  
Location . . . . .14  
Electrical . . . . .14  
Gas Burner . . . . .15  
Natural Gas Fuel. . . . .15  
Gas Codes . . . . .16  
Gas Piping . . . . .16  
Pipe Sizing Chart for Natural Gas. . . . .16  
LP-Gas (Liquid Petroleum Gas or Propane). . . . .16  
Filling the LP-Gas Container. . . . .17  
Propane Tank Disposal. . . . .17  
Venting . . . . .17  
Exhaust Stack. . . . .18  
Water Source . . . . .19  
Start-Up. . . . .22  
Check List Before Starting . . . . .23  
Operation Instructions. . . . .24  
Cleaning Techniques . . . . .25  
Storage . . . . .25

**Maintenance**

Pump. . . . .26  
Pump Motor . . . . .26  
Pressure Relief Valve . . . . .26  
Unloader Valve . . . . .26  
Heating Coil . . . . .26  
Troubleshooting . . . . .27

## ***How To Use This Manual***

This manual contains the following sections:

- How to Use This Manual
- Safety
- Operations
- Maintenance

The HOW TO USE THIS MANUAL section will tell you how to find important information for ordering correct repair parts.

Parts may be ordered from authorized dealers. When placing an order for parts, the machine model and machine serial number are important. Refer to the MACHINE DATA box which is filled out during the installation of your machine. The MACHINE DATA box is located on the inside of the front cover of this manual.

Model:	_____
Date of Purchase:	_____
Serial Number:	_____
Dealer:	_____
Address:	_____
Phone Number:	_____
Sales Representative:	_____

The model and serial number of your machine is located on the back of the machine.

The SAFETY section contains important information regarding hazardous or unsafe practices of the machine. Levels of hazards are identified that could result in product damage, personal injury, or severe injury resulting in death.

The OPERATIONS section is to familiarize the operator with the operation and function of the machine.

The MAINTENANCE section contains preventive maintenance to keep the machine and its components in good working condition. They are listed in this general order:

- Pump
- Heating Coil
- Troubleshooting

## **Introduction & Safety Information**

Thank you for purchasing this Pressure Washer.

We reserve the right to make changes at any time without incurring any obligation.

### **Owner/User Responsibility:**

The owner and/or user must have an understanding of the manufacturer's operating instructions and warnings before using this pressure washer. Warning information should be emphasized and understood. If the operator is not fluent in English, the manufacturer's instructions and warnings shall be read to and discussed with the operator in the operator's native language by the purchaser/owner, making sure that the operator comprehends its contents.

Owner and/or user must study and maintain for future reference the manufacturers' instructions.

The operator must know how to stop the machine quickly and understand the operation of all controls. Never permit anyone to operate the engine without proper instructions.

### **SAVE THESE INSTRUCTIONS**

**This manual should be considered a permanent part of the machine and should remain with it if machine is resold.**

**When ordering parts, please specify model and serial number. Use only identical replacement parts. This machine is to be used only by trained operators**

### IMPORTANT SAFETY INFORMATION

**WARNING:** If you do not follow these instructions exactly, a fire or explosion may result, causing property damage, personal injury or loss of life.

**AVERTISSEMENT:** Si ces directives ne sont pas suivies à la lettre, un incendie ou une explosion pourrait survenir et entraîner des dommages à la propriété, des lésions corporelles ou la mort.

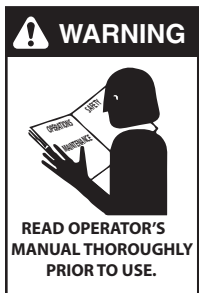

**WARNING:** To reduce the risk of injury, read operating instructions carefully before using.

**AVERTISSEMENT:** Pour réduire le risque de blessures, lire attentivement les instructions de fonctionnement avant l'utilisation.

1. Read the owner's manual thoroughly. Failure to follow instructions could cause malfunction of the machine and result in death, serious bodily injury and/or property damage.
2. Know how to stop the machine and bleed pressure quickly. Be thoroughly familiar with the controls.
3. Stay alert — watch what you are doing.
4. All installations must comply with local codes. Contact your electrician, plumber, utility company or the selling dealer for specific details.

**DANGER:** Improper connection of the equipment-grounding conductor can result in a risk of electrocution. Check with a qualified electrician or service personnel if you are in doubt as to whether the outlet is properly grounded.

**DANGER:** Une mauvaise connexion du conducteur de terre de l'équipement peut entraîner un risque d'électrocution. Vérifier auprès d'un électricien qualifié ou du personnel d'entretien si vous avez des doutes quant à savoir si la sortie est correctement mise à la masse.



**DANGER:** Keep wand, hose, and water spray away from electric wiring or fatal electric shock may result.

**DANGER:** Garder la lance, le boyau et le jet d'eau à l'écart de tout câblage électrique ou des chocs électriques mortels pourraient survenir.

5. To protect the operator from electrical shock, the machine must be electrically grounded. It is the responsibility of the owner to connect this machine to a UL grounded receptacle of proper voltage and amperage ratings. Do not spray water on or near electrical components. Do not touch machine with wet hands or while standing in water. Always disconnect power before servicing.

**WARNING:** Flammable liquids can create fumes which can ignite, causing property damage or severe injury.

**AVERTISSEMENT:** Des liquides inflammables peuvent produire des vapeurs qui peuvent s'enflammer, causant ainsi des dommages à la propriété ou des blessures graves.



**WARNING:** Risk of explosion — Do not Spray flammable liquids. Operate only where open flame or torch is permitted.

**AVERTISSEMENT:** Risque d'explosion - Ne pas pulvériser de liquides inflammables. Utiliser uniquement dans des endroits où l'utilisation d'une flamme nue ou d'une torche est permise.

**WARNING:** Risk of fire — Do not change tanks when the product is operating or still hot.

**AVERTISSEMENT:** Risque d'incendie - Ne pas changer les réservoirs pendant que le produit est en marche ou encore chaud.

**WARNING:** Use vapor fuel only.

**AVERTISSEMENT:** Utiliser des vapeurs de carburant seulement.

6. The LP models are designed to run on vapor propane fuel. Do not use liquid fuel. Have a qualified serviceman install and service your equipment.
7. Keep operating area clear of all persons.



**DANGER:** Risk of asphyxiation. Use this product only in a well ventilated area.

**DANGER:** Risque d'asphyxie. Utiliser ce produit uniquement dans un endroit bien ventilé.



**WARNING:** High pressure spray can cause paint chips or other particles to become airborne and fly at high speeds. To avoid personal injury, eye, hand and foot safety devices must be worn.

**AVERTISSEMENT:** Un jet haute pression peut écailler la peinture ou provoquer l'émission d'autres particules dans l'air et leur

projection à hautes vitesses. Pour éviter les lésions corporelles, une protection des yeux, du visage, des mains et des pieds doit être portée lors de l'utilisation de cet équipement.

8. Wear properly rated eye protection such as safety goggles or face shield while spraying.

(Safety glasses do not provide full protection.)



**CAUTION:** Hot discharge fluid. Do not touch or direct discharge stream at persons or animals.

**ATTENTION:** Liquide de décharge chaud. Ne pas toucher ou décharger directement le jet vers des personnes ou des animaux

**WARNING:** This machine produces hot water and must have insulated components

attached to protect the operator.

**AVERTISSEMENT:** Cette machine produit de l'eau chaude et doit comporter des composants isolés attachés pour protéger l'opérateur.



**WARNING:** Risk of injury. Hot surfaces can cause burns. Use only designated gripping areas of spray gun and wand. Do not place hands or feet on non-insulated areas of the pressure washer.

**AVERTISSEMENT:** Risque de blessures. Les surfaces chaudes peuvent causer des brûlures.

Utiliser uniquement les zones de prise désignées du pistolet pulvérisateur et de la lance. Ne pas placer les mains ou les pieds sur des endroits non isolés de la laveuse à pression.

9. To reduce the risk of injury, close supervision is necessary when a machine is used near children. Do not allow children to operate the pressure washer. **This machine must be attended during operation.**



**WARNING:** Grip cleaning wand securely with both hands before starting. Failure to do this could result in injury from a whipping wand.

**AVERTISSEMENT:** Agripper la lance de nettoyage avec les deux mains avant de commencer. Le non-respect de cette consigne pourrait mener à des blessures

causées par le mouvement violent de la lance.

10. Never make adjustments on machine while in operation.
11. Be certain all quick coupler fittings are secured before using pressure washer.



**WARNING:** High pressure developed by these machines will cause personal injury or equipment damage. Keep clear of nozzle. Use caution when operating. Do not direct discharge stream at people or animals or severe injury or death will result.

**AVERTISSEMENT:** La haute pression générée par ces machines causera des lésions corporelles ou des dommages à l'équipement. Se tenir à l'écart de la buse. Faire preuve de prudence lors de l'utilisation. Ne pas décharger directement le jet vers des personnes ou des animaux, car cela risquerait de causer des blessures graves ou même la mort



**WARNING:** Protect machine from freezing.

**AVERTISSEMENT:** Protéger la machine contre le gel.

12. To keep machine in best operating conditions, it is important you protect machine from freezing. Failure to protect machine from freezing could cause malfunction of

the machine and result in death, serious bodily injury, and/or property damage. Follow storage instructions specified in this manual.

13. Inlet water must be clean fresh water and no hotter than 90°F.

## Safety

14. Avoid installing machines in small areas or near exhaust fans. Adequate oxygen is needed for combustion or dangerous carbon monoxide will result.
15. Manufacturer will not be liable for any changes made to our standard machines or any components not purchased from us.
16. The best insurance against an accident is precaution and knowledge of the machine.



**WARNING:** Be extremely careful when using a ladder, scaffolding or any other relatively unstable location. The cleaning area should have adequate slopes and drainage to reduce the possibility of a fall due to slippery surfaces.

**AVERTISSEMENT:** Faire preuve d'une extrême prudence au moment d'utiliser une échelle,

des échafaudages ou toute autre surface relativement instable. La zone de nettoyage doit avoir une pente et un drainage adéquats pour réduire la possibilité d'une chute due à une surface glissante.

17. Do not overreach or stand on unstable support. Keep good footing and balance at all times.
18. Do not operate this machine when fatigued or under the influence of alcohol, prescription medications, or drugs.
19. When making repairs disconnect from electrical source and shut off gas valve.
20. Never expose a spark or flame where there may be unburned gas present.

**CAUTION:** Electric products incorporate parts that produce sparks and therefore when located in a garage, it should be in a room or enclosure provided for the purpose, or should be 18" (45cm) or more above the floor. Install on non combustible flooring and have a 36" (90cm) minimum working clearance.

**ATTENTION:** Les produits électriques comportent des pièces qui ont tendance à produire des étincelles et, par conséquent, lorsqu'ils se trouvent dans un garage, il devrait s'agir d'une pièce ou d'une enceinte conçue à cette fin ou devraient se situer à 45 cm (18 po) ou plus au-dessus du sol. Installer un sol non combustible et fournir un espace de travail d'au moins 90 cm (36 po).

21. Do not allow acids, caustic or abrasive fluids to pass through the pump.
22. Never run pump dry or leave spray gun closed longer than 1-2 minutes.



**WARNING:** If connection is made to portable water supply, a back flow device must be provided.

**AVERTISSEMENT:** Si une connexion est établie avec un approvisionnement en eau potable, un dispositif de protection contre le retour d'eau doit être fourni.



**WARNING:** Do not spray machine or any people, animals or electrical parts.

**AVERTISSEMENT:** Ne pas vaporiser sur la machine ou les gens, les animaux ou les pièces électriques.

23. Exhaust gases should not be vented into a wall, a ceiling or a concealed space within a building. A draft diverter must be installed to prevent down draft and to allow for the cooling of exhaust temperatures. It is recommended to install the draft diverter 36" above the pressure washer stack; however, it can be installed at a lower height in special cases, such as when low ceilings are present. The draft diverter being right on top of the machine in cold freezing environments could potentially allow the coil to be frozen and damage the coil. Check local codes and standards for specific installation requirements. Exhaust gases that exceed 470°F (243°C) are not suitable for connection to Type B gas vents
24. Before disconnecting discharge hose from water outlet, turn burner off and open spray gun to allow water to cool below 100° before stopping the machine. Then open the spray gun to relieve pressure. Failure to properly cool down or maintain the heating coil may result in a steam explosion.



**Follow the maintenance instructions specified in the manual.**

**Suivre les instructions d'entretien spécifiées dans le manuel.**

## Propane Tank Safety Instructions

**CAUTION:** Only qualified persons should fill your LP-gas containers.

**ATTENTION:** Les contenants de gaz de pétrole liquéfié doivent être remplis uniquement par des personnes qualifiées.

1. Never allow your LP-gas container to be filled above the maximum safe level as indicated by a scale or the fixed liquid level gauge (outage). Do not use the visible gauge for filling.
2. Do not use a wrench or pliers to close the service valve or fixed liquid level gauge. These valves are designed to be closed leak-tight by hand or screwdriver as appropriate. If wrenches are necessary to stop a leak, the valve needs repair or replacement.
3. When tightening the POL Nut (left hand thread) on the service valve, draw it up snug with a proper wrench. This is a machined male brass fitting which seats securely against a female seat in the POL valve – no pipe dope is necessary. Acme/Type 1 valves have right handed threads which are secure when hand tight, and on the Quick Disconnect/Type 2 Valves, the male connection is inserted into the female connection on the cylinder valve. (No wrenches required for both the Acme and the Quick Disconnect.)
4. When using container, slowly open service valve all the way. Listen to the regulator. A continuous hiss may indicate a leak or an open valve on an appliance.
5. Check all tank and the line connections periodically to be sure they are tight. When testing for leaks, use approved leak detector solution – not matches.
6. Make certain your container is properly fastened in place.
7. Turn container with open part of container guard towards frame. This protects valves and regulator against flying rocks and mud. Transport container in the proper position in which it is used, with the valves closed and POL Plugs inserted for POL Valves or Dust Caps for Acme Valves. Secure the tank against falling or rolling.
8. Check for leaks after connecting. Apply approved leak detector solution to connection, turn off all burners and pilots, and open service valve. Leaks will be detected by the growth of the bubbles. If bubbles grow, tighten or repair the connection as needed. Repeat leak test until problem is corrected.
9. LP-gas is normally non-corrosive – you need not worry about the inside of your container. However, the outside should be kept free from rust by a periodic coat of paint in a light reflective color. It is very important to inspect and maintain the bottom and foot ring on the container.
10. Do not store LP-gas containers indoors or in enclosed areas. Do not expose LP-gas container to heat. Always store with service valve closed and plugged as required.
11. Do not attempt to repair any containers, container valves, regulator or appliances by yourself. Use only trained certified LP-gas service personnel to perform repairs.

## Operations

### Technical Specifications

Model	Model #	Pump Volume @ Pump Head	Pump Pressure at Pump Head	Burner Type	Machine Voltage
1812SS	1.109-660.0	5.9 GPM / 354 GPH	2500 PSI	Natural Gas Fired 558, 050 BTU/Hr	230VAC/ 60Hz/1Ph
1832SS	1.109-662.0	6.0 GPM / 360 GPH	3000 PSI	Natural Gas Fired 558, 050 BTU/Hr	230VAC/ 60Hz/3Ph
1832SS-208	1.109-661.0	6.0 GPM / 360 GPH	3000 PSI	Natural Gas Fired 558, 050 BTU/Hr	200VAC/ 60Hz/3Ph
1835SS	1.109-663.0	6.0 GPM / 360 GPH	3000 PSI	Natural Gas Fired 558, 050 BTU/Hr	460VAC/ 60Hz/3Ph
1836SS	1.109-664.0	6.0 GPM / 360 GPH	3000 PSI	Natural Gas Fired 558, 050 BTU/Hr	575VAC/ 60Hz/3Ph
5732SS-208	1.109-654.0	7.8 GMP/ 470 GPH	3000 PSI	Natural Gas Fired 720, 450 BTU/Hr	208VAC/ 60Hz/3Ph
5732SS	1.109-655.0	7.8 GMP/ 470 GPH	3000 PSI	Natural Gas Fired 720, 450 BTU/Hr	230VAC/ 60Hz/3Ph
5735SS	1.109-656.0	7.8 GMP/ 470 GPH	3000 PSI	Natural Gas Fired 720, 450 BTU/Hr	460VAC/ 60Hz/3Ph
5736SS	1.109-657.0	7.8 GMP/ 470 GPH	3000 PSI	Natural Gas Fired 720, 450 BTU/Hr	575VAC/ 60Hz/3Ph
5832SS	1.109-651.0	9.5 GPM/570 GPH	2500 PSI	Natural Gas Fired 939,890 BTU/Hr.	230VAC/ 60Hz/3Ph
5832SS-208	1.109-650.0	9.5 GPM/570 GPH	2500 PSI	Natural Gas Fired 939,890 BTU/Hr.	208VAC/ 60Hz/3Ph
5835SS	1.109-652.0	9.5 GPM/570 GPH	2500 PSI	Natural Gas Fired 939,890 BTU/Hr.	460VAC/ 60Hz/3Ph
5836SS	1.109-653.0	9.5 GPM/570 GPH	2500 PSI	Natural Gas Fired 939,890 BTU/Hr.	575VAC/ 60Hz/3Ph

<b>Model #</b>	<b>Total Machine Amperage</b>	<b>Machine Weight</b>	<b>Shipping Weight</b>	<b>Exhaust Stack Size</b>	<b>Machine Dimensions</b>
<b>1812SS</b>	42 Amps	825 Lbs	1070 Lbs	10"	L 51" X W 31" X H 54"
<b>1832SS</b>	38 Amps	825 Lbs	1070 Lbs	10"	L 51" X W 31" X H 54"
<b>1832SS-208</b>	41 Amps	825 Lbs	1070 Lbs	10"	L 51" X W 31" X H 54"
<b>1835SS</b>	19 Amps	825 Lbs	1070 Lbs	10"	L 51" X W 31" X H 54"
<b>1836SS</b>	16 Amps	825 Lbs	1070 Lbs	10"	L 51" X W 31" X H 54"
<b>5732SS-208</b>	55 Amps	1016 Lbs	1260 Lbs	12"	L 51" X W 31" X H 54"
<b>5732SS</b>	42 Amps	1016 Lbs	1260 Lbs	12"	L 51" X W 31" X H 54"
<b>5735SS</b>	21 Amps	1016 Lbs	1260 Lbs	12"	L 51" X W 31" X H 54"
<b>5736SS</b>	16 Amps	1016 Lbs	1260 Lbs	12"	L 51" X W 31" X H 54"
<b>5832SS</b>	42 Amps	1035 Lbs	1275 Lbs	12"	L 51" X W 31" X H 54"
<b>5832SS-208</b>	48 Amps	1035 Lbs	1275 Lbs	12"	L 51" X W 31" X H 54"
<b>5835SS</b>	21 Amps	1035 Lbs	1275 Lbs	12"	L 51" X W 31" X H 54"
<b>5836SS</b>	16 Amps	1035 Lbs	1275 Lbs	12"	L 51" X W 31" X H 54"

# Operations

## Component Identification

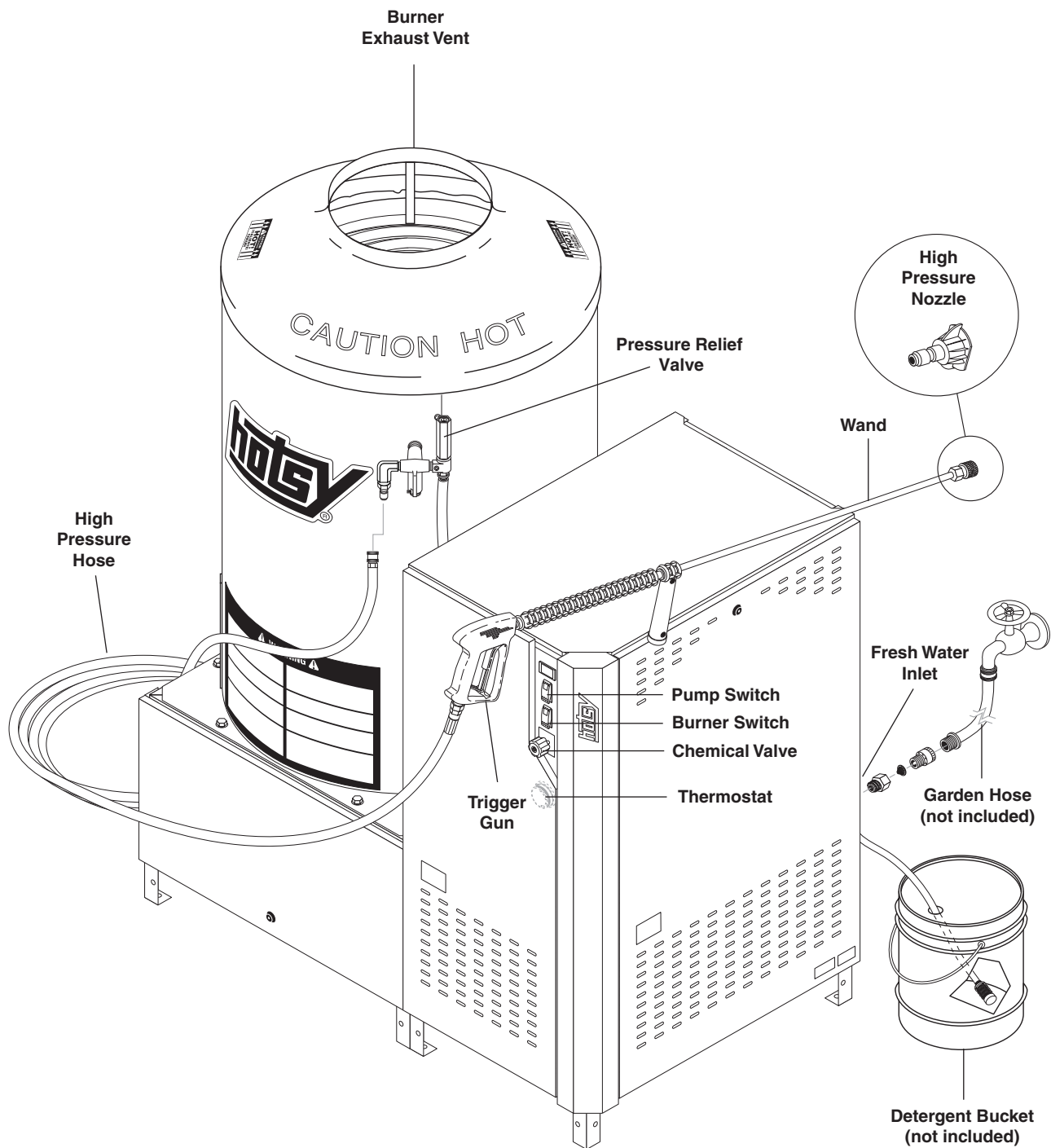

## Assembly Instructions

### Unpacking

Unpack carefully. Wear safety glasses or goggles while unpacking, assembling, or operating pressure washer. If there are missing components or hidden damage, immediately contact carrier concerning discrepancies.

1. Remove the two bolts that secure the pressure washer to the pallet.
2. Remove pressure washer from pallet.

### Parts Included

- Pressure Washer
- Pressure Hose
- Wand
- Trigger Gun
- Hose Hangers (2 Ea.)
- Operating Instructions and Parts Manual

### Tools Required

- 10" Adjustable Wrenches (2 Ea.)
- Teflon Tape

### Pressure Hose, Trigger Gun and Wand

1. When assembling, use teflon tape on all plumbing connections to prevent leakage.
2. Install the pressure hose on the pressure washer as shown.

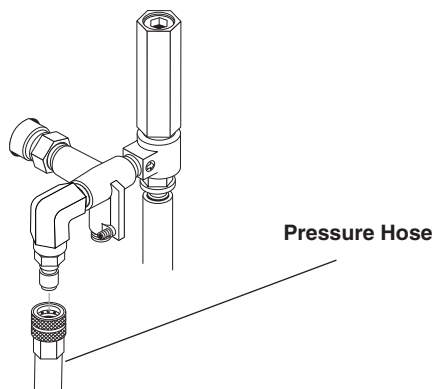

3. Assemble wand components as shown.

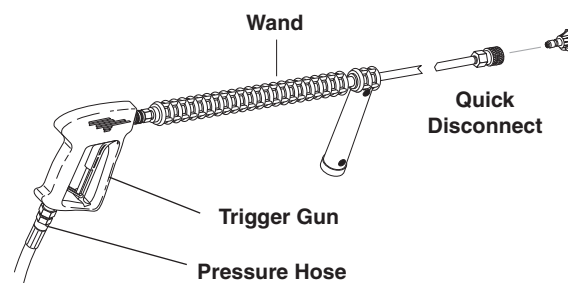

**NOTE: The pressure nozzle is not to be installed at this time.**

4. Install garden hose adapter on float tank as shown.
5. Make sure all plumbing connections are tight.

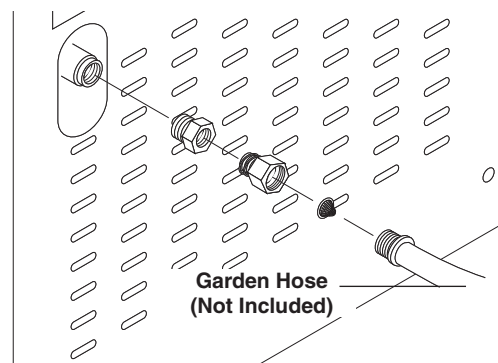

## Operations

### Installation Instructions

#### Getting Started

**IMPORTANT:** Proper initial installation of equipment will assure more satisfactory performance, longer service life, and lower maintenance cost.

**IMPORTANT:** The use of a back flow preventer on the water supply hose is recommended and may be required by local code.

#### Location

The location should protect machine from damaging environmental conditions, such as wind, rain and freezing.

1. The machine should be run on a level surface where it is not readily influenced by outside sources such as strong winds, freezing temperatures, rain, etc. The machine should be located considering accessibility for the replacing of components and the refilling of detergents, adjustments and maintenance. Normal precautions should be taken by the operator of the machine to prevent excess moisture from reaching the machine.
2. It is recommended that a partition be made between the wash area and machine to prevent direct spray from the spray gun from coming in contact with the machine. Excess moisture reaching the power unit or electrical controls will reduce the machine's life and may cause electrical shorts.
3. During installation of the machine, beware of poorly ventilated locations or areas where exhaust fans may cause an insufficient supply of oxygen. Sufficient combustion can only be obtained when there is a sufficient supply of oxygen available for the amount of fuel being burned. If it is necessary to install a machine in a poorly ventilated area, outside fresh air may have to be piped to the burner and a fan installed to bring the air into the area.
4. Do not locate near any combustible material. Keep all flammable material at least 20 feet away. Electric products incorporate parts that produce sparks and therefore when located in a garage, it should be in a room or enclosure provided for the purpose, or should be 18" (45cm) or more above the floor. Install on non combustible flooring and have a 36" (90cm) minimum working clearance.

Local code will require certain distances from floor and walls.

**WARNING:** Avoid small areas or near exhaust fans.

**AVERTISSEMENT:** Éviter les petites superficies ou les surfaces à proximité des ventilateurs d'extraction

#### Electrical

**WARNING:** Make sure all switches and controls are in the OFF position prior to connecting electrical supply.

**AVERTISSEMENT:** S'assurer que tous les commutateurs et tous les contrôles se trouvent en position d'arrêt avant de raccorder l'alimentation électrique.

**WARNING:** DO NOT stand in water while connecting and disconnecting electrical supply.

**AVERTISSEMENT:** NE PAS se tenir debout dans l'eau au moment de brancher ou de débrancher l'alimentation électrique.

**CAUTION:** Hazard of electric shock - More than one disconnect switch is required to disconnect all power.

**ATTENTION:** Risque de choc électrique. - Plus d'un sectionneur est requis pour débrancher toutes les sources d'alimentation.

**CAUTION:** Use copper conductors only.

**ATTENTION:** Utiliser des conducteurs en cuivre seulement.

**IMPORTANT:** Consult local building codes for exact electrical requirements. Licensed contractors may be required.

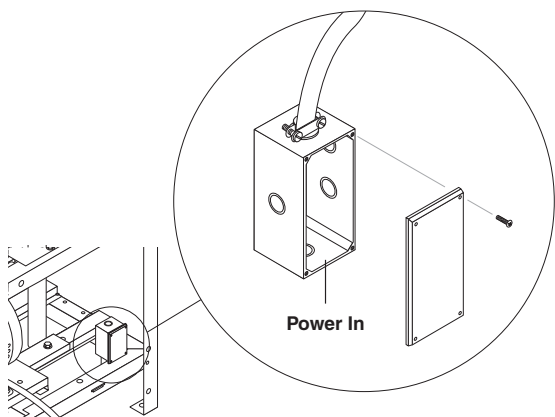

This machine is designed for connection to an overload protected grounded circuit. It is recommended this circuit be protected by a UL approved ground fault circuit interrupter (GFCI). An electrical disconnect must be provided in this circuit. All wiring must be of proper voltage and amperage rating and conform to applicable codes. A hole has been provided in the control box for attachment of 1 inch electrical conduit.

For proper operation the motor rotation is to be counter-clockwise as viewed looking towards the rear of the motor (opposite pump attachment). If the rotation is incorrect, interchange any two of the power supply connections to reverse rotation.

### Gas Burner

**CAUTION:** Have a qualified gas service technician modify, install and service your equipment.

**ATTENTION:** La modification, l'installation et l'entretien de l'équipement doivent être confiés à un technicien d'entretien qualifié dans le domaine du gaz.

**WARNING:** Gas line supply pressure must not exceed 14 water column inches (.50 PSI).

**AVERTISSEMENT:** La pression d'alimentation de la conduite d'alimentation en carburant ne doit pas excéder 14 pouces de colonne d'eau (.50 PSI).

**IMPORTANT:** Gas line must be provided with a shut off valve.

**IMPORTANT:** The gas supply must be able to supply a minimum of 525,000 BTU/HR at the machines rated manifold pressure.

Consult building codes for installation requirements. For proper and safe machine operation, we recommend that a licensed contractor be consulted for machine installation.

### Natural Gas Fuel

Have a qualified gas serviceman install the natural gas fuel supply line to the machine. See **below** for location of gas inlet.

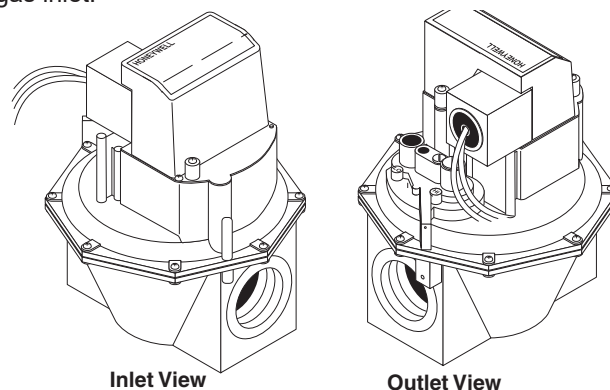

The ideal incoming gas pressure is 11 w.c.i. (water column inches) minimum 6 w.c.i., maximum 14 w.c.i. or 1/2 psig. The correct operating manifold pressure for natural gas is 3.5 w.c.i. The operating manifold pressure for propane gas is 11 w.c.i. The gas valve pressure regulator can be adjusted between 3 and 4 w.c.i. natural gas or 6 and 11 w.c.i. for propane.

The gas pressure coming out of the regulator and going to the burner ring has been factory set for elevations of 0 to 2000 ft. Altitudes greater than 2000 ft will require adjustments to the gas manifold pressures. Consult your local service dealer/distributor for high altitude adjustments. In Canada, certification for installation at altitudes over 4500 feet above sea level is the jurisdiction of local authorities. You should not readjust the burner ring gas pressure. If you replace your gas valve, you will need to adjust the new valve. Refer to your machine's **specification plate** for the correct pressure setting. Follow the installation and adjustment instructions provided with your replacement valve.

**NOTE:** Air for combustion and ventilation along with exhaust flue sizing must conform to methods outlined in current American Standard (ANSI-Z223.1) National Fuel Gas Code or National Standard of Canada CSA- 149.1 and CSA-149.2 "Installation Code for Gas Burning Appliances".

## Operations

### Gas Codes

Confer with local gas company and with proper municipal officials regarding any specific code or regulations governing the installation. The installation must conform to local codes (NFPA 54).

### Gas Piping

This machine shall be rigidly connected to the gas piping outlet and equipped with external manual shut-off valves adjacent to such machine. All gas piping shall be approved and installed in accordance with the Uniform Mechanical Code.

Install a gas union in the gas line adjacent to and upstream from the control manifold and downstream from the manual main shut-off valve. A 1/8" NPT plugged tapping accessible for test gauge connection shall be installed immediately upstream of the gas supply connection for the purpose of determining the gas supply pressure to the burner, and to prevent damage to gas valve.

If a manual gas shut off valve is not in the gas supply line within six feet of the machine and in an accessible location, one shall be installed.

### Union Location

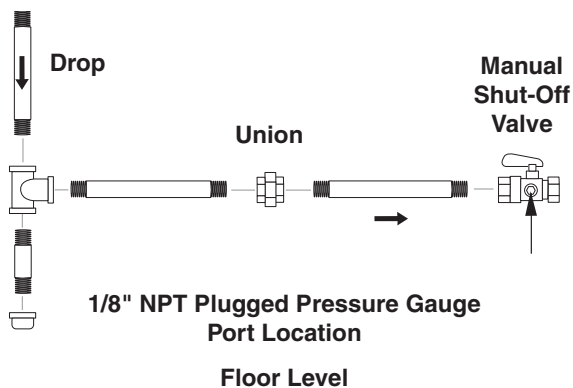

### Union Connection

The following pipe sizes are just recommendations. Always consult a local plumber and venting contractor for local codes and regulations during installation.

### Pipe Sizing Chart for Natural Gas

The following chart is based on gas pressure in the range 0-0.5 psi, specific gravity of 0.6 and pressure loss of 0.5" W.C. Numbers are for straight schedule 40 pipe; fittings further reduce capacity. For example, in 1" size, an elbow is equivalent to about 2.6 feet of pipe and a tee is equivalent to about 5.2 feet of pipe.

Maximum capacity of pipe in cubic feet/hr of natural gas (Multiply values by 1000 to get nominal BTU/hr capacity).

### LP-Gas (Liquid Petroleum Gas or Propane)

LP-gas is gas compressed into liquid form for easy transportation and storage. It is also known as propane or bottle gas. (Propane tanks are not supplied with this equipment.)

LP-gas is flammable, is always contained under pressure and the liquid can freeze skin. Therefore, in the interest of safety, it is important to understand the basic facts about LP-gas and LP-gas containers.

Federal DOT (Department of Transportation) regulations require periodic inspections and re-qualifications of cylinders. DO NOT USE damaged or rusted containers.

DO NOT store LP-gas containers indoors or in enclosed areas. Do not expose LP-gas container to heat. Always store with service valve closed and plugged as required.

**CAUTION: Use LP-gas containers in proper position.**

**ATTENTION: Utiliser des contenants de gaz de pétrole liquéfié en position appropriée.**

Most LP-gas pressure washer heaters are designed to operate on LP-gas vapor only. Therefore, all LP-gas containers designed for vapor service must be transported, installed and used in the proper position. Do not transport, install or use a vertical cylinder in a horizontal or upside down position. Proper care must be taken to position a horizontal container in the correct position for vapor withdrawal. Liquid LP-gas could enter the system designed for vapor only, possibly creating a hazardous condition.

Always use a POL plug installed on a POL valve or a dust cap on an ACME/Type 1 valve when transporting or storing disconnected containers (full or empty). Check for leaks after connecting. Apply approved leak detector solution to connection, turn off all burners and pilots and open service valve. Leaks will be detected by the growth of bubbles. If bubbles grow, tighten or repair the connection as needed. Repeat leak test until problem is corrected.

Check all tank and the line connections periodically to be sure they are tight. When testing for leaks, use approved leak detector solution — not matches.

**Improved Regulation:** The second stage regulator receives a relatively uniform pressure from the first stage regulator. This helps the second stage regulator to maintain appliance pressure at a nearly constant 11" W.C.

**Filling the LP-Gas Container**

*Only qualified persons should fill your LP-gas containers.*

Length of Pipe (ft.)	Iron Pipe Size				
	3/4"	1"	1 -1/4"	1- 1/2"	2"
10	360	680	1400	2100	3950
20	250	465	950	1460	2750
30	200	375	770	1180	2200
40	170	320	660	990	1900
50	151	285	580	900	1680
60	138	260	530	810	1520
70	125	240	490	750	1400
80	118	220	460	690	1300
90	110	205	430	650	1220
100	103	195	400	620	1150
150	84	160	325	500	950
200	72	135	280	430	800

**CAUTION: Overfilling is hazardous!**

**ATTENTION: Le remplissage excessif est dangereux.**

DO NOT allow your LP-gas container to be overfilled. Stop filling when liquid appears at the fixed level gauge. Bleed off excess propane in a safe area. Most LP-gas containers are equipped with a fixed liquid level gauge which contacts the liquid level at 80% of container capacity, allowing 20% for expansion. LP-gas containers not equipped with a fixed liquid level gauge can only be filled by weight.

In cold climates, in order to keep vaporization of LP-gas at the highest level, keep the fuel levels above 50%.

**Propane Tank Disposal**

Propane tanks present a real danger in the waste stream, so it is essential to properly dispose of old tanks so they do not injure you or sanitation workers. The best way to dispose of unused propane tanks is by calling a propane company to pick it up. Propane tanks are not picked up by garbage collectors, and improper

disposal is illegal in some areas. If a propane tank is unfit for service, one should contact a propane company.

**Venting**

**DANGER: DO NOT run machine indoors or in an enclosed area without proper ventilation, as exhaust fumes may be hazardous to your health.**

**DANGER: NE PAS faire fonctionner la machine à l'intérieur ou dans un endroit fermé sans une ventilation appropriée, car les gaz d'échappement pourraient comporter des dangers pour la santé.**

**DANGER: DO NOT operate machine in areas where flammable vapors (gasoline, solvents, etc.) may be present, as this machine may ignite the vapors.**

**DANGER: NE PAS utiliser la machine dans des endroits où des vapeurs inflammables (essence, solvants, etc.) pourraient être présentes, car cette machine pourrait enflammer les vapeurs**

**CAUTION: All venting must be in accordance with applicable federal and state laws, and local ordinances. This machine is not to be connected to a type B gas vent. Consult local heating contractors.**

**ATTENTION: Toute la ventilation doit être conforme aux lois fédérales et de l'État ou de la province, et aux réglementations locales applicables. Cette machine ne doit pas être raccordée à un évent de gaz de type B. Consulter les entrepreneurs de chauffage locaux.**

If the pressure washer is to be used in an enclosed area, a flue must be installed to vent burner exhaust to the outside atmosphere. Be sure the flue is the same size as the burner exhaust vent on the pressure washer lid. Poor draft will cause the pressure washer to soot and not operate properly. When selecting the location for installation, beware of poorly ventilated locations or areas where exhaust fans may cause an insufficient supply of oxygen. Proper combustion can only be obtained when there is a sufficient supply of oxygen available for the amount of fuel being burned. If it is necessary to install the machine in a poorly ventilated area, outside fresh air may have to be piped to the burner and a fan installed to bring sufficient air into the machine. Locate the pressure washer so that the flue will be as straight as possible and protrude through the roof at a proper height and location to provide adequate draft.

Hotsy natural and LP gas series pressure washers that incorporate a natural draft burner assembly designed to heat water that comes from the pressure washer pump require a draft diverter and vent pipe for exhausting to the outside. This operator's manual indicates this machine is to be vented through the ceiling using straight pipe or 45° elbows. It also discourages the use of any 90° venting elbows which restrict air flow through the burner causing

## Operations

poor burner conditions. If this machine is going to be installed to a 90° or extended exhaust vent run length which may restrict air flow it is recommended that a contractor install a power vent. When a contractor has found it impossible to vent through the ceiling then power venting can be calculated to help eliminate exhaust restriction on this natural draft machine. This draft inducer (power vent) must be installed by a licensed contractor who can calculate size, operation connections and associated dampeners. Hotsy is not a licensed contractor and as such we are unable to make recommendations for suitable make and model of power vents.

It is important that the licensed contractor consult local building codes. Hotsy can only make recommendations and the selection of the venting must take into account the type of roof or wall material it contacts which could change the vent requirement for compliance with local building codes

### Room Vents for Combustion and Ventilation Air

Properly sized vents are vital for the safe and efficient operation of a pressure washer installed in a confined space. When combustion and ventilation air are supplied from inside the building, each opening must have an area of one square inch for every 1,000 BTUH input. When combustion air is supplied from the outside, each opening must have an area of one square inch for every 2,000 BTUH for horizontal ducts and one square inch for every 4,000 BTUH for vertical ducts (refer to NFPA 54).

*NOTE: Air vents for combustion and ventilation and exhaust flue sizing must conform to methods outlined in current American Standard (ANSI-Z223.1), National Fuel Gas Code of National Standard of Canada CSA-149.1 and CSA-149.2 "Installation Code for Gas Burner Appliances".*

### Exhaust Stack

The purpose of venting a gas-fired pressure washer is to completely remove all products of combustion and to vent gasses to the outside air without condensation in the vent or spillage at the draft hood (except in cases of downdraft or poor stack conditions). Always use strong, gas-tight, insulated pipe.

The design of this pressure washer depends on natural draft (heat induced) to pull combustion gas out of the combustion chamber. The design of the exhaust stack can have a significant impact on the proper operation of the burner and coil.

During vent installation, avoid sharp turns, long horizontal runs and improper pitches. Maintain proper support of vent connectors and joints, observe clearances from all combustibles and top the vent outlet with an approved cap.

All venting installations must conform to local codes. In the absence of local codes, refer to "National Fuel Gas Code" NFPA 54 and be constructed of materials approved by the Uniform Building Code.

Vents penetrating ceilings or walls should be double-wall approved appliance vents and should be one to two inches from combustibles. Vents passing through enclosed spaces and vents exposed to the weather should also be the double-wall type. Sometimes vents have to be built of such great length that they come apart at their joints under their own weight. These should be screwed together at the joints with sheet metal screws, usually three per joint. If the inspector indicates that the vent is too close to combustibles, it may be necessary to chisel away some of the combustible or route the vent pipe around the combustible. The cross-sectional area of any flue shall not be less than the cross-sectional area of the flue vent connection outlet of machine.

### Ventilation

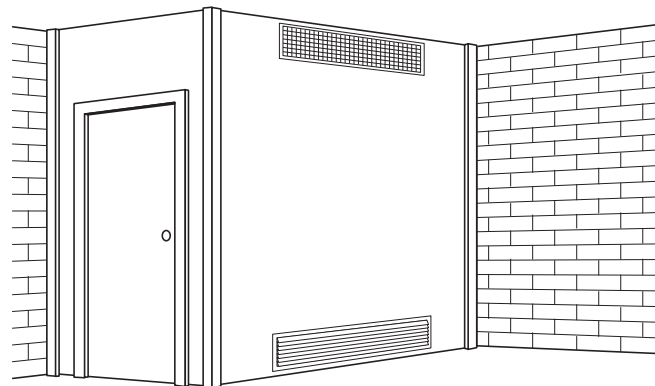
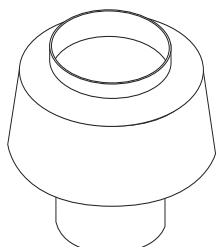

**Illustration showing air openings necessary to supply air for combustion when installed in an enclosed room.**

The pressure washer includes a collar that will mate with standard HVAC ducting. The user will be responsible for installation of an exhaust stack. The exhaust stack should include a Draft Diverter/Inducer, Damper, Sampling Port and Rain Cap. An adapter can be installed between the collar and stack to adjust the diameter from 10" to 8" or 12" to 10".

Size the stack according to the following (see also applicable local and national standards regarding installation of gas-fired appliances):

- 3.5 to 4.4 gpm      10" Collar      8" Stack
- 4.5 to 5.5 gpm      10" Collar      10" Stack
- 6.3 gpm              12" Collar      10" Stack
- 8 – 10 gpm          12" Collar      12" Stack



**Draft Diverter  
Required**

<b>8.717-728.0</b>	<b>8"</b>
<b>9.801-040.0</b>	<b>10"</b>
<b>8.717-730.0</b>	<b>12"</b>

**Draft Diverter/Hood** The draft required to vent combustion gases is created by the heat inside the pressure washer coil. A draft diverter helps improve draft into the stack without pulling more air through the combustion box and decreasing combustion efficiency. The draft diverter can also help prevent back drafting that can inhibit combustion. See page 8 for recommended installation instructions.

**Power Vent (Draft Inducer)** If this machine is going to be installed on a 90° or extended exhaust vent run length which may restrict air flow it is recommended that a contractor install a power vent. When a contractor has found it impossible to vent straight through the roof power venting is recommended to help eliminate exhaust restriction of this natural draft machine. This draft inducer (power vent) must be installed by a licensed contractor who can calculate size, operation connections and associated dampeners. Since we are a manufacturer and not a licensed contractor and as such we are unable to make recommendations for suitable make and model of power vents and compliance with local building codes.

**Damper** An exhaust stack can reduce thermal efficiency by drawing in too much combustion air. This can be controlled by adding a damper just below the draft diverter. 8.753-473.0 - 8" Damper, 8.753-474.0 -10" Damper, 8.753-418.0 - 12" Damper.

*NOTE: Closing the damper can create high levels of CO in the exhaust. Adjustments to the damper should only be performed by a trained technician using a flue gas analyzer. If an analyzer is not used the damper should be set in the fully open position.*

**Sampling Port** A port for sampling flue gases and measuring the flue gas temperature should be placed 18" above the flue collar. The port should be covered

when sampling is not being performed. The size of the port should be only slightly larger than the probe for the flue gas analyzer.

**Rain Cap** A rain cap should be installed on top of the stack to prevent rain water, leaves and debris from entering the stack. Your installer may also recommend specialty caps for high wind areas or cold weather zones to help prevent back drafting. 8.717-731.0 - 10" Raincap, 8.717-732.0 - 12" Raincap

**Water Source**

The water source for the machine should be supplied by a 5/8" I.D. garden hose with a city water pressure of not less than 30 PSI. If the water supply is inadequate, or if the garden hose is kinked, the machine will run very rough and the burner will not fire.

**Water Connection**

Connect the high pressure hose by pulling the coupler collar back and then inserting it onto the discharge nipple. Secure it by pushing the collar forward.

Attach the wand into the spray gun using teflon tape on the pipe threads to avoid leaks.

**Inspection and Testing Gas Piping**

The building structure should not be weakened by installing the gas piping. The piping should not be supported by other piping, but should be firmly supported with gas hooks, straps, bands or hangers. Butt or lap welded pipe should not be run through or in an air duct or clothes chute.

Before turning gas under pressure into piping, all openings from which gas can escape should be closed. Immediately after turning on gas, the system should be checked for leaks. This can be done by watching the 1/2 cubic foot test dial for 5 minutes for any movement or by soaping each pipe connection and watching for bubbles. If a leak is found, make the necessary repairs and repeat the above test.

Defective pipes or fittings should be replaced and not repaired. Never use a flame or fire in any form to locate gas leaks — use a soap solution.

After the piping and meter have been checked completely, purge the system of air. **DO NOT** bleed the air inside an enclosed room.

During pressure testing of the system at test pressures in excess of 1/2 PSIG, the pressure washer and its individual shut-off valve must be disconnected from gas supply piping system or damage to the gas valve will occur.

## Operations

### Gas Pressure

The incoming gas pressure must be a minimum of 9.0 wc-in and must not exceed 13.8 wc-in or ½ psig to the control valve. Line pressure above ½ psig must be regulated prior to the machine. The ideal supply pressure is 13.0-13.5 wc-in. If the required BTU input can not be achieved consult the factory for instructions regarding changes to the nozzle orifice size and an appropriate manifold setting.

*NOTE: Any changes to the burner and manifold pressure setting should only be performed by a trained technician and adjusted using a flue gas analyzer.*

*The manifold pressure has been preset at the factory according to the table below for optimum operation at sea-level. The manifold pressure and BTU input will be listed on the specification plate for the machine.*

### For Tech Tip Instructions

Combustion efficiency in a natural draft pressure washer is significantly influenced by the heat created inside the coil, the design of the coil and flue and the length and diameter of the exhaust stack. The table below shows data included in the operator's manual for flue and stack sizes and gas manifold pressure settings. These sizes are critical for achieving proper combustion and acceptable emissions.

Testing has shown that simply adding a 36" stack extension to the flue adapter on top of the pressure washer can reduce the outlet temperature by 5-10°F.

Model	Collar	Stack	NG		LP	
			wc-in	kBTU-in	wc-in	kBTU-in
3.5@2000	10"	8"	3.6	310	7.8	310
3.9@3000	10"	8"	3.4	354	7.4	354
4@2200	10"	8"	5.1	364	11.2	364
4.8@3000	10"	10"	4.2	415	9.1	415
5.0@2300	10"	10"	4.7	437	9.5	439
6.3@3200	12"	10"	4.3	507	7.4	507
8@3200	12"	12"	3.1	658	7.0	658
9.5@3000	12"	12"	5.4	816	10.0	775

This occurs by inducing a higher pressure differential at the exit of the coil and increasing the flow of air into the combustion process and through the stack. Most or all of the lost outlet temperature can be recovered by installing and adjusting a damper in the stack. However this adjustment must only be performed by a trained

technician using a combustion analyzer. The analyzer must determine percent oxygen and/or percent excess air as a minimum.

The damper should be installed 24-36" above the flue adapter. The pressure washer can be operated safely with the damper fully open but with the lower outlet temperature. If the damper is closed too far there will not be enough oxygen to burn all of the fuel. This will cause higher and potentially dangerous levels of CO in the flue gas emissions.

To adjust the damper for proper combustion and efficiency perform the following:

1. If there is no sample port for the analyzer probe, drill a hole slightly larger than the combustion analyzer probe through the exhaust stack at a point about 18" above the flue adapter.
2. Insert the probe of the combustion analyzer so that the tip is at the center of the stack.
3. Open the damper to the fully open position.
4. Start the pressure washer and allow it to heat up for at least 20 minutes before making any adjustments.
5. Note the values for % Excess Air and/or % Oxygen.
6. Close the damper in small increments until % Excess Air is between 20-30% and/or % Oxygen is 4-5%.

This process can also be used when turning down the firing rate for high altitude installations above 2000 ft.

1. Adjust the gas pressure down 4% for every 1000 ft of elevation.

Example: Recommended firing rate for a 4.8@3000 is 4.2 wc-in. For an installation at 3500 feet reduce this pressure by 16% by setting the manifold pressure to  $4.2 \times .84 = 3.5$  wc-in.

A manometer capable of reading to at least the nearest 0.1 wc-in will be required for this adjustment.

2. Follow steps 1-6 above to optimize the outlet temperature of the pressure washer.

## Installations Above 2000 ft

Installation at altitudes greater than 2000 ft will require adjustments to the gas manifold pressure.

For installations above 2000 feet the firing rate should be reduced by 4% per 1000 feet. Example: Recommended firing rate for a 4.8@3000 is 4.2 wc-in. For an installation at 3500 feet reduce this pressure by 16% by setting the manifold pressure to  $4.2 \times .84 = 3.5$  wc-in. This adjustment should only be made by a properly trained service technician. A manometer capable of reading to the nearest 0.1 wc-in will be required for this adjustment.

In Canada, certification for installation at altitudes over 4500 feet is the jurisdiction of local authorities.

## Gas Valve Replacement

If you replace your gas valve the manifold pressure for the new valve will need to be adjusted to match the specification plate for the machine. Follow the installation and adjustment instructions provided with your replacement valve. A manometer capable of reading to the nearest 0.1 wc-in will be required for this adjustment.

**CAUTION: All gas conversion must be done by a qualified service person in accordance with these instructions and in compliance with all codes and requirements. In Canada, gas conversion shall be carried out in accordance with requirements of the Provincial Authorities having jurisdiction and in accordance with the requirements of the CAN/GGA-B149.1 and .2 installation code.**

**ATTENTION: Toutes les conversions au gaz doivent être effectuées par un technicien qualifié conformément à ces instructions et en conformité avec tous les codes et toutes les exigences. Au Canada, la conversion au gaz doit être effectuée conformément aux exigences des autorités provinciales compétentes et conformément aux exigences du code d'installation CAN/GGA-B149.1 et .2.**

## Operations

### Start-Up

**WARNING:** Read and follow instructions carefully when installing or servicing machine. Failure to do so may result in damage to property or personal injury.

**AVERTISSEMENT:** Lire attentivement les directives avant d'installer ou d'effectuer l'entretien de la machine. Le non-respect de cette consigne pourrait causer des dommages matériels ou des blessures corporelles.

1. Installation or servicing of gas appliances and controls must only be performed by qualified personnel. After installation or servicing, test the manual valve, operating valves, pressure regulation, and automatic shut-off valve for proper operation.
2. Install in a suitable dry location. Machine must be located in an area properly protected from weather.
3. Shut off gas and electricity before starting installation or service. Turn back on to test or operate.
4. **DO NOT** connect machine before pressure testing the gas piping. Damage to gas valve may result. (9" - 14" W.C.P. or 1/2 PSIG)
5. **DO NOT** insert any object other than suitable pipe or tubing in the inlet or outlet of the gas valve. Internal damage may occur and result in a hazardous condition.
6. **DO NOT** short the gas valve terminals.
7. **DO NOT** grip gas valve body with a pipe wrench or vise. Damage may result causing gas leakage. Use inlet or outlet bosses or a special body wrench.
8. **DO NOT** allow any flame to impinge on the regulator vent tubing if supplied. It may clog and cause gas valve malfunction.
9. **DO NOT** use the gas cock to adjust gas flow.
10. If main burner fails to shut off, turn off gas supply.
11. Keep all combustible materials away from gas appliances. **DO NOT** allow lint or dust to collect in burner area.
12. Dials must only be operated by hand. Never use pliers, wrenches or other tools to turn dials.
13. Leak test with a soap solution after installation or service with the main burner on. Coat pipe and tubing joints, gaskets, etc.

### FOR YOUR SAFETY READ BEFORE LIGHTING

#### WARNING

If you do not follow these instructions exactly, a fire or explosion may result, causing property damage, personal injury or loss of life.

A. This appliance has a pilot which must be lighted by hand. When lighting the pilot, follow these instructions exactly.

B. BEFORE LIGHTING smell all around the appliance area for gas. Be sure to smell next to the floor because some gas is heavier than air and will settle on the floor.

#### "FOR YOUR SAFETY "WHAT TO DO IF YOU SMELL GAS"

- Do not try to light any appliance.
- Do not touch any electrical switch, do not use any phone in your building.
- Immediately call your gas supplier from a neighbor's phone. Follow the gas supplier's instructions.
- If you cannot reach your supplier, call the fire dept.

C. Use only your hand to push in or turn the gas control knob. Never use tools. If the knob will not push in or turn by hand, don't try to repair it; call a qualified service technician. Forced or attempted repair may result in a fire or explosion.

D. Do not use this appliance if any part has been under water. Immediately call a qualified service technician to inspect the appliance and to replace any part of the control system and any gas control which has been under water.

**Check List Before Starting**

**CAUTION!** If “NO” has been checked on any of the following sixteen questions, do not operate this machine.

**ATTENTION:** Si la réponse à l'une des questions ci-dessus est « NON », ne pas utiliser la machine

	YES	NO
Has gas supply been inspected by an authorized contractor to meet local codes?		
Is machine protected from downdraft and excessive wind?		
Is machine shielded from moisture or water spray?		
Is the voltage correct and are the circuit breaker and supply cord adequate according to specifications and serial plate notation?		
Is the machine electrically grounded?		
Is there ample water supply?		
Have all flammable liquids or gases been removed from installation location?		
Is there adequate gas supply for the BTU rating of the burner?		
"Is incoming gas supply pressure between 6" - 14" water column inches or 1/2 PSIG?"		
Has the proper gas regulator been installed for pressure and volume?		
Have you installed the optional LP gas regulator assembly 9.802-633.0?		
Is the machine properly vented to allow adequate air flow?		
Are the propane tanks large enough, according to rating to prevent freezing?		
Have gas lines been checked for gas leaks?		
Have gas lines been checked with local codes?		
Have all operators using this machine been instructed properly and have they read the manual?		
Has the machine been installed according to operator's manual instructions?		

## Operations

### Operation Instructions

1. Read all manuals provided with this pressure washer. Become familiar with location and function of all operating and safety controls.

**WARNING:** Check hoses, fittings, wand, trigger gun and fuel connections daily for signs of wear, cracks and looseness, and replace as required.

**AVERTISSEMENT:** Vérifier les boyaux, les raccords, le pistolet à gâchette et les connexions de carburant pour la présence de traces d'usure, de fissures et de desserrement; remplacer au besoin.

2. Connect water supply hose to the garden hose connector located on the float tank. The water faucet and supply hose must be capable of providing a minimum of 8.0 gallons per minute (GPM).
3. If detergents are to be used, only use detergents intended for pressure washers. Follow instructions on the detergent container.

**IMPORTANT:** Before installing nozzle on initial start-up, turn on the water supply and pump switch and allow water to run from the end of the wand until clear to prevent the nozzle from clogging.

**IMPORTANT:** If the pressure washer has not been used for an extended period of time, remove the nozzle from the end of the wand and turn on water supply and pump switch. Allow water to run from the end of the wand until clear.

4. Install the proper pressure nozzle on end of wand for your cleaning needs.

**IMPORTANT:** The trigger gun provided with this pressure washer is equipped with a manual trigger lock to prevent accidental operation of the trigger gun. The trigger lock should be used whenever the trigger gun is not in use.

### To Start

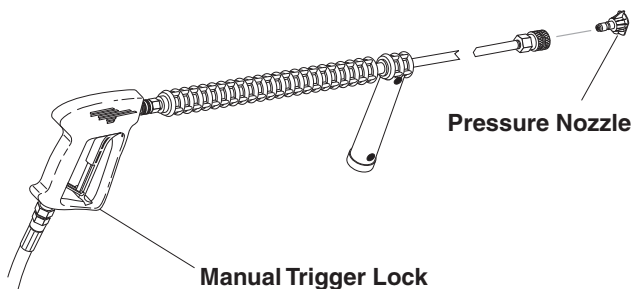

**DANGER:** DO NOT point wand or trigger gun at yourself or at any person or animal. Bodily injury may result from water under high pressure.

**DANGER:** NE PAS pointer la lance ou le pistolet pulvérisateur dans votre direction ou la direction d'une autre personne ou d'un animal. L'eau sous haute pression peut causer des lésions corporelles.

**WARNING:** Wear eye, ear, hand, foot and skin protection at all times while operating pressure washer.

**AVERTISSEMENT:** Porter une protection des yeux, des mains, des pieds et de la peau en tout temps en utilisant la laveuse à pression.

**IMPORTANT:** The water must be turned on before starting. Running the pump dry will cause damage and void warranty.

**IMPORTANT:** DO NOT allow the machine to run with trigger of the trigger gun released for more than 5 minutes at any one time or damage to pump may occur.

1. Turn ON water supply.
2. Hold wand firmly, release trigger of trigger gun and press pump start switch. Squeeze trigger of trigger gun and allow air to purge from system.
3. If HOT water is desired, adjust the thermostat to the proper temperature and turn burner switch ON. The burner will light immediately with a small puff of smoke. You may need to initially adjust your burner for peak performance. See **Burner** section under Installation. When the trigger of the trigger gun is released or when the thermostat temperature setting is reached, the burner will automatically turn off.

### To Stop

1. If detergents were used, draw clear water through the detergent inlet line to purge detergent. Failure to do so may clog detergent metering valve.
2. If burner was used, turn **OFF** burner switch and allow pump to run cold water through coil for several minutes.
3. Press pump **STOP** switch.
4. Turn water supply **OFF**.
5. Squeeze trigger of trigger gun to relieve system pressure.

## Cleaning Techniques

Pre-rinse cleaning surface with fresh water. Place detergent suction tube directly into cleaning solution and apply to surface at low pressure (for best results, limit your work area to sections approximately 6 feet square and always apply detergent from bottom to top). Allow detergent to remain on surface 1-3 minutes. Do not allow detergent to dry on surface. If surface appears to be drying, simply wet down surface with fresh water. If needed, use brush to remove stubborn dirt. Rinse at high pressure from top to bottom in an even sweeping motion keeping the spray nozzle approximately 1 foot from cleaning surface. Use overlapping strokes as you clean and rinse any surface. For best surface cleaning action spray at a slight angle.

### Recommendations:

- Before cleaning any surface, an inconspicuous area should be cleaned to test spray pattern and distance for maximum cleaning results.
- If painted surfaces are peeling or chipping, use extreme caution as pressure washer may remove the loose paint from the surface.
- Keep the spray nozzle a safe distance from the surface you plan to clean. High pressure wash a small area, then check the surface for damage. If no damage is found, continue to pressure washing.



#### **CAUTION - Never use:**

- Bleach, chlorine products and other corrosive chemicals
- Liquids containing solvents (i.e., paint thinner, gasoline, oils)
- Tri-sodium phosphate products
- Ammonia products or acid-based products



#### **ATTENTION: Ne jamais utiliser :**

- Eau de Javel, produits à base de chlore et autres produits chimiques corrosifs
- Liquides contenant des solvants (c.-à-d. diluant à peinture, essence, huiles, etc.)
- Produits à base de triphosphate de sodium
- Ammoniac ou produits à base d'acide

These chemicals will harm the machine and will damage the surface being cleaned.

## Rinsing

It will take a few seconds for the detergent to clear. Apply safety latch to spray gun. Select and install desired high pressure nozzle. **NOTE:** You can also stop detergent from flowing by removing detergent siphon tube from bottle.

## Storage

**DANGER: DO NOT store flammable liquids (gasoline, diesel fuel, solvents, etc.) near pressure washer, or in non-ventilated areas.**

**DANGER: Ne pas entreposer de liquides inflammables (essence, mazout, pétrole, solvants, etc.) à proximité de la laveuse à pression ou dans des endroits non ventilés.**

Protect from freezing by storing in a heated area, or by flushing the system with antifreeze (use an automotive engine antifreeze or windshield washer solvent to antifreeze). To flush the system fill the float tank with antifreeze and remove pressure nozzle from wand. Start the machine and allow it to run until antifreeze flows from the end of the wand. Place end of wand into float tank and circulate the antifreeze through system for several minutes. Squeeze and release the trigger of the trigger gun several times to antifreeze the unloader system. Also draw antifreeze through the detergent inlet line to antifreeze the detergent system. For added protection after antifreezing, disconnect the pressure hose from machine and remove the coil drain plug. After coil has drained, replace pressure hose and coil drain plug. If the pressure washer is not to be used for an extended length of time, it is recommended that the system be flushed with antifreeze for rust protection.

## Maintenance

**WARNING: Unauthorized machine modification or use of non-approved replacement parts may cause personal injury and/or property damage and will void the manufacturer warranty.**

**AVERTISSEMENT: Une modification non autorisée de la machine ou l'utilisation de pièces de rechange non approuvées peut causer des lésions corporelles et/ou des dommages à la propriété, et annulera la garantie du fabricant.**

## Maintenance

### Pump

**Lubrication:** To lubricate pump, use 10W-40 non-detergent oil for pump crankcase. Crankcase must be filled to center of sight glass window found on the rear of the pump. During the break-in-period, make sure the oil is changed after the first 25 hours of operation. After that, replace oil every 3 months or 300 hours of operation, whichever comes first.

#### Proper Pump Care:

- **DO NOT** pump acids.
- **DO NOT** allow pump to run dry.
- Winterize if storing in freezing temperatures, refer to **Storage** for details.
- Use a water softener on the water system if known to be high in mineral content.
- Use only high quality detergents and follow manufacturer's mix recommendations.
- Flush the system with clear water immediately after using detergent solutions.
- Clean filter screen on detergent inlet line periodically.

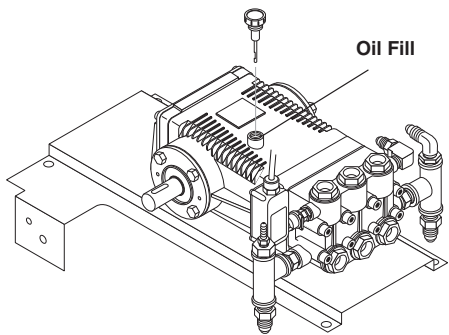

- Flush the pressure washer system with anti-freeze if storing for an extended period of time, refer to **Storage** to details.

### Pump Motor

Inspect the pump motor at regular intervals. The exterior of the motor should be kept free of dirt, oil, grease, water, etc. Keep all ventilation openings free from debris. If the motor is equipped with grease fittings, lubricate the motor after every 1000 hours of operation with Chevron SRI #2 lubricant or equivalent. If the motor is not equipped with grease fittings, the pump motor bearings are permanently lubricated and will not require any additional lubrication.

### Pressure Relief Valve

Each machine is equipped with a relief valve to relieve pressure in the system when higher than normal operating pressures are encountered or if the unloader valve should fail. Unusually high pressures come from an object plugging the spray nozzle. If operating pressure is found to be normal and the relief valve continues to leak, repair or replace valve. The Safety Relief Valve should be opened to release any sediment yearly. Start the pressure washer and use an Allen wrench to turn the pressure relief valve counter clockwise until water is pouring out the valve. Then turn the adjustment nut/bolt until the valve stops leaking. Open and close the trigger gun and if water squirts out the valve when you close the trigger gun turn clockwise one full turn until there is no leaking when the trigger gun is closed.

### Unloader Valve

**WARNING:** The unloader valve on this pressure washer has been factory set and sealed and is a field nonadjustable part. Tampering with the factory setting may cause personal injury and/or property damage, and will void the manufacturer warranty.

**AVERTISSEMENT:** La soupape de décompression sur cette laveuse à pression a été réglée en usine, puis scellée, et est une pièce non réglable. L'altération du paramètre de l'usine pourrait causer des lésions corporelles et/ou des dommages à la propriété, et annulera la garantie du fabricant.

### Heating Coil

**Coil Descaling:** In hard water areas, scale buildup within the heating coil will occur. Scale deposits will decrease the water temperature rise and may eventually clog the heating coil. Contact your local service center when descaling is needed.

**Coil Desooting:** Poor grades of fuel oil or inadequate combustion air will cause heavy soot buildup on the outside surface of the heating coil. These deposits will insulate the coil. This will restrict the air flow through the coil, further aggravating the soot buildup. Contact your local service center when desooting is needed.

**Troubleshooting**

<b>SYMPTOM</b>	<b>POSSIBLE CAUSES</b>	<b>CORRECTIVE ACTION</b>
<b>PRESSURE WASHER WILL NOT RUN</b>	Pump switch in OFF position	Place switch in ON position.
	Power supply disconnected	Connect power supply.
	Fuse blown or circuit breaker tripped in electrical supply line	Replace fuse or reset circuit breaker. Use only circuits of adequate capacity.
	Motor circuit overload tripped	Allow sufficient time for motor to cool down. Place pump switch in ON position.
<b>PRESSURE WASHER RUNS BUT WON'T SPRAY</b>	Trigger of trigger gun released	Squeeze trigger.
	Water supply not turned on	Open water supply valve.
	Clogged pressure nozzle	Clean pressure nozzle opening.
	Inlet water screen clogged	Check screen and clean if necessary.
	Pump sucking air	Fill the detergent container and check for loose hose clamps or fittings.
<b>LOW SPRAY PRESSURE AT NOZZLE</b>	Inadequate water supply	Fully open faucet. Check for kinked or damaged hose. Use 5/8" minimum hose. Check for debris clogging inlet screen."
	Partially clogged or damaged pressure nozzle	Clean or replace.
	Air being drawn through detergent inlet line	Refill detergent container. Ensure that pick-up screen is fully immersed.
<b>UNEVEN SPRAY PATTERN</b>	Partially clogged or damaged pressure nozzle	Clean or replace.
<b>PRESSURE WASHER WILL NOT PRODUCE HOT WATER</b>	Burner switch in OFF position	Place switch in ON position.
	Gas valve switch in OFF position	Place switch in ON position.
	Inadequate fuel supply	Check fuel supply.
	Pump switch turned off	Pump must be running before burner will light.
<b>BURNER SMOKES OR HAS OBNOXIOUS ODOR</b>	Stack restriction	See Venting under Installation.

## Maintenance

PROBLEM	POSSIBLE CAUSE	SOLUTION
<b>FLOW &amp; BURNER SWITCH ON; NO SPARK, NO PILOT GAS</b>	A. No main power	With power switch on, open trigger on spray gun and set your test meter to the 24 volt scale. Probe terminals 24V and 24V(GND). If you do not read 24 volts, the problem is not the ignition system. Perform normal system checks of main power, transformer, thermostat and the limit control. If you do read 24 volts at TH and GND, the problem is in the ignition system. Check for loose or defective wiring. If wiring is good, replace the ignition control unit.
	B. Faulty transformer	
	C. Faulty burner & flow switch	
	D. Faulty ignition control unit	
<b>HAVE SPARK, NO PILOT GAS FLOW</b>	Main gas supply turned off	Set test meter to 24 volt scale.
		1. Be sure main gas valve (gas cock or selector arm) is turned on.
		2. With gas on and system sparking, probe terminals PV and 24V(GND). If pilot gas does not flow with 24 volts at these terminals, replace gas valve.
		3. Probe terminals PV and MV/PV. If 24 volts not present, replace ignition control box.
<b>HAVE PILOT GAS, NO SPARK</b>	A. Defective ignitor/sensor and or its wiring	Set test meter to ohm scale.
		1. Disconnect the wire from the IGN terminal on the ignition control unit.
	B. Faulty ignition control unit	2. Touch one meter probe to the tip of the ignitor/sensor rod in the pilot. Touch the other probe to the quick connect at the other end of ignitor/sensor wire.
		3. If you have continuity from the tip of the ignitor/sensor rod to the connector and no spark, replace the ignition control unit.
		4. If you do not have continuity through wire and the ignitor/sensor, check for a loose wire connection in the wire. Repair as needed.
		5. Check to see if spark shorts to burner ring through a cut in the ignitor wire.

PROBLEM	POSSIBLE CAUSE	SOLUTION
<p><b>HAVE PILOT FLAME, MAIN BURNER WILL NOT TURN ON</b></p>	<p>Faulty main valve coil in the gas valve</p>	<p>Set test meter to 24 volt scale.</p>
	<p>Faulty ignitor/sensor and/or its wiring</p>	<p>With pilot flame on ignitor/sensor, probe terminals MV and MV/PV on the ignition control unit. If you read 24 volts here, but not at the gas valve, there is a loose wiring connection. Repair or replace as needed.</p>
	<p>Ground wire not attached to machine chassis</p>	<p>If you do read 24 volts at MV and MV/PV and the pilot flame is impinging on the ignitor/sensor rod, the problems may be:</p>
	<p>Faulty ignition control unit</p>	<p>a. Faulty ignitor/sensor and/or its wiring.</p>
		<p>b. Faulty ignition control unit.</p>
		<p>Set test meter to the ohm scale. Turn burner switch off.</p>
		<p>Check continuity through the green ground wire and its connections.</p>
<p>Reconnect the ignitor/sensor wire and the ground wire.</p>		
<p>Turn burner switch on. With the pilot burning and the flame on the ignitor/sensor rod, the main burner should turn on. If it does not, replace the ignition control unit.</p>		
<p><b>SHORT-CYCLING OF MAIN BURNER. MAIN BURNER TURNS OFF BEFORE THE BURNER SWITCH OR FLOW SWITCH IS TURNED OFF</b></p>	<p>Draft condition pulls flame from ignitor/sensor rod.</p>	<p>Check the thermostat by bypassing at terminals P1 &amp; 1.</p>
		<p>Set thermostat high. With main burner on, observe the pilot flame impingement on the ignitor/sensor.</p>
	<p>Faulty thermostat or water temperature is too high</p>	<p>If pilot flame is small and draft condition pulls flame from ignitor sensor rod, the burner will turn off and then on again. a. Adjust pilot flame higher or clean pilot orifice. b. Bend ignitor/sensor rod closer to pilot flame.</p>
		<p>If flame impingement on the ignitor/sensor is stable and the system short-cycles, check the limit switch.</p>
		<p>Set test meter to 110 volt scale; a. When the system cycles off, probe the switch terminals of the limit switch. b. If you read 24V across the switch terminals the limit switch is open. Replace the limit switch.</p>
<p>A pilot flame set too high will also cause burner to short cycle. Pilot flame lifts over ignitor/sensor.</p>		

If you need **SERVICE** on your pressure washer, contact your local Hotsy dealer or visit [www.Hotsy.com](http://www.Hotsy.com). Smart phone users scan the code below to link directly to the Service Request page.



To **REGISTER** your pressure washer, please visit our Warranty Registration page at [www.hotsy.com/WarrantyRegistration.aspx](http://www.hotsy.com/WarrantyRegistration.aspx) or scan the code below with your smart phone.

