

**WR-30E**

# **KÄRCHER**

## **Service Manual**

## **Water Reclamation System**

**MODEL: WR-30E**  
**1.103-516.0**

**FOR COMMERCIAL USE**

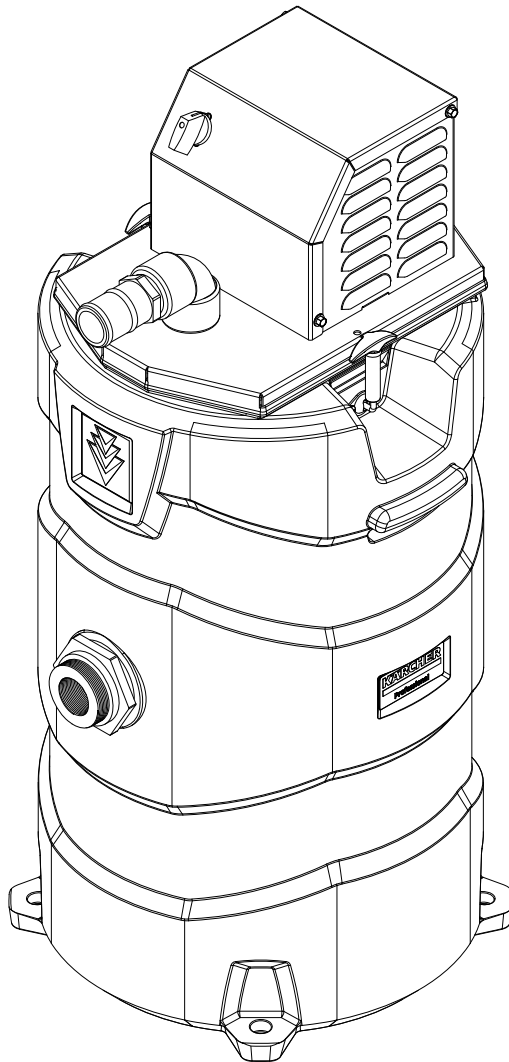

**For the Dealer nearest you,  
consult our web page at  
[www.karchercommercial.com](http://www.karchercommercial.com)**



9.808-123.0-D 05/01/19

## **Machine Data Label**

---

Model: \_\_\_\_\_

Date of Purchase: \_\_\_\_\_

Serial Number: \_\_\_\_\_

Dealer: \_\_\_\_\_

Address: \_\_\_\_\_

Phone Number: \_\_\_\_\_

Sales Representative: \_\_\_\_\_

Machine Data Label . . . . .	2
Table of Contents . . . . .	3
How To Use This Manual . . . . .	4

**Safety**

Important Safety Information . . . . .	5
Grounding Instructions . . . . .	6

**Operations**

Component Identification . . . . .	8
Installation & Start Up Instructions . . . . .	12
Installation . . . . .	12
Start Up . . . . .	12
Utility Usage . . . . .	12
Operating Environment . . . . .	13
Operating Conditions . . . . .	13
Cold Weather . . . . .	13
Cold Climate Conditions . . . . .	13
Sump Pump . . . . .	13
Pump Operation . . . . .	13
Environmental . . . . .	14
Maintenance Instructions . . . . .	14
Daily Schedule: . . . . .	14
Weekly Maintenance Schedule: (Performed by customer personnel) . . . . .	14
Pump Maintenance . . . . .	14
Troubleshooting . . . . .	15

**Parts**

Body . . . . .	18
Motor . . . . .	20
Sump Pump . . . . .	22
Ball Float . . . . .	24
Wiring Diagram . . . . .	26

## How To Use This Manual

This manual contains the following sections:

- How to Use This Manual
- Safety
- Operations
- Maintenance
- Parts List

The HOW TO USE THIS MANUAL section will tell you how to find important information for ordering correct repair parts.

Parts may be ordered from authorized dealers. When placing an order for parts, the machine model and machine serial number are important.

Model: _____
Date of Purchase: _____
Serial Number: _____
Dealer: _____
Address: _____
Phone Number: _____
Sales Representative: _____

The model and serial number of your machine are located on the back of the machine.

The SAFETY section contains important information regarding hazardous or unsafe practices of the machine. Levels of hazards are identified that could result in product damage, personal injury, or severe injury resulting in death.

The OPERATIONS section is to familiarize the operator with the operation and function of the machine.

The MAINTENANCE section contains preventive maintenance to keep the machine and its components in good working condition.

The PARTS LIST section contains assembled parts illustrations and corresponding parts list. The parts lists include a number of columns of information:

- **REF** – column refers to the reference number on the parts illustration.
- **PART NO.** – column lists the part number for the part.
- **QTY** – column lists the quantity of the part used in that area of the machine.
- **DESCRIPTION** – column is a brief description of the part.
- **NOTES** – column for information not noted by the other columns.

*NOTE: If a service or option kit is installed on your machine, be sure to keep the KIT INSTRUCTIONS which came with the kit. It contains replacement parts numbers needed for ordering future parts.*

*NOTE: The manual part number is located on the lower right corner of the front cover.*

## Important Safety Information

Your owner's manual has been prepared to provide you with a simple and understandable guide, for equipment operation and maintenance, based on the latest product information available at the time of printing. To keep your machine in top running condition follow the specific maintenance and troubleshooting procedures given in this manual.

**NOTE:** Kärcher reserves the right to make changes at any time without incurring any obligations.

## Owner/User Responsibility:

The owner and/or user must have an understanding of the manufacturer's operating instructions and warnings before using this equipment. Warning information should be emphasized and understood. If the operator is not fluent in English, the manufacturer's instructions and warnings shall be read to and discussed with the operator in the operator's native language by the purchaser/owner, making sure that the operator comprehends its contents.

Owner and/or user must study and maintain for future reference the manufacturers' instructions.

## Save These Instructions

This manual should be considered a permanent part of the machine and should remain with it if machine is resold.

When ordering parts, please specify model and serial number. Use only identical replacement parts.

This machine is to be used only by trained operators.

## General Safety Information



**WARNING:** When using this machine basic precautions should always be followed, including the following:

**AVERTISSEMENT:** En utilisant cette machine, des précautions de base devraient toujours être observées, y compris ce qui suit:

1. Read all the instructions before using the product.

2. To reduce the risk of injury, close supervision is necessary when a product is used near children.
3. Know how to stop the product. Be thoroughly familiar with the controls.
4. Stay alert – watch what you are doing.
5. Do not operate the product when fatigued or under the influence of alcohol or drugs.
6. Keep operating area clear of all persons.
7. Do not overreach or stand on unstable support.
8. Keep good footing and balance at all times. Follow the maintenance instructions specified in the manual.
9. Know the system application, limitations, and potential hazards.



**WARNING:** This machine must be wired to the correct voltage. Refer to the information located on the serial plate.

**AVERTISSEMENT:** Raccorder le système au réseau électrique en respectant la tension. Se référer aux informations qui se trouvent sur la plaque signalétique.

**WARNING:** All wiring must be performed by a qualified electrician.

**AVERTISSEMENT:** Tout le câblage doit être effectué par un électricien qualifié.

**WARNING:** Risk of Electric Shock

**AVERTISSEMENT:** Risque de choc électrique

## Safety

**DANGER:** Improper connection of the equipment grounding conductor can result in a risk of electrocution. Check with a qualified electrician or service personnel if you are in doubt as to whether the machine is properly grounded. All electrical lines must be installed by qualified personnel only. Do not use any type of adapter with this product.

**DANGER :** Une mauvaise connexion du conducteur de terre de l'équipement peut entraîner un risque d'électrocution. Vérifier auprès d'un électricien qualifié ou du personnel d'entretien si vous avez des doutes quant à savoir si la sortie est correctement mise à la masse. Toutes les lignes électriques doivent être installées par du personnel qualifié uniquement. **NE JAMAIS** utiliser un adaptateur avec ce produit.

### Grounding Instructions

This product must be connected to a grounded, metal, permanent wiring system; or an equipment-grounding conductor must be run with the circuit conductors and connected to the equipment-grounding terminal located on the product in compliance with National Electrical Codes (NEC).

**CAUTION:** Do not leave this product when plugged in. Unplug from outlet when not in use.

**ATTENTION :** Ne laissez pas ce produit lorsqu'il est branché. Débranchez la prise de courant lorsqu'elle n'est pas utilisée.

**CAUTION:** Do not unplug by pulling on cord. To unplug, grasp the plug, not the cord.

**ATTENTION :** Ne débranchez pas l'appareil en tirant sur le cordon. Pour le débrancher, empoignez la fiche, non pas le cordon.



**WARNING:** Do not use near concentrations of flammable or explosive fluids such as gasoline, fuel oil, kerosene, solvents, etc. Do not use in explosive atmospheres. Liquids compatible with component materials should only be used. Failure to follow this warning can result in personal injury and/or property damage.

**AVERTISSEMENT:** Ne pas utiliser près de concentrations de liquides inflammables ou explosifs tels que l'essence, le mazout, le kérosène, les solvants, etc. Ne pas utiliser dans des atmosphères explosives. Seuls des liquides compatibles aux matériaux des composants devraient être utilisés. Le non-respect de cet avertissement peut mener à des lésions corporelles et/ou des dommages à la propriété.

10. Protect all electrical cords from sharp objects, hot surfaces, oil, sunlight, and chemicals. Avoid kinking the cords.

**WARNING:** If any cords or electrical wires appear to be frayed, damaged, or in poor condition, proceed with caution and immediately take steps to have the cords repaired or replaced.

**AVERTISSEMENT:** Si un cordon ou des fils électriques semblent effilochés, endommagés ou en mauvais état, agir avec prudence et prendre immédiatement des mesures afin que les cordons soient réparés ou remplacés.

11. Never make adjustments on the machine while it is in operation, except for those prescribed in this manual.
12. Follow the maintenance instructions specified in this manual.
13. Before servicing the machine, refer to all the SDS's on the material identified in the waste stream. You must comply with all warnings and wear all protective clothing as stated on the SDS's.
14. The best insurance against an accident is precaution and knowledge of the equipment.
15. Kärcher is not liable for modifications or use of components not purchased from Kärcher.

16. Personal Safety:
  - a. Wear safety glasses and other applicable protective clothing at all times when working on this machine.
  - b. Keep your work area clean, uncluttered and properly lighted
  - c. Replace all unused tools and equipment.
  - d. Keep visitors at a safe distance from work area.
17. Release all pressure within the system before servicing any component.
18. Drain all liquids from the component before servicing.
19. Check hoses for weak or worn conditions before each use, making certain that all connections are secure.
20. Periodically inspect system components. Perform routine maintenance as required.
21. Do not touch an operating motor. Modern motors are designed to operate at high temperatures.
22. Do not touch any electrical component with wet hands, when standing on a wet or damp surface, or in water.
23. The pump motor is equipped with a thermal protector. Tripping is an indication of motor overloading as a result of operating at excessively high or low voltage, inadequate wiring or excessively high water temperature.
24. Do not spray water directly at machine.



**WARNING: Protect machine from freezing.**

**AVERTISSEMENT: Protéger la machine contre le gel.**

**WARNING: This system contains moving parts in the control box and in the pump. Follow safe practices when performing maintenance and when troubleshooting. Disconnect the power before servicing this machine.**

**AVERTISSEMENT: Ce système contient des pièces mobiles dans le centre de contrôle. Suivre les pratiques de sécurité au moment d'effectuer des opérations d'entretien et lors de la correction des erreurs. Débrancher l'alimentation avant d'effectuer des opérations d'entretien sur cette machine.**

**WARNING: Make sure to take precautions when performing maintenance on the pump in the catch basin. Turn off the power to the pump and make sure electrical cords are well maintained.**

**AVERTISSEMENT: S'assurer de prendre les précautions nécessaires au moment d'effectuer des opérations d'entretien sur la pompe dans le bassin collecteur. Mettre la pompe hors tension et s'assurer que les cordons électriques sont bien entretenus.**

# Operations

## Component Identification

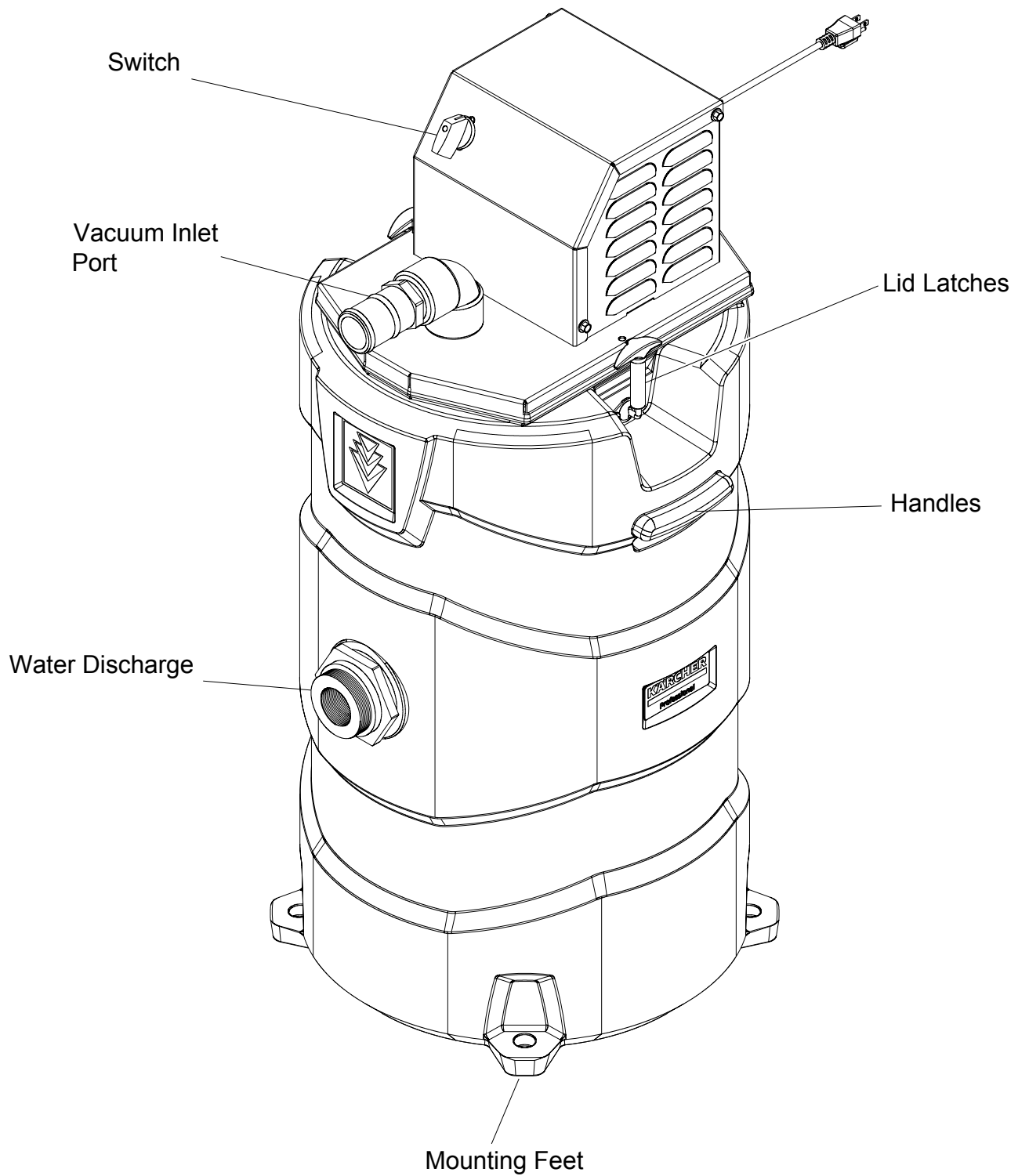



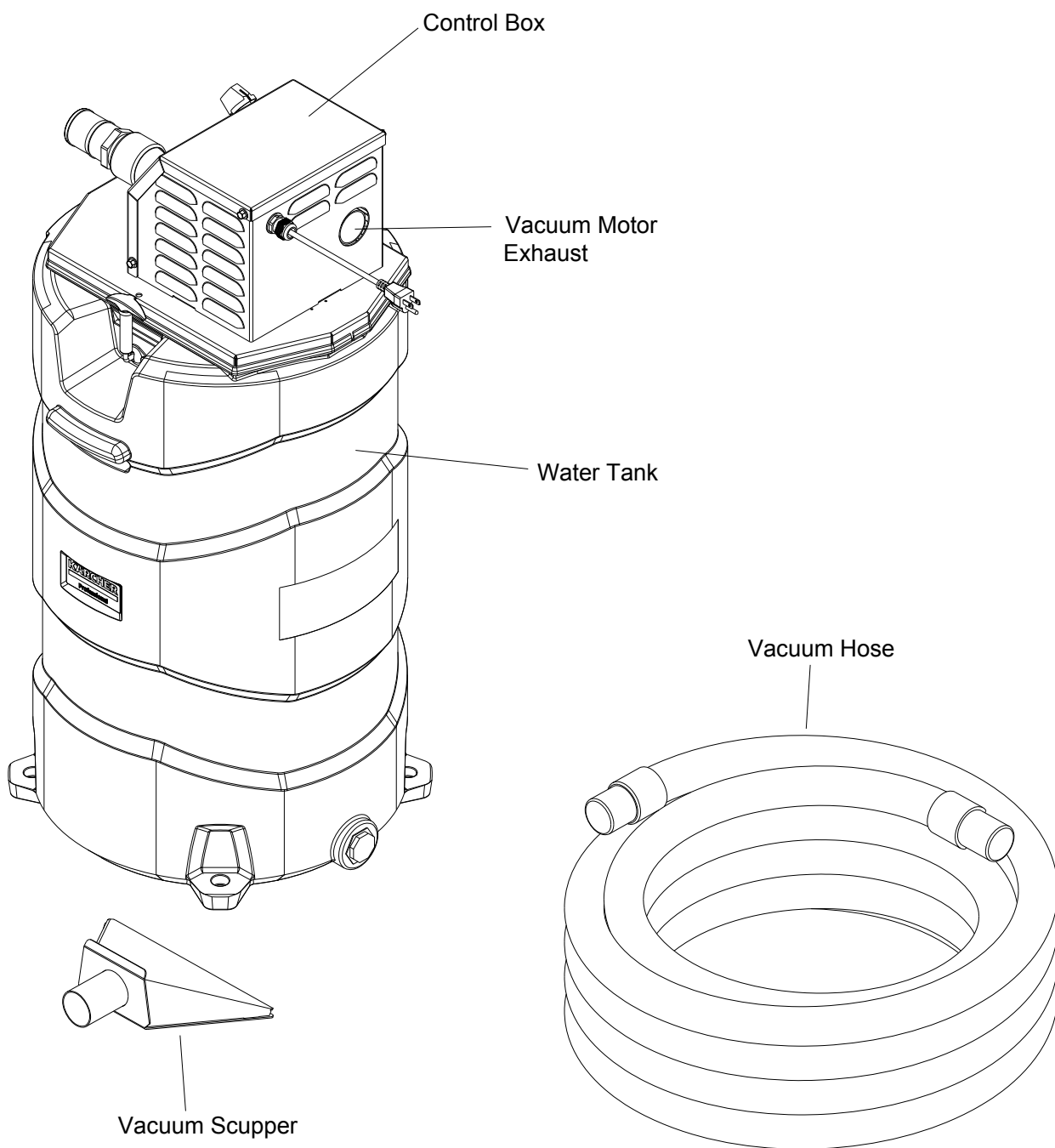

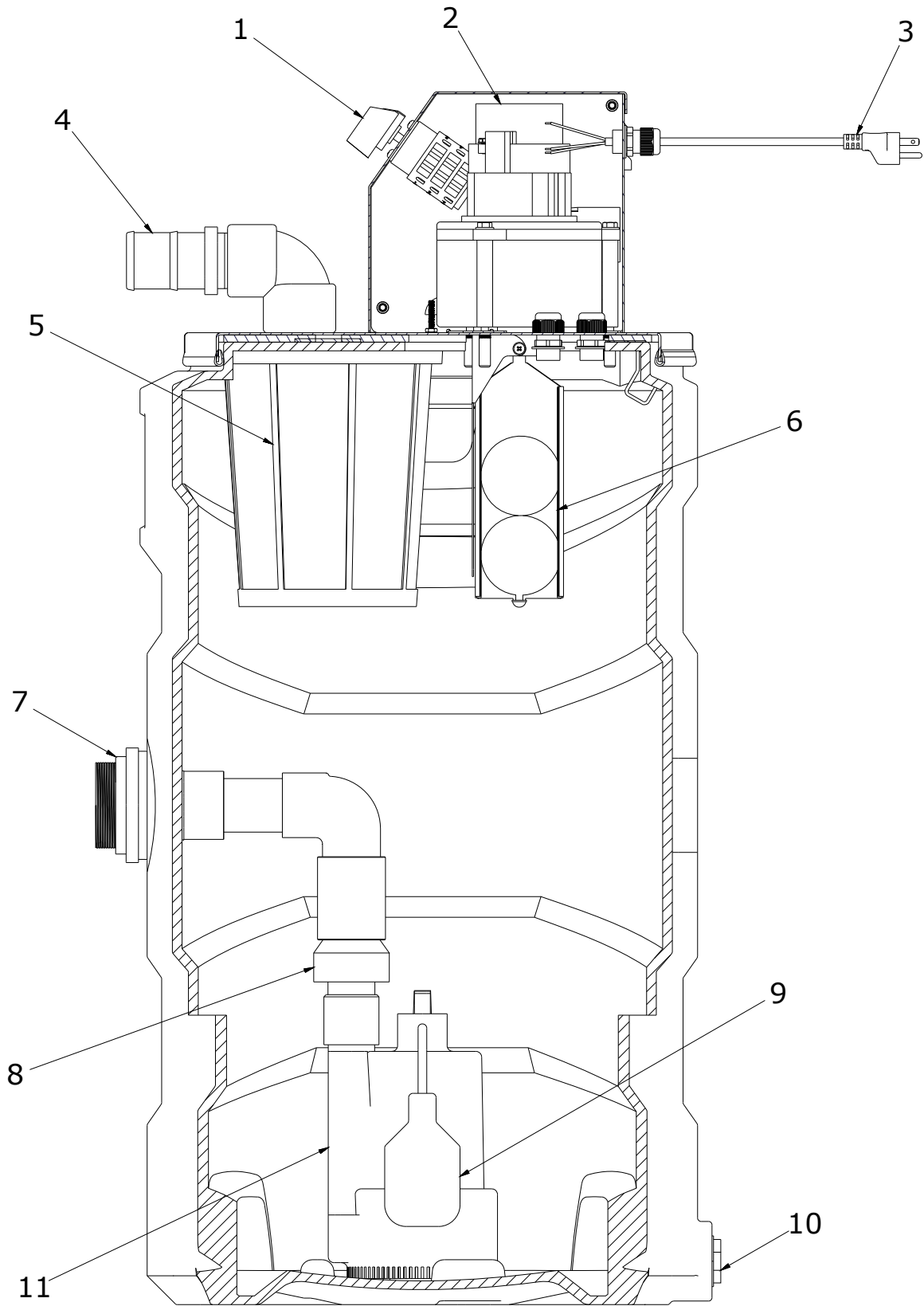

#	COMPONENT NAME	COMPONENT FUNCTION
1	Switch	Turning pump and vacuum motor ON/OFF.
2	Vacuum Motor	Reducing air pressure inside the tank to create suction.
3	Electrical Plug 120V	Supplying 120V/15A power to the system.
4	Suction Port	Connecting vacuum hose to the tank.
5	Screen Basket	Collecting light debris for waste water stream.
6	High Level Float Switch	Limiting water level, preventing water to get into the vacuum motor.
7	Discharge Port	Connecting transferring hose, discharging water.
8	Check Valve	Preventing vacuum losses due to air coming into the tank through the sump pump.
9	Low Level Float Switch	Preventing sump pump from running dry.
10	Tank Drain	Draining the tank.
11	Sump Pump	Transferring water to a holding tank or recycling system.

## Operations

### WR-30E Water Recovery Unit

The Kärcher WR-30E should be used as a waste water reclamation system, and a transferring unit to pump the waste water to a storage tank or to a water treatment system. Do not dump waste water on public sewer systems, make sure you understand local regulation before disposing waste water.

### Installation & Start Up Instructions

The following instructions will provide adequate information to fully install your Kärcher Recovery System. Please follow these instructions step by step to ensure proper installation.

#### Installation

The WR-30E is designed to be permanently installed on a flat level surface (e.g. trailers) and to be set up as a mobile unit to be used as a large wet/dry shop vacuum.

For a permanent installation on a flat level surface the following is required:

- A professional drill and a 3/8" drill bit.
- 3/8" bolts. (4)
- 3/8" vibration resistance nuts. (4)
- 3/8 flat washers. (8)
- Assembly tools.

Use one washer on the bolt head side and one on the nut side. Stainless Steel fasteners are recommended. Make sure to use the proper bolt length for your specific installation conditions.

For a mobile set up the casters KIT 8.928-887.0 will need to be ordered at your local Kärcher dealer, it will provide:

- Heavy duty casters (4)
- 3/8" x 3" stainless steel bolts (4)
- 3/8" stainless steel lock-nuts (4)
- 3/8" stainless steel flat washers (8)

Basic assembly tools will be required for installing the casters KIT

### Start Up

1. Connect the vacuum hose to the inlet port of the tank by pushing the hose end sleeve on the barbed couple.
2. Connect the opposite end of the vacuum hose to the stainless steel vacuum scupper provided with the unit.
3. Place the vacuum scupper at the point where the water will be pick up, usually this is a low point on the ground where water creates a puddle.
4. Connect the electrical plug provided with the WR-30E unit into a 120V/15AMP GFCI protected power supply.
5. Turn the vacuum motor switch to the "ON" position to start collecting water in the tank. As soon as the water level lifts the pump float switch the pump will be able to transfer water.
6. Turn the pump switch "ON" to evacuate the water or to transfer the water to a storage tank.
7. A hose and/or piping might be required to connect the discharge of the WR-30E unit to a storage tank. NEVER discharge waste water in the WR-30E tank into public sewer, make sure to comply with any applicable local regulation for waste eater disposal.

### Utility Usage

Electrical: 120 VAC, 1 PH  
Amps: 15 amps

## Operating Environment

The WR-30E is designed to work in a wide variety of operating conditions. In normal operating environments, the system should perform as specified. In extremely hot or cold environments certain precautions need to be taken.

## Operating Conditions

Air Temperature Range 40° - 120°F

## Cold Weather



Protect the WR-30E from damage that can occur when freezing water expands. Freezing water may cause hoses, pipes and tanks to burst.

Drain all water from the system if a prolonged hard freeze is expected.

## Cold Climate Conditions

In locations where freezing temperatures will be experienced on a regular basis or where very cold temperatures will be incurred, the water treatment system should be drained when the outside ambient temperature drops below freezing and/or the water recovery system (WR-30E) should be housed in a heated structure. The warranty on the water treatment system does not provide for repair due to freezing conditions.

## Sump Pump

Your Sump Pump is designed and built to give you reliable performance and long life. It will pump water automatically for years when properly used in the right environment

## Pump Operation



**WARNING:** Do not touch pump, pump motor, water or discharge piping when the pump is connected to electrical power. Do not handle a pump or pump motor with wet hands or when standing on a wet or damp surface or in water. Never touch a pump or discharge piping when a unit is operating or fails to operate. Always disconnect the pump cord (power) before handling.

**AVERTISSEMENT:** Ne pas toucher les pompes, les moteurs de pompe, les canalisations d'eau ou les tuyaux de refoulement lorsque les pompes sont connectées au réseau électrique. Ne pas manipuler une pompe ou un moteur de pompe avec les mains mouillées ou lorsque vous vous tenez sur une surface mouillée ou humide, ou encore dans l'eau. Ne jamais toucher une pompe ou la tuyauterie de sortie pendant qu'une machine est en marche ou ne fonctionne pas correctement. Toujours débrancher le cordon de la pompe (alimentation) avant la manutention

Your sump pump has thermal over-load protection built in. The thermal overload protector will automatically shut down the pump in an overheat situation. It will then reset itself once the pump cools down.

**CAUTION:** Do not run the pump without water or pump damage will result.

**ATTENTION:** Ne pas faire fonctionner la pompe sans eau pour éviter d'endommager la pompe.

The pump depends on water for cooling and lubrication. Operating the pump without water may cause the motor to overheat or cause damage to parts of the pump. It may also shorten the life of your pump.

## Maintenance

### Environmental

To reduce deterioration of equipment it is recommended that the RC-30E Water Recovery System be protected from environmental elements such as rain, snow, hail, direct sunlight, as well as freezing temperatures. For Outdoor use. Store indoors.

### Maintenance Instructions

Daily and weekly maintenance is important for your system to function consistently and properly. Maintenance frequency depends on many factors, such as usage, volume of sludge, etc. On-site personnel should be trained and be aware of the daily and weekly maintenance that is required to meet these performance factors. We recommend the following:

#### Daily Schedule:

##### (Performed by customer personnel)

1. Inspect the screen basket in the inlet of the tank, remove debris and rinse it as necessary,
2. A small amount of sludge might collect on the bottom of the tank, even after the pump evacuates all water from the tank, inspect and remove sludge as necessary using water and tank drain.
3. While operating the unit, observe and repair any water leaks.

#### Weekly Maintenance Schedule:

##### (Performed by customer personnel)

1. Inspect pump and vacuum motor for any function abnormalities, i.e.: noise changes, increase vibration, or rattling. Contact your local dealer for questions and replacement parts.

### Pump Maintenance

**WARNING: Before attempting to service, disconnect power from unit. Do not handle the pump with wet hands or when standing on a wet or damp surface or in water. Failure to follow precautions can result in personal injury and /or property damage.**

**AVERTISSEMENT: Toujours débrancher l'alimentation avant d'effectuer des opérations d'entretien sur la machine. Ne pas manipuler la pompe avec les mains mouillées ou lorsque vous vous tenez sur une surface mouillée ou humide, ou encore dans l'eau. Le non-respect des précautions peut mener à des lésions corporelles et/ou des dommages à la propriété.**

*NOTE: Only qualified electricians or servicemen should attempt to repair this unit. Improper repair and/ or assembly can cause an electrical shock hazard.*

1. Bearings in this unit are pre-lubricated. No additional lubrication is necessary.
2. Cleaning - Occasionally clean the bottom of the tank to remove sludge and silt, use a hose to agitate the sludge on the bottom with water and allow it to drain using the tank drain.

**Troubleshooting**

<b>PROBLEM</b>	<b>POSSIBLE CAUSES</b>	<b>SOLUTION</b>
<b>The Pump Does Not Start or Run</b>	Pump is not plugged in, switch or breaker is off.	Plug pump in or turn on switch/breaker.
	Check for blown fuses or tripped circuit breakers or tripped GFCI outlets.	Replace fuse, reset breaker, reset GFCI outlet.
	Float switch is defective.	Check and replace if necessary.
	Motor thermal protector tripped.	Allow pump to cool. Pump will reset.
	Float switch is stuck or obstructed.	Remove obstruction or position pump so it will not become stuck.
<b>The Pump Starts and Stops Too Often</b>	Backflow of water from discharge hose/pipe.	Install or replace check valve.
	Float switch is defective.	Replace float switch.
<b>The Pump Runs But Moves Little or No Water</b>	Clogged intake screen.	Clean or replace screen.
	Clogged discharge hose/pipe.	Remove clog.
	Frozen discharge hose/pipe.	Allow hose/pipe to thaw.
	Pump is air locked.	Clean out airlock hole with a paper clip or pipe cleaner.
	Low line voltage.	Check wire size and increase if necessary.
	Check valve is stuck in the closed position.	Inspect, repair or replace if necessary.
	Check valve is installed backwards.	Make sure check valve is installed in the correct direction of flow.
	Worn, damaged or clogged pump parts.	Inspect for wear, damage or clog and clean or replace if necessary.
Discharge head exceeds pump capacity.	If pumping height is over 25', the pump will not move water. See performance chart.	
<b>Pump Does Not Shut Off</b>	Float switch is obstructed or stuck.	Remove obstruction.
	Defective Float Switch.	Replace switch.
<b>Vacuum Motor Does Not Turn On</b>	Low voltage from power outlet.	Check for proper supply voltage to make certain it corresponds to nameplate voltage.
	GFCI opened the circuit	Reset the GFCI by pushing the reset button on the back of the plug, inspect the electrical outlet. If electrical outlet is equipped with a GFCI, make sure it is not open. Reset outlet if needed.
	Water level has reached the maximum level.	Transfer water to a storage tank or a recycle system. Drain the tank using the bottom drain, make sure to comply with local regulations for disposing waste water.

## Maintenance

PROBLEM	POSSIBLE CAUSE	SOLUTION
<b>Vacuum Motor Does Not Turn On</b>	High level float switch is stuck or obstructed.	Remove obstruction so it will not become stuck. Make sure the float switch hangs at the right cord length, adjust to the original length of 1.5" from the edge of the PVC pipe if necessary.
<b>Vacuum Motor Starts But Turns Off Quickly.</b>	Water level reaches the maximum level.	Transfer water to a storage tank or a recycle system.
		Drain the tank using the bottom drain, make sure to comply with local regulations for disposing waste water.
		If recovering a large amount of water, keep the transfer pump switch on the "ON" position so that it keeps water level low.
<b>Reduced Water Recovery Rate</b>	Screen basket is full of debris.	Remove screen basket from the top of the tank, remove debris and rinse. Install it back.
	Hose length.	This unit is designed to work with a 50' vacuum hose and it is not recommended to use longer hoses or extensions.
	Vacuum head clogged (scupper).	Inspect vacuum head for possible large debris clogging the openings.



# Parts

**Kärcher WR-30E**

**1.103-516.0**

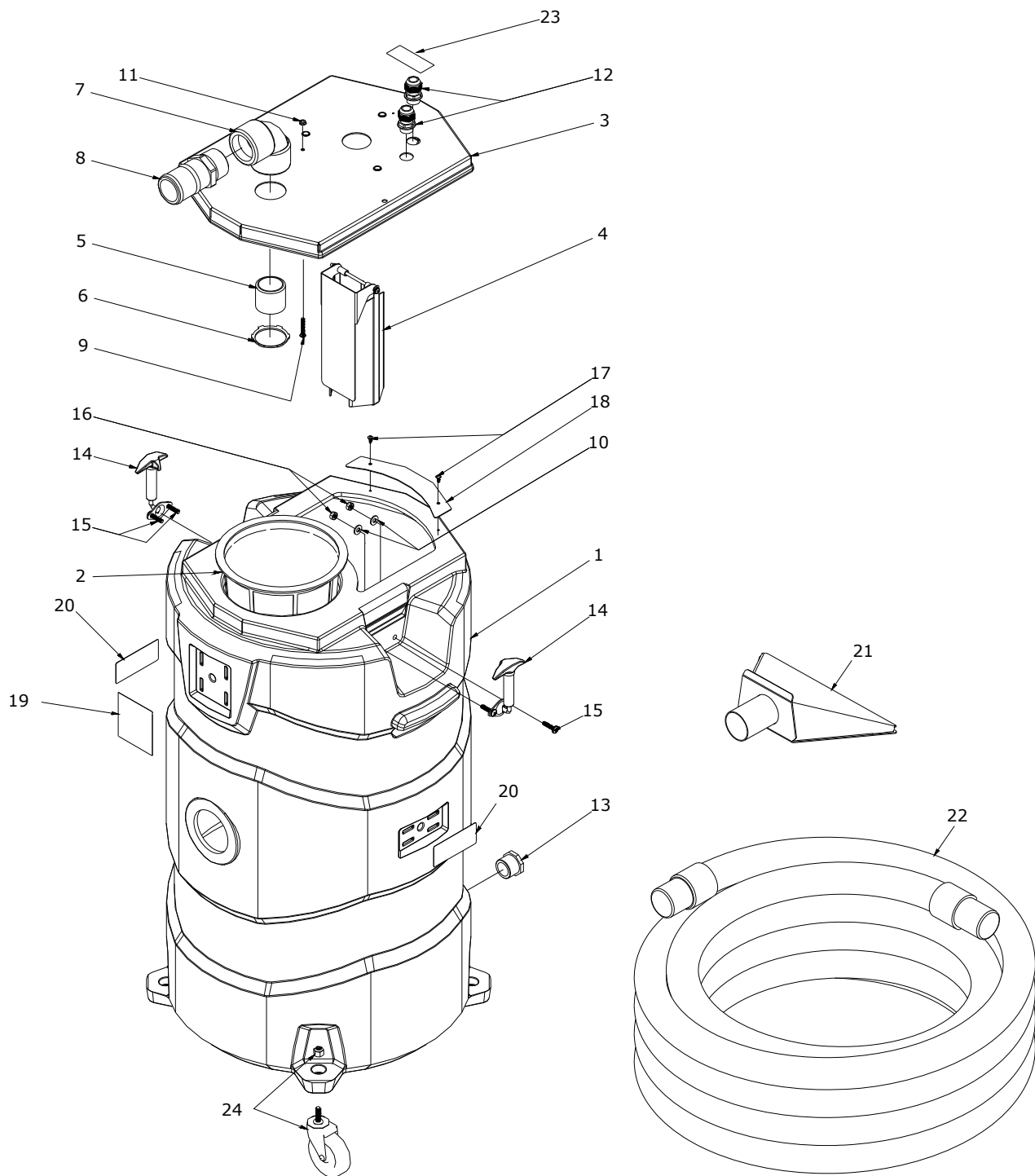

REF	PART NO.	QTY	DESCRIPTION	SERIAL NO. FROM	NOTES
1	8.757-376.0	1	RECOVERY WATER TANK 25 GALLONS HDPE		
2	8.757-375.0	1	SCREEN BASKET 7.5"		
3	8.928-859.0	1	LID RECOVERY TANK		
4	8.929-146.0	1	BALL FLOAT ASSEMBLY		
5	8.706-012.0	1	NIPPLE, 1-1/2" X CLOSE, 316L SS		
6	8.750-293.0	1	LOCKNUT 1.5" CONDUIT		
7	8.706-375.0	1	ELBOW, 1-1/2" FT X FT, PVC 80, 90 DGR		
8	8.757-501.0	1	ADAPTER 1-1/2" MPT X 2" HB GRPP BLK		
9	8.718-814.0	1	SCREW, 10-32 X 1-1/4 BH SOC, SS		
10	8.718-568.0	4	WASHER, 1/4" FLAT RUBBER BACK, SS		
11	9.802-696.0	1	NUT, 10/32" KEPS, SS		
12	9.802-514.0	2	STRAIN RELIEF, LT, STR, 1/2 NPT,.23-.45D		
13	8.725-518.0	1	PLUG, SCH 40, 1" PVC		
14	8.758-004.0	2	LATCH SPRING LOADED T-HANDLE 3.50		
15	8.718-747.0	4	SCREW, 1/4" X 1", PH PHIL, SS		
16	9.802-774.0	4	*NUT, 1/4", ESNA, NC, SS		
17	8.758-003.0	2	SCREW 8-16 X .375 PHPNHTF SS		
18	8.929-166.0	1	STRIKER PLATE RECOVERY UNIT		
19	4.385-004.0	1	LABEL KÄRCHER SIGNET 3" X 3.35"		
20	4.385-000.0	2	LABEL KÄRCHER LOGO L 3.75" X 1.6"		
21	8.928-850.0	1	VACUUM HEAD		
22	8.618-451.0	1	HOSE, 2" ID X 50' GRY VAC		
23	8.901-135.0	1	LABEL, CAUTION WINTERIZE		
24	8.928-887.0	1	CASTERS KIT RECOVERY UNIT		
-	8.757-899.0	2	CASTER WHEEL 3"		INCLUDED IN 24
-	8.757-900.0	2	CASTER WHEEL 3" WITH BRAKE		INCLUDED IN 24
-	9.802-780.0	4	NUT, 3/8" STAINLESS, ESNA, NC		INCLUDED IN 24
-	9.802-808.0	8	WASHER, 3/8" SAE, SS(936631)		INCLUDED IN 24

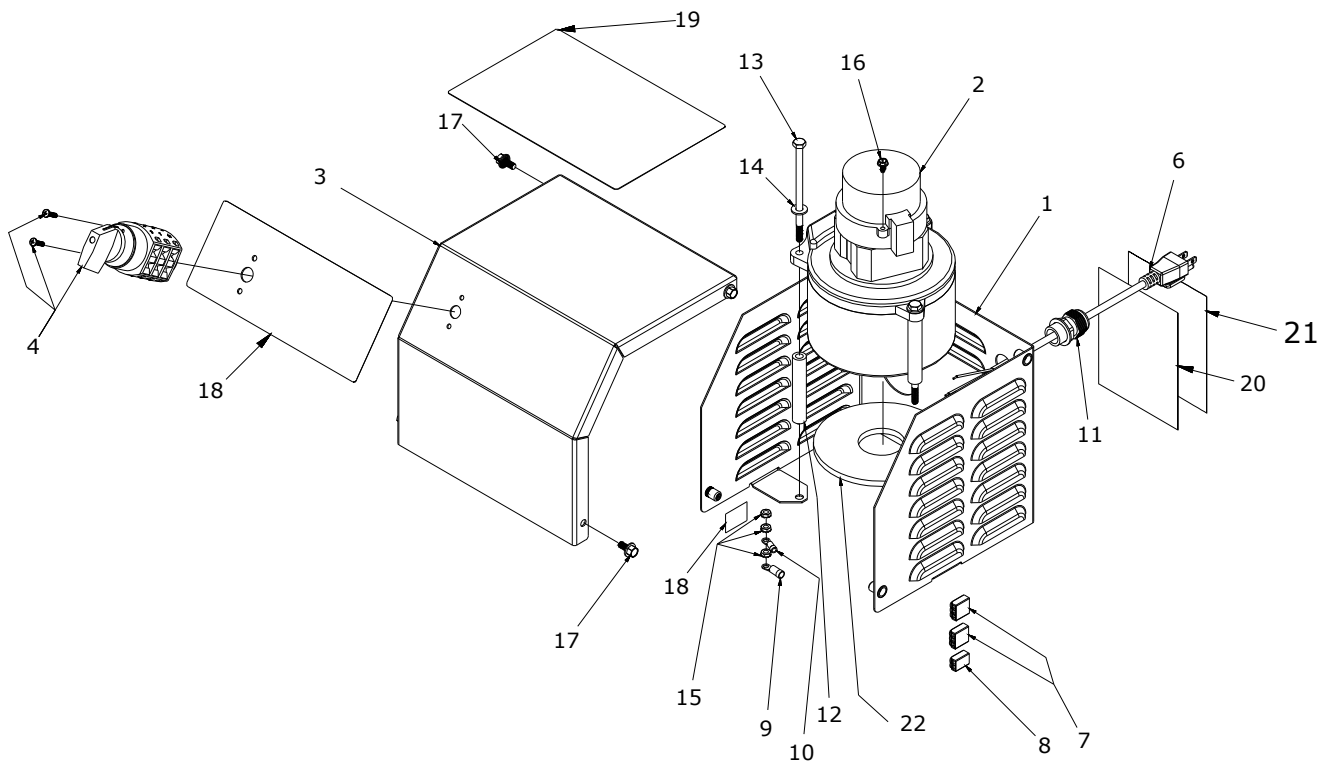

REF	PART NO.	QTY	DESCRIPTION	SERIAL NO. FROM	NOTES
1	8.928-792.0	1	BLOWER HOUSING		
2	8.925-861.0	1	VAC MOTOR 120V RECOVERY UNIT		
3	8.928-797.0	1	VACUUM MOTOR HOUSING COVER ROTARY SWITCH		
4	8.757-934.0	1	SWITCH ROTARY 4 POSITION		
5	8.757-983.0	1	ELECTRIC HARNESS KARCHER RECOVERY UNIT		NOT SHOWN
6	8.757-898.0	1	CORD SERVICE 12/3 X 15' SJOW 120V 15A		
7	8.756-410.0	2	CONNECTOR, LEVER NUT, 3-WIRES		
8	8.756-409.0	1	CONNECTOR, LEVER NUT, 2-WIRES		
9	8.716-376.0	1	TERMINAL, RING TONGUE, 10RC-10		
10	8.716-377.0	1	TERMINAL, RING TONGUE, 14AB-10		
11	9.802-514.0	1	STRAIN RELIEF, LT, STR, 1/2 NPT,.23-.45D		
12	8.928-848.0	3	SPACER 1/4" PIPE PVC SCH80		
13	8.751-242.0	3	BOLT, TAP, 1/4" X 4-1/2" A307A, ZN PLT		
14	9.804-082.0	3	WASHER, 1/4"X 0.625 X 0.65 STL BLK ZN PLT		
15	9.802-696.0	3	NUT, 10-32 KEPS SS		
16	8.757-679.0	1	SCREW 10-32 X .375 HEXTC ZNPLT		
17	8.751-836.0	4	SCREW, 1/4-20 X 1/2", WHIZ LOC FLANGE SS		
18	8.757-971.0	1	LABELS SHEET KARCHER RECOVERY		
19	8.757-554.0	1	WARNING LABEL RECOVERY UNIT		
20	8.932-968.0	1	LABEL, INTENDED FOR OUTDOOR USE - USA		
21	9.800-034.0	1	LABEL CLEAR LEXAN 4.30" X 4.70"		
22	8.757-372.0	1	LID SEAL NEOPRENE SC41W PSA		

# Sump Pump

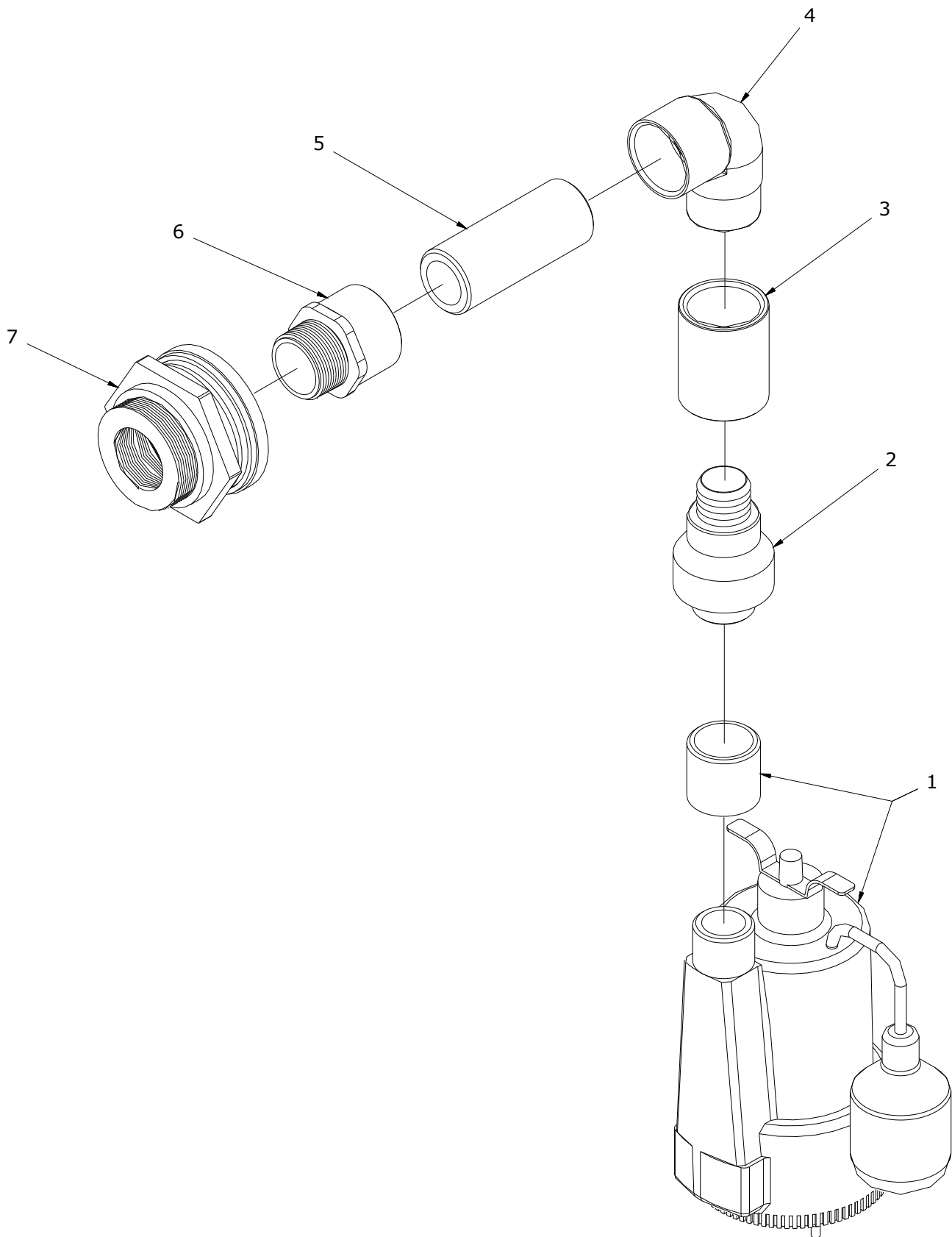

REF	PART NO.	QTY	DESCRIPTION	SERIAL NO. FROM	NOTES
1	8.757-380.0	1	SUMP PUMP 1/3HP FLOAT SWITCH		COUPLER INCLUDED WITH PUMP
2	8.757-381.0	1	CHECK VALVE 1-1/4"		
3	8.757-382.0	1	COUPLER 1 -1/2" SLIPXSLIP PVC SCH40		
4	8.757-383.0	1	ELBOW STREET 1-1/2" SOCKET X SPIGOT SCH40		
5	8.928-710.0	1	NIPPLE SCH80 4.6" 1-1/2" PVC		
6	8.757-545.0	1	ADAPTER 1.5" SLIP X MT, PVC SCH 40		
7	8.706-490.0	1	BULKHEAD, 1-1/2" POLYPRO		

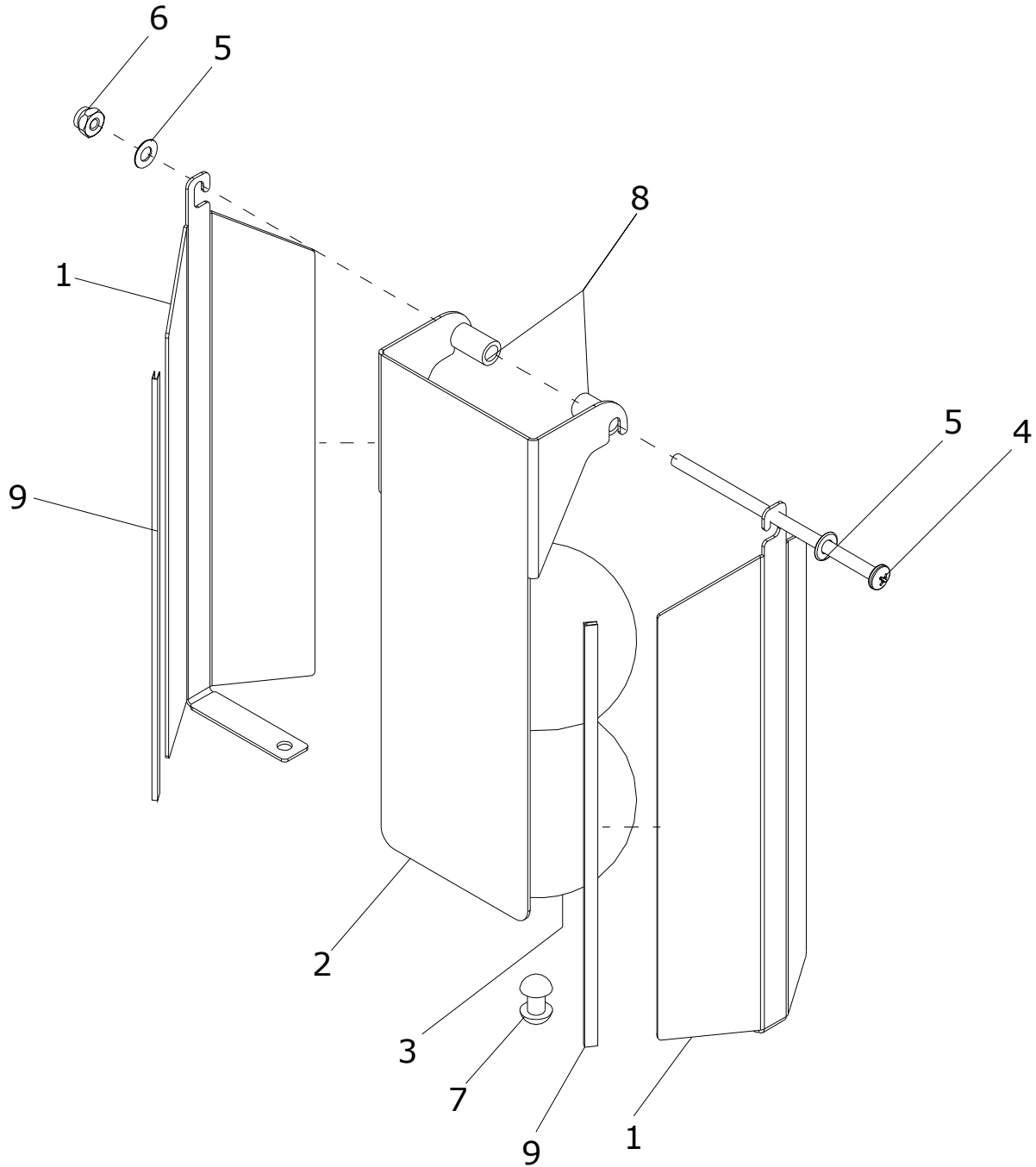



REF	PART NO.	QTY	DESCRIPTION	SERIAL NO. FROM	NOTES
1	8.929-112.0	1	CAGE FLOAT BALL		
2	8.929-113.0	1	SHIELD FLOAT BALL		
3	8.757-940.0	2	BALL FLOAT 2.75 DIAMETER		
4	8.757-941.0	1	SCREW 10-32 X 4" PAN HEAD SS		
5	8.718-959.0	2	WASHER, #10 FLAT S/S		
6	8.718-860.0	1	NUT, 10/32", ESNA, SS		
7	8.719-053.0	1	RIVET, 3/16 DIA .126-.250" GRIP, S/S		
8	8.925-857.0	2	SPACER TUBING 1/4" ID X 5/8" OPAQUE POLY		
9	8.929-149.0	2	EDGE TRIM NEOPRENE 7.25 L		

# Wiring Diagram

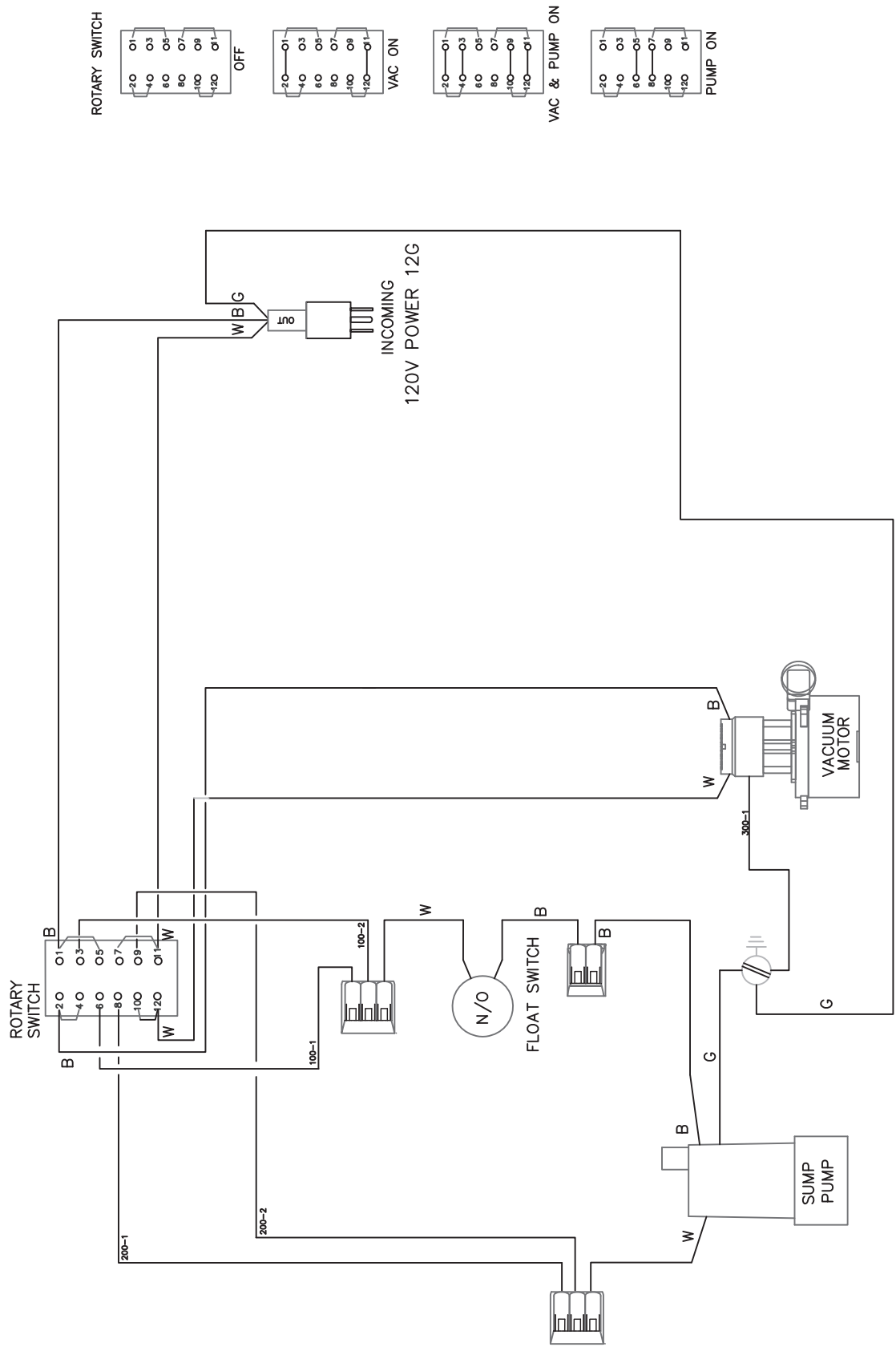



**KÄRCHER**



9.808-123.0 • Printed in U.S.A.