

**900 / 1400 Series
Hot Water - Gas Fired**

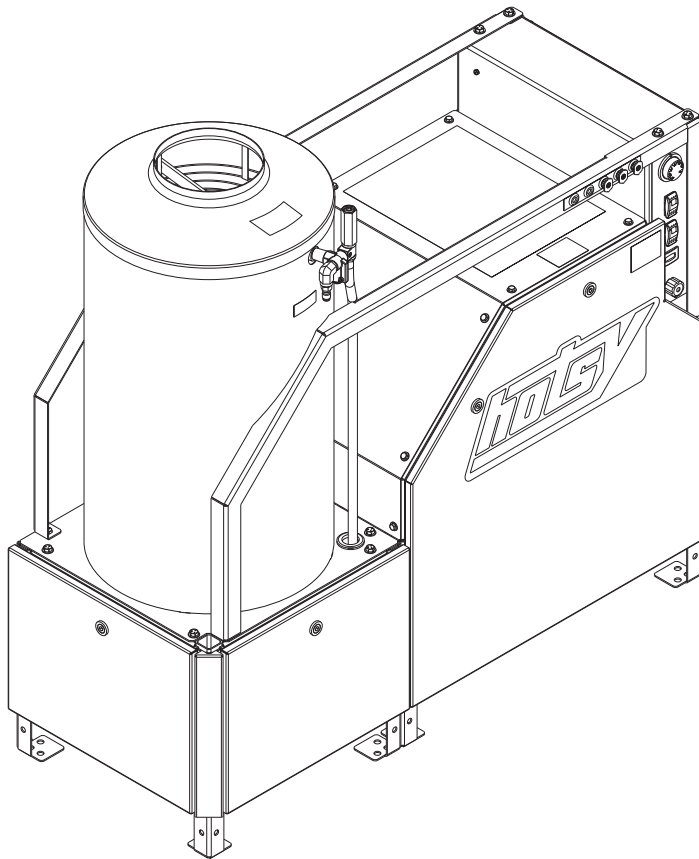

Operator's Manual

Pressure Washer



MODELS:

921P	1453P
1.109-184.0	1.109-200.0
921N	1453N
1.109-185.0	1.109-201.0
926P	1454P
1.109-186.0	1.109-202.0
926N	1454N
1.109-187.0	1.109-203.0
942P	1455P
1.109-188.0	1.109-204.0
942N	1455N
1.109-189.0	1.109-205.0
943P	1456P
1.109-190.0	1.109-206.0
943N	1456N
1.109-191.0	1.109-207.0
944P	1473P
1.109-192.0	1.109-208.0
944N	1473N
1.109-193.0	1.109-209.0
945P	1474P
1.109-194.0	1.109-210.0
945N	1474N
1.109-195.0	1.109-211.0
1451P	1475P
1.109-196.0	1.109-212.0
1451N	1475N
1.109-197.0	1.109-213.0
1452P	1476P
1.109-198.0	1.109-219.0
1452N	1476N
1.109-199.0	

Scan or Click to View
The Hotsy Safety Video



For the Hotsy Dealer nearest you,
consult our web page at
www.hotsy.com



Intertek



9.802-199.0 - D

10/11/24

MACHINE DATA LABEL

Model: _____

Date of Purchase: _____

Serial Number: _____

Dealer: _____

Address: _____

Phone Number: _____

Sales Representative: _____

Identification of Operational Label Symbols



Burner Switch



Pump Switch



Hour Meter



Steam Combination



Detergent

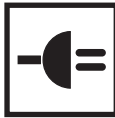

Voltage

When the light is on, it means power supply is on



Pilot Light

When the light is on, it means there is power to the pilot control.
If there is no light, see troubleshooting guide.



Motor Overload

When the light is on, it means the overload is tripped.
Reset overload.

TABLE OF CONTENTS

Machine Data Label	2
Table of Contents	3
How To Use This Manual	4
Safety	
Introduction & Safety Information	5
Owner/User Responsibility	5
IMPORTANT SAFETY INFORMATION	5
Propane Tank Safety Instructions	8
Operations	
Technical Specifications	10
Component Identification	13
Assembly Instructions	14
Installation Instructions	15
Exhaust Stack	17
Ventilation	17
Inspection and Testing Gas Piping	19
Shutdown Instructions	21
Storage Instructions	21
Maintenance	
Pump	22
Gas Burner	22
Heating Coil	23
Smart Relay Instructions	23
Programming Instructions	23
Troubleshooting	27
Burner Troubleshooting	29

HOW TO USE THIS MANUAL

This manual contains the following sections:

- How to Use This Manual
- Safety
- Operations
- Maintenance

The HOW TO USE THIS MANUAL section will tell you how to find important information for ordering correct repair parts.

Parts may be ordered from authorized dealers. When placing an order for parts, the machine model and machine serial number are important. Refer to the MACHINE DATA box which is filled out during the installation of your machine. The MACHINE DATA box is located on the inside of the front cover of this manual.

Model: _____
Date of Purchase: _____
Serial Number: _____
Dealer: _____
Address: _____
Phone Number: _____
Sales Representative: _____

The model and serial number of your machine is located on the back of the machine.
The SAFETY section contains important information

regarding hazardous or unsafe practices of the machine. Levels of hazards are identified that could result in product damage, personal injury, or severe injury resulting in death.

The OPERATIONS section is to familiarize the operator with the operation and function of the machine.

The MAINTENANCE section contains preventive maintenance to keep the machine and its components in good working condition. They are listed in this general order:

- Pump
- Gas Burner
- Heating Coil
- Smart Relay Instructions
- Troubleshooting
- Burner Troubleshooting

NOTE: If a service or option kit is installed on your machine, be sure to keep the KIT INSTRUCTIONS which came with the kit. It contains replacement parts numbers needed for ordering future parts

NOTE: The manual part number is located on the lower right corner of the front cover.

SAFETY

Introduction & Safety Information

Thank you for purchasing this Pressure Washer. We reserve the right to make changes at any time without incurring any obligation.

WARNING: If you do not follow these instructions exactly, a fire or explosion may result causing property damage, personal injury or death.

AVERTISSEMENT: Si ces directives ne sont pas suivies à la lettre, un incendie ou une explosion pourrait survenir et entraîner des dommages à la propriété, des lésions corporelles ou la mort.

Do not store or use gasoline or other flammable vapors and liquids in the vicinity of this or any other appliance.

WHAT TO DO IF YOU SMELL GAS

- Do not try to light any appliance.
- Do not touch any electrical switch; do not use any phone in your building.
- Immediately call your gas supplier from a neighbor's phone. Follow the gas supplier's instructions.
- If you cannot reach your gas supplier, call the fire department.

Installation and service must be performed by a qualified installer, service agency or the gas supplier.

Owner/User Responsibility

The owner and/or user must have an understanding of the manufacturer's operating instructions and warnings before using this pressure washer. Warning information should be emphasized and understood. If the operator is not fluent in English, the manufacturer's instructions and warnings shall be read to and discussed with the operator in the operator's native language by the purchaser/owner, making sure that the operator comprehends its contents.

Owner and/or user must study and maintain for future reference the manufacturers' instructions. The operator must know how to stop the machine quickly and understand the operation of all controls.

SAVE THESE INSTRUCTIONS

This manual should be considered a permanent part of the machine and should remain with it if machine is resold.

When ordering parts, please specify model and serial number. Use only identical replacement parts.

This machine is to be used only by trained operators.

Important Safety Information

WARNING: If you do not follow these instructions exactly, a fire or explosion may result, causing property damage, personal injury or loss of life.

AVERTISSEMENT: Si ces directives ne sont pas suivies à la lettre, un incendie ou une explosion pourrait survenir et entraîner des dommages à la propriété, des lésions corporelles ou la mort.



WARNING: To reduce the risk of injury, read operating instructions carefully before using.

AVERTISSEMENT: Pour réduire le risque de blessures, lire attentivement les instructions de fonctionnement avant l'utilisation.

1. Read the owner's manual thoroughly. Failure to follow instructions and warnings could cause malfunction of the machine and result in death, serious bodily injury and/or property damage.
2. Know how to stop the machine and bleed pressure quickly. Be thoroughly familiar with the controls.
3. Stay alert — watch what you are doing.
4. Use only your hand to push in or turn the gas control knob. Never use a tool. If the knob will not push in or turn by hand, don't try to repair it; call a qualified service technician.
5. All installations must comply with local codes. Contact your electrician, plumber, utility company or the selling dealer for specific details.

WARNING: Use vapor fuel only.

AVERTISSEMENT: Utiliser des vapeurs de carburant seulement

WARNING: Must be plugged into properly wired three hole grounded outlet that accommodates plug on power cord. Failure to comply could result in electrical shock.

AVERTISSEMENT: Doit être raccordé dans une sortie à trois trous mise à la masse et correctement câblée qui peut accueillir une fiche sur un cordon d'alimentation.

WARNING: To reduce the risk of electric shock, disconnect all electrical connections and shut-off gas valve before servicing.

AVERTISSEMENT: Pour réduire le risque de choc électrique, débrancher toutes les connexions électriques et la soupape de coupure des gaz

SAFETY

avant d'effectuer des opérations d'entretien.

DANGER: Improper connection of the equipment grounding conductor can result in a risk of electrocution. Check with a qualified electrician or service personnel if you are in doubt as to whether the outlet is properly grounded.

DANGER: Une mauvaise connexion du conducteur de terre de l'équipement peut entraîner un risque d'électrocution. Vérifier auprès d'un électricien qualifié ou du personnel d'entretien si vous avez des doutes quant à savoir si la sortie est correctement mise à la masse.



DANGER: Keep wand, hose, and water spray away from electric wiring or fatal electric shock may result.

DANGER: Garder la lance, le boyau et le jet d'eau à l'écart de tout câblage électrique ou des chocs électriques mortels pourraient survenir.

- To protect the operator from electrical shock, the machine must be electrically grounded. It is the responsibility of the owner to connect this machine to a grounded receptacle of proper voltage and amperage ratings. Do not spray water on or near electrical components. Do not touch machine with wet hands or while standing in water. Always disconnect power before servicing.

WARNING: Flammable liquids can create fumes which can ignite, causing property damage or severe injury.

AVERTISSEMENT: Des liquides inflammables peuvent produire des vapeurs qui peuvent s'enflammer, causant ainsi des dommages à la propriété ou des blessures graves.



WARNING: Risk of explosion — Operate only where open flame or torch is permitted. Do not spray flammable liquids.

AVERTISSEMENT: Risque d'explosion-Utiliser uniquement dans des endroits où l'utilisation d'une flamme nue ou d'une torche est permise. Ne pas pulvériser de liquides inflammables.



WARNING: Risk of fire — Do not change LP tanks when the product is operating or still hot.

AVERTISSEMENT: Risque d'incendie-Ne pas changer les réservoirs de pétrole liquide pendant que le produit est en marche ou encore chaud.

- Gas appliances shall be installed only in locations where combustible dusts and flammable gases or vapors are not present. Do not store or use gasoline near this machine.

WARNING: In the event of a pilot outage, wait at least five minutes to clear out any gas before relighting.

AVERTISSEMENT: En cas de panne de la veilleuse, attendre au moins cinq minutes pour permettre au gaz de se dissiper avant de rallumer.

- Keep operating area clear of all persons.



WARNING: High pressure spray can cause paint chips or other particles to become airborne and fly at high speeds. To avoid personal injury, eye, face, hand and foot safety devices must be worn.

AVERTISSEMENT: Un jet haute pression peut écailler la peinture ou provoquer l'émission d'autres particules dans l'air et leur projection à hautes vitesses. Pour éviter les lésions corporelles, une protection des yeux, du visage, des mains et des pieds doit être portée lors de l'utilisation de cet équipement.

- Always wear properly rated eye protection such as safety goggles or face shield while spraying. (Safety glasses do not provide full protection)



WARNING: This machine exceeds 85 db appropriate ear protection must be worn.

AVERTISSEMENT: Cette machine excède 85 dB et une protection de l'ouïe appropriée doit être portée.

SAFETY



WARNING: Risk of injury. Hot surfaces can cause burns. Use only designated gripping areas of spray gun and wand. Do not place hands or feet on non-insulated areas of the pressure washer.

AVERTISSEMENT: Risque de blessures. Les surfaces

chaudes peuvent causer des brûlures. Utiliser uniquement les zones de prise désignées du pistolet pulvérisateur et de la lance. Ne pas placer les mains ou les pieds sur des endroits non isolés de la laveuse à pression.

10. To reduce risk of injury, close supervision is necessary when a machine is used near children. Do not allow children to operate pressure washer. This machine must be attended during operation.



WARNING: Grip cleaning wand securely with both hands before starting. Failure to do this could result in injury from a whipping wand.

AVERTISSEMENT: Agripper la lance de nettoyage avec les deux mains avant de commencer. Le non-respect de

cette consigne pourrait mener à des blessures causées par le mouvement violent de la lance.

11. Never make adjustments on machine while in operation.
12. Move spray gun trigger lever into locked position before inserting the high pressure nozzle into the quick coupler. Be certain all quick coupler fittings are secured before using pressure washer.



WARNING: High pressure developed by these machines will cause personal injury or equipment damage. Keep clear of nozzle. Use caution when operating. Do not direct discharge stream at people or animals, or severe injury or death will result.

AVERTISSEMENT: La haute pression générée par ces machines causera des lésions corporelles ou des dommages à l'équipement. Se tenir à l'écart de la buse. Faire preuve de prudence lors de l'utilisation. Ne pas décharger directement le jet vers des personnes ou des animaux, car cela risquerait de causer des blessures graves ou même la mort.



WARNING: Protect machine from freezing.

AVERTISSEMENT: Protéger la machine contre le gel.

13. To keep machine in best operating conditions, it is important you protect machine from freezing. Failure to protect machine from freezing could cause malfunction of the machine and result in death, serious bodily injury, and/or property damage. Follow storage instructions specified in this manual.



WARNING: Risk of asphyxiation. Use this product only in a well ventilated area.

AVERTISSEMENT: Risque d'asphyxie: Utiliser ce produit uniquement dans un endroit bien ventilé.

14. Avoid installing machines in small areas or near exhaust fans. Adequate oxygen is needed for combustion or dangerous carbon monoxide will result.
15. Manufacturer will not be liable for any changes made to our standard machines or any components not purchased from us.
16. The best insurance against an accident is precaution and knowledge of the machine.



WARNING: Be extremely careful when using a ladder, scaffolding or any other relatively unstable location. The cleaning area should have adequate slopes and drainage to reduce the possibility of a fall due to slippery surfaces.

AVERTISSEMENT: Faire preuve d'une extrême prudence au moment d'utiliser une échelle, des échafaudages ou toute autre surface relativement instable. La zone de nettoyage doit avoir une pente et un drainage adéquats pour réduire la possibilité d'une chute due à une surface glissante.

17. Do not overreach or stand on unstable support. Keep good footing and balance at all times.
18. Do not operate this machine when fatigued or under the influence of alcohol, prescription medications, or drugs.

WARNING: Use vapor fuel only.

AVERTISSEMENT: Utiliser des vapeurs de carburant seulement.

SAFETY

19. The LP models are designed to run on vapor propane fuel. Do not use liquid fuel. Have a qualified serviceman install and service your equipment.
20. Never expose a spark or flame where there may be unburned gas present.
21. Install this machine about 2 feet from wall to provide adequate ventilation and servicing space. This equipment incorporates parts such as snap switches or similar parts that tend to produce arcs or sparks. Therefore, when located in a garage, it should be in a room or enclosure provided for the purpose or should be installed 18" (457mm) or more above the floor.
22. This equipment must be installed on noncombustible flooring and have a 36" (90cm) minimum working clearance.
23. Do not allow acids, caustic or abrasive fluids to pass through the pump.
24. Never run pump dry or leave spray gun closed longer than 3 minutes.
25. Exhaust gases should not be vented into a wall, a ceiling or a concealed space within a building. A draft diverter must be installed to prevent down draft and to allow for the cooling of exhaust temperatures. It is recommended to install the draft diverter 36" above the pressure washer stack; however, it can be installed at a lower height in special cases, such as when low ceilings are present. The draft diverter being right on top of the machine in cold freezing environments could potentially allow the coil to be frozen and damage the coil. Check local codes and standards for specific installation requirements. Exhaust gases that exceed 470°F (243°C) are not suitable for connection to Type B gas vents.

Example of Down Draft Diverter for Gas Fired Machines

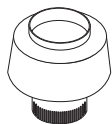

26. Before disconnecting discharge hose from water outlet, turn burner off and open spray gun to allow water to cool below 100° before stopping the machine. Then open the spray gun to relieve pressure. Failure to properly cool down or maintain the heating coil may result in a steam explosion.

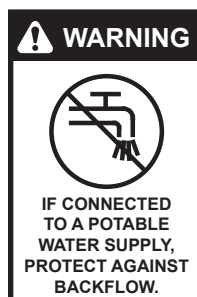

WARNING: *If connection is made to potable water supply, a back flow device must be provided.*

AVERTISSEMENT: *Si une connexion est établie avec un réseau d'eau potable, le réseau doit être protégé contre le retour d'eau.*



WARNING: *Do not spray machine or any people, animals or electrical parts.*

AVERTISSEMENT: *Ne pas vaporiser sur la machine ou les gens, les animaux ou les pièces électriques.*



Follow the maintenance instructions specified in the manual.

SAFETY

Propane Tank Safety Instructions

CAUTION: Only qualified persons should fill your LP-gas containers.

ATTENTION: Les contenants de gaz de pétrole liquéfié doivent être remplis uniquement par des personnes qualifiées.

1. Never allow your LP-gas container to be filled above the maximum safe level as indicated by a scale or the fixed liquid level gauge (outage). Do not use the visible gauge for filling.
2. Do not use a wrench or pliers to close the service valve or fixed liquid level gauge. These valves are designed to be closed leak-tight by hand or screwdriver as appropriate. If wrenches are necessary to stop a leak, the valve needs repair or replacement.
3. When tightening the POL Nut (left hand thread) on the service valve, draw it up snug with a proper wrench. This is a machined male brass fitting which seats securely against a female seat in the POL valve – no pipe dope is necessary. Acme/Type 1 valves have right handed threads which are secure when hand tight, and on the Quick Disconnect/Type 2 Valves, the male connection is inserted into the female connection on the cylinder valve. (No wrenches required for both the Acme and the Quick Disconnect.)
4. When using container, slowly open service valve all the way. Listen to the regulator. A continuous hiss may indicate a leak or an open valve on an appliance.
5. Check all tank and the line connections periodically to be sure they are tight. When testing for leaks, use approved leak detector solution – not matches.
6. Make certain your container is properly fastened in place.
7. Turn container with open part of container guard towards frame. This protects valves and regulator against flying rocks and mud. Transport container in the proper position in which it is used, with the valves closed and POL Plugs inserted for POL Valves or Dust Caps for Acme Valves. Secure the tank against falling or rolling.
8. Check for leaks after connecting. Apply approved leak detector solution to connection, turn off all burners and pilots, and open service valve. Leaks will be detected by the growth of the bubbles. If bubbles grow, tighten or repair the connection as needed. Repeat leak test until problem is corrected.
9. LP-gas is normally non-corrosive – you need not worry about the inside of your container. However, the outside should be kept free from rust by a periodic coat of paint in a light reflective color. It is very important to inspect and maintain the bottom and foot ring on the container.
10. Do not store LP-gas containers indoors or in enclosed areas. Do not expose LP-gas container to heat. Always store with service valve closed and plugged as required.
11. Do not attempt to repair any containers, container valves, regulator or appliances by yourself. Use only trained certified LP-gas service personnel to perform repairs.

OPERATIONS

Technical Specifications

Model #	Pump Volume @ Pump Head	Pump Pressure at Pump Head	Burner Type	Motor HP	Machine Voltage	Total Machine Amperage	Machine Weight
921P	4.0 GPM /234 GPH	2300 PSI	LP Gas Fired, 360,997 BTU/Hr.	6.2 HP	208VAC/ 60Hz/1Ph	28 Amps	661 Lbs
921N	4.0 GPM / 228 GPH	2300 PSI	Natural Gas Fired, 364,835 BTU/Hr.	6.2 HP	208VAC/ 60Hz/1Ph	28 Amps	661 Lbs
926P	4.0 GPM / 234 GPH	2000 PSI	Natural Gas Fired, 360,997 BTU/Hr.	5.0 HP	575VAC/ 60Hz/3Ph	7 Amps	567 Lbs
926N	4.0 GPM / 228 GPH	2000 PSI	Natural Gas Fired, 364,835 BTU/Hr.	5 HP	575VAC/ 60Hz/3Ph	7 Amps	567 Lbs
942P	4.0 GPM / 234 GPH	2000 PSI	LP Gas Fired, 360,997 BTU/Hr.	5.0 HP	200VAC/ 60Hz/3Ph	18 Amps	567.5 Lbs
942N	4.0 GPM / 234 GPH	2000 PSI	Natural Gas Fired, 364,835 BTU/Hr.	5.0 HP	200VAC/ 60Hz/3Ph	18 Amps	567.5 Lbs
943P	4.0 GPM / 234 GPH	2000 PSI	LP Gas Fired, 360,997 BTU/Hr.	5.0 HP	230VAC/ 60Hz/1Ph	25 Amps	611 Lbs
943N	4.0 GPM / 234 GPH	2000 PSI	Natural Gas Fired, 364,835 BTU/Hr.	5.0 HP	230VAC/ 60Hz/1Ph	25 Amps	611 Lbs
944P	4.0 GPM / 234 GPH	2000 PSI	LP Gas Fired, 360,997 BTU/Hr.	5.0 HP	230VAC/ 60Hz/3Ph	25 Amps	567 Lbs
944N	4.0 GPM / 234 GPH	2000 PSI	Natural Gas Fired, 364,835 BTU/Hr.	5.0 HP	230VAC/ 60Hz/3Ph	25 Amps	567 Lbs
945P	4.0 GPM / 234 GPH	2000 PSI	LP Gas Fired, 360,997 BTU/Hr.	5.0 HP	460VAC/ 60Hz/3Ph	8 Amps	567 Lbs
945N	4.0 GPM / 234 GPH	2000 PSI	Natural Gas Fired, 364,835 BTU/Hr.	5.0 HP	460VAC/ 60Hz/3Ph	8 Amps	567 Lbs
1451P	4.0 GPM /234 GPH	3000 PSI	LP Gas Fired, 360,997 BTU/Hr.	8.2 HP	208VAC/ 60Hz/1Ph	36.5 Amps	615 Lbs
1451N	4.0 GPM / 234 GPH	3000 PSI	Natural Gas Fired, 364,835 BTU/Hr.	8.2 HP	208VAC/ 60Hz/1Ph	36.5 Amps	615 Lbs
1452P	4.0 GPM / 234 GPH	3000 PSI	LP Gas Fired, 360,997 BTU/Hr.	7.5 HP	208VAC/ 60Hz/3Ph	24 Amps	612 Lbs
1452N	4.0 GPM / 234 GPH	3000 PSI	Natural Gas Fired, 364,835 BTU/Hr.	7.5 HP	208VAC/ 60Hz/3Ph	24 Amps	612 Lbs
1453P	4.0 GPM / 234 GPH	3000 PSI	LP Gas Fired, 360,997 BTU/Hr.	7.5 HP	230VAC/ 60Hz/1Ph	34 Amps	644 Lbs
1453N	4.0 GPM / 234 GPH	3000 PSI	Natural Gas Fired, 364,835 BTU/Hr.	7.5 HP	230VAC/ 60Hz/1Ph	34 Amps	644 Lbs
1454P	4.0 GPM / 234 GPH	3000 PSI	LP Gas Fired, 360,997 BTU/Hr.	7.5 HP	230VAC/ 60Hz/3Ph	24 Amps	610 Lbs
1454N	4.0 GPM / 234 GPH	3000 PSI	Natural Gas Fired, 364,835 BTU/Hr.	7.5 HP	230VAC/ 60Hz/3Ph	24 Amps	610 Lbs
1455P	4.0 GPM / 234 GPH	3000 PSI	LP Gas Fired, 360,997 BTU/Hr.	7.5 HP	460VAC/ 60Hz/3Ph	12 Amps	610 Lbs

OPERATIONS

Technical Specifications

Model #	Pump Volume @ Pump Head	Pump Pressure at Pump Head	Burner Type	Motor HP	Machine Voltage	Total Machine Amperage	Machine Weight
1455N	4.0 GPM / 234 GPH	3000 PSI	Natural Gas Fired, 364,835 BTU/Hr.	7.5 HP	460VAC/ 60Hz/3Ph	12 Amps	610 Lbs
1456P	4.0 GPM / 234 GPH	3000 PSI	LP Gas Fired, 360,997 BTU/Hr.	8.2 HP	"575VAC/ 60Hz/1Ph"	10 Amps	610 Lbs
1456N	4.0 GPM / 234 GPH	3000 PSI	Natural Gas Fired, 390,025 BTU/Hr.	8.2 HP	"575VAC/ 60Hz/1PH"	10 Amps	610 Lbs
1473P	5 GPM / 300 GPH	3000 PSI	LP Gas Fired, 378,617 BTU/Hr.	10 HP	"230VAC/ 60Hz/1Ph"	42 Amps	642 Lbs
1473N	5 GP / 300 GPH	3000 PSI	Natural Gas Fired, 390,025 BTU/Hr.	10 HP	"230VAC/ 60Hz/1Ph"	42 Amps	642 Lbs
1474P	5 GPM / 300 GPH	3000 PSI	LP Gas Fired, 378,617 BTU/Hr.	10 HP	"230VAC/ 60Hz/3Ph"	29 Amps	619 Lbs
1474N	5 GPM/ 300 GPH	3000 PSI	LP Gas Fired, 390,025 BTU/Hr.	10 HP	"230VAC/ 60Hz/3Ph"	29 Amps	619 Lbs
1475P	5.0 GPM / 300 GPH	3000 PSI	LP Gas Fired, 360,997 BTU/Hr.	10 HP	"200VAC/ 60Hz/3Ph"	34 Amps	618 Lbs
1475N	5.0 GPM/ 300 GPH	3000 PSI	LP Gas Fired, 378,617 BTU/Hr.	10 HP	"200VAC/ 60Hz/3Ph"	34 Amps	618 Lbs
1476P4	5 GPM / 300 GPH	3000 PSI	LP Gas Fired, 378,617 BTU/Hr.	10 HP	"460VAV/ 60Hz/3ph"	17 Amps	619 Lbs
1476N	5 GPM / 300 GPH	3000 PSI	Natural Gas Fired, 390,025 BTU/Hr.	10 HP	"460VAV/ 60Hz/3ph"	17 Amps	619 Lbs

Dimensions

Model #	Shipping Weight	Exhaust Stack Size	Machine Dimensions
921P	691 Lbs	8"	L 51.75" X 21.3" X 51.5"
921N	691 Lbs	8"	L 51.75" X 21.3" X 51.5"
926P	647 Lbs	8"	L 51.75" X 21.3" X 51.5"
926N	647 Lbs	8"	L 51.75" X 21.3" X 51.5"
942P	647.5 Lbs	8"	L 51.75" X 21.3" X 51.5"
942N	647.5 Lbs	8"	L 51.75" X 21.3" X 51.5"
943P	691 Lbs	8"	L 51.75" X 21.3" X 51.5"
943N	691 Lbs	8"	L 51.75" X 21.3" X 51.5"
944P	647 Lbs	8"	L 51.75" X 21.3" X 51.5"
944N	647 Lbs	8"	L 51.75" X 21.3" X 51.5"

OPERATIONS

Dimensions

Model #	Shipping Weight	Exhaust Stack Size	Machine Dimensions
945P	647 Lbs	8"	L 51.75" X 21.3" X 51.5"
945N	647 Lbs	8"	L 51.75" X 21.3" X 51.5"
1451P	695 Lbs	8"	L 51.75" X 21.3" X 51.5"
1451N	695 Lbs	8"	L 51.75" X 21.3" X 51.5"
1452P	692 Lbs	8"	L 51.75" X 21.3" X 51.5"
1452N	692 Lbs	8"	L 51.75" X 21.3" X 51.5"
1453P	724 Lbs	8"	L 51.75" X 21.3" X 51.5"
1453N	724 Lbs	8"	L 51.75" X 21.3" X 51.5"
1454P	690 Lbs	8"	L 51.75" X 21.3" X 51.5"
1454N	690 Lbs	8"	L 51.75" X 21.3" X 51.5"
1455P	690 Lbs	8"	L 51.75" X 21.3" X 51.5"
1455N	690 Lbs	8"	L 51.75" X 21.3" X 51.5"
1456P	690 Lbs	8"	L 51.75" X 21.3" X 51.5"
1456N	690 Lbs	8"	L 51.75" X 21.3" X 51.5"
1473P	722 Lbs	8"	L 51.75" X 21.3" X 51.5"
1473N	722 Lbs	8"	L 51.75" X 21.3" X 51.5"
1474P	699 Lbs	8"	L 51.75" X 21.3" X 51.5"
1474N	699 Lbs	8"	L 51.75" X 21.3" X 51.5"
1475P	698 Lbs	8"	L 51.75" X 21.3" X 51.5"
1475N	698 Lbs	8"	L 51.75" X 21.3" X 51.5"
1476P	699 Lbs	8"	L 51.75" X 21.2" X 51.5"
1476N	699 Lbs	8"	L 51.75" X 21.2" X 51.5"

OPERATIONS

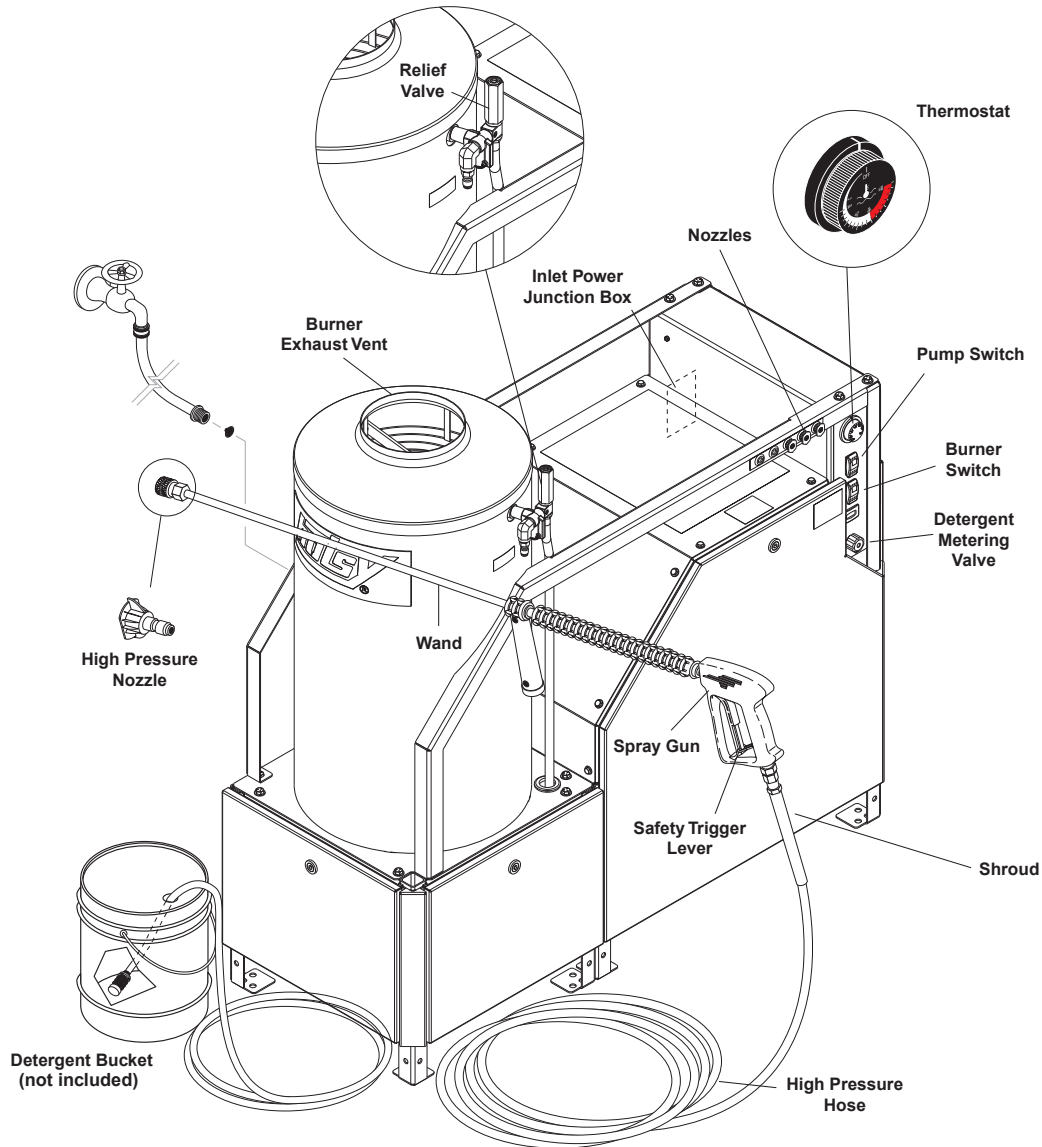

Component Identification

Pump — Develops high pressure by pumping water volume through nozzle.

Spray Gun — Controls the application of water and detergent onto cleaning surface with trigger device. Includes safety latch.

Detergent Metering Valve — Controls detergent mixture.

Wand — Must be connected to the spray gun.

Relief Valve — Safety device preventing over-pressurization.

High Pressure Hose — Connect one end to water pump discharge nipple and the other end to spray gun.

Pressure Nozzle — Inserted into wand quick coupler to develop pressure

Adjustable Thermostat — Prevents water temperature from exceeding high temperatures. Is not used to maintain constant temperature setting.

Safety Trigger Lever — Prevents accidental triggering of spray gun while inserting a high pressure nozzle.

Bend Restrictor (Shroud) — This shroud has different lengths depending on pressure. The largest shroud must be connected to the spray gun to protect operator if hose becomes separated.

OPERATIONS

Assembly Instructions

Unpacking

Unpack carefully. Wear safety glasses or goggles while unpacking, assembling or operating pressure washer. If there are missing components or hidden damage immediately contact dealer or carrier concerning discrepancies.

1. Cut strapping band from pressure washer and pallet.
2. Remove pressure washer from pallet.

Parts Included

- Pressure Washer
- Pressure Hose
- Wand
- Parts Box Containing:
 - Pressure Nozzles (3 ea.)
 - Trigger Gun
 - Operating Instructions and Parts Manual

Tools Required

- 10" Adjustable Crescent Wrenches (2 ea.)
- Blade Screwdriver
-

Pressure Hose, Wand and Wand Holder

1. Use teflon tape on plumbing connections to prevent leakage.
2. Install pressure hose on machine as shown.
3. Assemble wand components as shown. Connect pressure hose to trigger gun.

NOTE: The nozzle is not to be installed at this time.

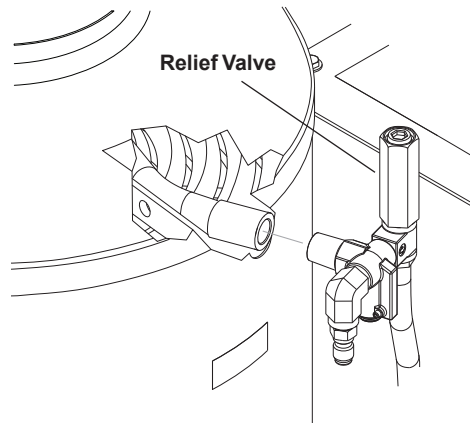

Note: Pressure relief valve should be inspected and tested annually.

4. Make sure that all plumbing connections are tight.

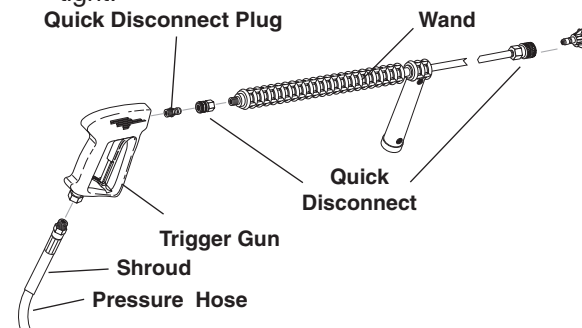

Note: Longer shroud at end of hose should be connected to spray gun.

OPERATIONS

Installation Instructions

Getting Started

IMPORTANT: Proper installation will assure satisfactory performance, longer service life and lower maintenance costs.

Location

The location should protect machine from damaging environmental conditions, such as wind, rain and freezing.

1. The machine should be run on a level surface where it is not readily influenced by outside sources such as strong winds, freezing temperatures, rain, etc. The machine should be located considering accessibility for the replacing of components and the refilling of detergents, adjustments and maintenance. Normal precautions should be taken by the operator of the machine to prevent excess moisture from reaching the machine.
2. It is recommended that a partition be made between the wash area and machine to prevent direct spray from the spray gun from coming in contact with the machine. Excess moisture reaching the power unit or electrical controls will reduce the machine's life and may cause electrical shorts.
3. During installation of the machine, beware of poorly ventilated locations or areas where exhaust fans may cause an insufficient supply of oxygen. Sufficient combustion can only be obtained when there is a sufficient supply of oxygen available for the amount of fuel being burned. If it is necessary to install a machine in a poorly ventilated area, outside fresh air may have to be piped to the burner and a fan installed to bring the air into the area.
4. Do not locate near any combustible material. Keep all flammable material at least 20 feet away. Allow enough space for servicing the machine. Local code will require certain distances from floor and walls. (Two feet away should be adequate).

WARNING: Avoid small areas or near exhaust fans.

AVERTISSEMENT: Éviter les petites superficies ou les surfaces à proximité des ventilateurs d'extraction.

Gas Codes

Confer with local gas company and with proper municipal officials regarding any specific code

or regulations governing the installation. The installation must conform to local codes (U.S., ANSI Z223.1/NFPA54 National Fuel Gas Code; Canada, CAN 1-B149 Installation Code).

Electrical

The machine, when installed, must be electrically grounded in accordance to local codes. Check for proper power supply using a volt meter; check the serial plate for the correct requirements.

Gas Piping

This machine shall be rigidly connected to the gas piping outlet and equipped with external manual shut-off valves adjacent to such machine. All gas piping shall be approved and installed in accordance with the Uniform Mechanical Code.

Install a gas union in the gas line adjacent to and upstream from the control manifold and downstream from the manual main shut-off valve. A 1/8" NPT plugged tapping accessible for test gauge connection shall be installed immediately upstream of the gas supply connection for the purpose of determining the gas supply pressure to the burner, and to prevent damage to gas valve.

If a manual gas shut off valve is not in the gas supply line within six feet of the machine and in an accessible location, one shall be installed.

Union Connection

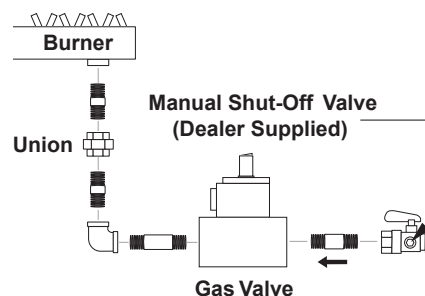

The following pipe sizes are just recommendations. Always consult a local plumber and venting contractor for local codes and regulations during installation.

Pipe Sizing Chart for Natural Gas

The following chart is based on gas pressure in the range 0-0.5 psi, specific gravity of 0.6 and pressure loss of 0.5" W.C. Numbers are for straight schedule 40 pipe; fittings further reduce capacity. For example, in 1" size, an elbow is equivalent to about 2.6 feet of pipe and a tee is equivalent to about 5.2 feet of pipe.

OPERATIONS

Length of Pipe (ft.)	Iron Pipe Size				
	3/4"	1"	1 -1/4"	1- 1/2"	2"
10	360	680	1400	2100	3950
20	250	465	950	1460	2750
30	200	375	770	1180	2200
40	170	320	660	990	1900
50	151	285	580	900	1680
60	138	260	530	810	1520
70	125	240	490	750	1400
80	118	220	460	690	1300
90	110	205	430	650	1220
100	103	195	400	620	1150
150	84	160	325	500	950
200	72	135	280	430	800

Maximum capacity of pipe in cubic feet/hr of natural gas (Multiply values by 1000 to get nominal BTU/hr capacity.)

LP-Gas (Liquid petroleum gas or propane)

LP-gas is gas compressed into liquid form for easy transportation and storage. It is also known as propane or bottle gas. (Propane tanks are not supplied with this equipment.)

LP-gas is flammable, is always contained under pressure and the liquid can freeze skin. Therefore, in the interest of safety, it is important to understand the basic facts about LP-gas and LP-gas containers. Federal DOT (Department of Transportation) regulations require periodic inspections and re-qualifications of cylinders. **DO NOT USE** damaged or rusted containers.

DO NOT store LP-gas containers indoors or in enclosed areas. Do not expose LP-gas container to heat. Always store with service valve closed and plugged as required.

CAUTION: Use LP-gas containers in proper position.

ATTENTION: Utiliser des contenants de gaz de pétrole liquéfié en position appropriée.

Most LP-gas pressure washer heaters are designed to operate on LP-gas vapor only. Therefore, all LP-gas containers designed for vapor service must be transported, installed and used in the proper position. Do not transport, install or use a vertical cylinder in a horizontal or upside down position. Proper care must be taken to position a horizontal container in the correct position for vapor withdrawal. Liquid LP-gas could enter the system designed for

vapor only, possibly creating a hazardous condition. Always use a POL plug installed on a POL valve or a dust cap on an ACME/Type 1 valve when transporting or storing disconnected containers (full or empty). Check for leaks after connecting. Apply approved leak detector solution to connection, turn off all burners and pilots and open service valve. Leaks will be detected by the growth of bubbles. If bubbles grow, tighten or repair the connection as needed. Repeat leak test until problem is corrected. Check all tank and the line connections periodically to be sure they are tight. When testing for leaks, use approved leak detector solution — not matches.

Improved Regulation: The second stage regulator receives a relatively uniform pressure from the first stage regulator. This helps the second stage regulator to maintain appliance pressure at a nearly constant 11" W.C.

Filling the LP-Gas Container

Only qualified persons should fill your LP-gas containers.

Les contenants de gaz de pétrole liquéfié doivent être remplis uniquement par des personnes qualifiées.

Caution: Overfilling is hazardous!

ATTENTION: Le remplissage excessif est dangereux!

DO NOT allow your LP-gas container to be overfilled. Stop filling when liquid appears at the fixed level gauge. Bleed off excess propane in a safe area. Most LP-gas containers are equipped with a fixed liquid level gauge which contacts the liquid level at 80% of container capacity, allowing 20% for expansion. LP-gas containers not equipped with a fixed liquid level gauge can only be filled by weight. In cold climates, in order to keep vaporization of LP-gas at the highest level, keep the fuel levels above 50%.

Room Vents for Combustion and Ventilation Air

Properly sized vents are vital for the safe and efficient operation of a pressure washer installed in a confined space. When combustion and ventilation air are supplied from inside the building, each opening must have an area of one square inch for every 1,000 BTUH input. When combustion air is supplied from the outside, each opening must have an area of one square inch for every 2,000 BTUH for horizontal ducts and one square inch for every 4,000 BTUH for vertical ducts (refer to NFPA 54).

OPERATIONS

NOTE: Air vents for combustion and ventilation and exhaust flue sizing must conform to methods outlined in current American Standard (ANSI-Z223.1), National Fuel Gas Code of National Standard of Canada CSA-149.1 and CSA-149.2 "Installation Code for Gas Burner Appliances".

Exhaust Stack

The purpose of venting a gas pressure washer is to completely remove all products of combustion and to vent gasses to the outside air without condensation in the vent or spillage at the draft hood (except in cases of downdraft or poor stack conditions).

To assure correct venting, use a strong, gas-tight insulated pipe with a cross section equal to that of the flue collar or draft hood outlet and of sufficient vertical height.

During vent installation, avoid sharp turns, long horizontal runs and improper pitches. Maintain proper support of vent connectors and joints, observe clearances from all combustibles and top the vent outlet with an approved cap.

All venting installations must conform to local codes. In the absence of local codes, refer to "National Fuel Gas Code" NFPA 54 and be constructed of materials approved by the Uniform Building Code.

Vents penetrating ceilings or walls should be double-wall approved appliance vents and should be one to two inches from combustibles. Vents passing through enclosed spaces and vents exposed to the weather should also be the double-wall type. Sometimes vents have to be built of such great length that they come apart at their joints under their own weight. These should be screwed together at the joints with sheet metal screws, usually three per joint. If the inspector indicates that the vent is too close to combustibles, it may be necessary to chisel away some of the combustible or route the vent pipe around the combustible. The cross-sectional area of any flue shall not be less than the cross-sectional area of the flue vent connection outlet of machine.

Ventilation

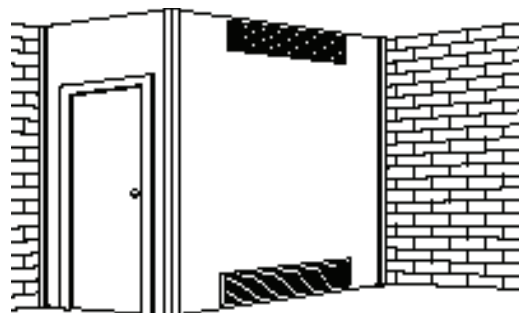

Illustration showing air openings necessary to supply air for combustion when installed in an enclosed room.

The pressure washer includes a collar that will mate with standard HVAC ducting. The user will be responsible for installation of an exhaust stack. The exhaust stack should include a Draft Diverter/ Inducer, Damper, Sampling Port and Rain Cap. An adapter can be installed between the collar and stack to adjust the diameter from 10" to 8" or 12" to 10".

Venting

DANGER: DO NOT run machine indoors or in an enclosed area without proper ventilation, as exhaust fumes may be hazardous to your health.

DANGER: NE PAS faire fonctionner la machine à l'intérieur ou dans un endroit fermé sans une ventilation appropriée, car les gaz d'échappement pourraient comporter des dangers pour la santé.

DANGER: DO NOT operate machine in areas where flammable vapors (gasoline, solvents, etc.) may be present, as this machine may ignite the vapors.

DANGER: NE PAS utiliser la machine dans des endroits où des vapeurs inflammables (essence, solvants, etc.) pourraient être présentes, car cette machine pourrait enflammer les vapeurs

CAUTION: All venting must be in accordance with applicable federal and state laws, and local ordinances. This machine is not to be connected to a type B gas vent. Consult local heating contractors.

ATTENTION: Toute la ventilation doit être conforme aux lois fédérales et de l'État ou de la province, et aux réglementations locales applicables. Cette machine ne doit pas être raccordée à un évent de gaz de type B. Consulter les entrepreneurs de chauffage locaux.

OPERATIONS

If the pressure washer is to be used in an enclosed area, a flue must be installed to vent burner exhaust to the outside atmosphere. Be sure the flue is the same size as the burner exhaust vent on the pressure washer lid. Poor draft will cause the pressure washer to soot and not operate properly. When selecting the location for installation, beware of poorly ventilated locations or areas where exhaust fans may cause an insufficient supply of oxygen. Proper combustion can only be obtained when there is a sufficient supply of oxygen available for the amount of fuel being burned. If it is necessary to install the machine in a poorly ventilated area, outside fresh air may have to be piped to the burner and a fan installed to bring sufficient air into the machine. Locate the pressure washer so that the flue will be as straight as possible and protrude through the roof at a proper height and location to provide adequate draft.

Hotsy natural and LP gas series pressure washers that incorporate a natural draft burner assembly designed to heat water that comes from the pressure washer pump require a draft diverter and vent pipe for exhausting to the outside. This operator's manual indicates this machine is to be vented through the ceiling using straight pipe or 45° elbows. It also discourages the use of any 90° venting elbows which restrict air flow through the burner causing poor burner conditions. If this machine is going to be installed to a 90° or extended exhaust vent run length which may restrict air flow it is recommended that a contractor install a power vent. When a contractor has found it impossible to vent through the ceiling then power venting can be calculated to help eliminate exhaust restriction on this natural draft machine. This draft inducer (power vent) must be installed by a licensed contractor who can calculate size, operation connections and associated dampeners. Hotsy is not a licensed contractor and as such we are unable to make recommendations for suitable make and model of power vents. It is important that the licensed contractor consult local building codes. Hotsy can only make recommendations and the selection of the venting must take into account the type of roof or wall material it contacts which could change the vent requirement for compliance with local building codes. Size the stack according to the following (see also applicable local and national standards regarding installation of gas-fired appliances):

- | | | |
|------------------|------------|-----------|
| • 3.5 to 4.4 gpm | 10" Collar | 8" Stack |
| • 4.5 to 5.5 gpm | 10" Collar | 10" Stack |
| • 6.3 gpm | 12" Collar | 10" Stack |
| • 8 – 10 gpm | 12" Collar | 12" Stack |

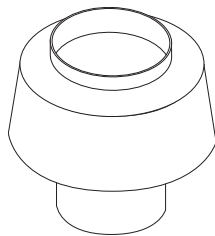

Draft Diverter Required

8.717-728.0	8"
9.801-040.0	10"
8.717-730.0	12"

Draft Diverter/Hood The draft required to vent combustion gases is created by the heat inside the pressure washer coil. A draft diverter helps improve draft into the stack without pulling more air through the combustion box and decreasing combustion efficiency. The draft diverter can also help prevent back drafting that can inhibit combustion. See page 8 for recommended installation instructions.

Power Vent (Draft Inducer) If this machine is going to be installed on a 90° or extended exhaust vent run length which may restrict air flow it is recommended that a contractor install a power vent. When a contractor has found it impossible to vent straight through the roof power venting is recommended to help eliminate exhaust restriction of this natural draft machine. This draft inducer (power vent) must be installed by a licensed contractor who can calculate size, operation connections and associated dampeners. Since we are a manufacturer and not a licensed contractor and as such we are unable to make recommendations for suitable make and model of power vents and compliance with local building codes.

Damper An exhaust stack can reduce thermal efficiency by drawing in too much combustion air. This can be controlled by adding a damper just below the draft diverter. 8.753-473.0 - 8" Damper, 8.753-474.0 - 10" Damper, 8.753-418.0 - 12" Damper.

NOTE: Closing the damper can create high levels of CO in the exhaust. Adjustments to the damper should only be performed by a trained technician using a flue gas analyzer. If an analyzer is not used the damper should be set in the fully open position.

OPERATIONS

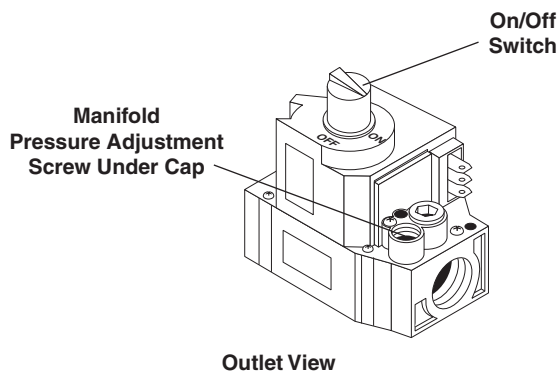

Sampling Port A port for sampling flue gases and measuring the flue gas temperature should be placed 18" above the flue collar. The port should be covered when sampling is not being performed. The size of the port should be only slightly larger than the probe for the flue gas analyzer.

Rain Cap A rain cap should be installed on top of the stack to prevent rain water, leaves and debris from entering the stack. Your installer may also recommend specialty caps for high wind areas or cold weather zones to help prevent back drafting. 8.717-731.0 - 10" Raincap, 8.717-732.0 - 12" Raincap

Water Source

The water source for the machine should be supplied by a 5/8" I.D. garden hose with a city water pressure of not less than 30 PSI. If the water supply is inadequate, or if the garden hose is kinked, the machine will run very rough and the burner will not fire.

Water Connection

Connect the high pressure hose by pulling the coupler collar back and then inserting it onto the discharge nipple. Secure it by pushing the collar forward.

Attach the wand into the spray gun using teflon tape on the pipe threads to avoid leaks.

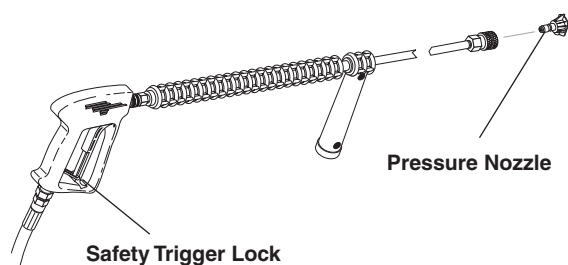

Inspection and Testing Gas Piping

The building structure should not be weakened by installing the gas piping. The piping should not be supported by other piping, but should be firmly supported with gas hooks, straps, bands or hangers. Butt or lap welded pipe should not be run through or

in an air duct or clothes chute.

Before turning gas under pressure into piping, all openings from which gas can escape should be closed. Immediately after turning on gas, the system should be checked for leaks. This can be done by watching the

1/2 cubic foot test dial for 5 minutes for any movement or by soaping each pipe connection and watching for bubbles. If a leak is found, make the necessary repairs and repeat the above test. Defective pipes or fittings should be replaced and not repaired. Never use a flame or fire in any form to locate gas leaks — use a soap solution.

After the piping and meter have been checked completely, purge the system of air. DO NOT bleed the air inside an enclosed room.

During pressure testing of the system at test pressures in excess of 1/2 PSIG, the pressure washer and its individual shut-off valve must be disconnected from gas supply piping system or damage to the gas valve will occur.

Gas Pressure

The ideal incoming gas pressure is 11 w.c.i (water column inches). Minimum is 9 w.c.i., maximum is 14 w.c.i. or 1/2 PSIG. The correct operating manifold pressure for natural gas is 2.8 w.c.i. The operating manifold pressure for propane gas is 7.5 w.c.i. By adjusting the gas valve pressure regulator between 3 and 4 w.c.i. a side range can be achieved for natural gas.

If the desired input rating cannot be obtained within the above manifold pressure adjusting range, then the next size larger or smaller burner orifice should be used.

The gas pressure coming out of the regulator and going to the burner ring has been factory set for elevations of 0 to 2000 ft. Altitudes greater than 2000 ft will require adjustments to the gas manifold pressures. Consult your local service dealer for high altitude adjustments. In Canada, certification for installation at altitudes over 4500 feet above sea level is the jurisdiction of local authorities. You should not readjust the burner ring gas pressure. If you replace your gas valve, you will need to adjust the new valve. Refer to your machine's specification plate for the correct pressure setting. Follow the installation and adjustment instructions provided with your replacement valve.

NOTE: Air for combustion and ventilation along with exhaust flue sizing must conform to methods outlined in current American Standard (ANSI-Z223.1) National Fuel Gas Code or National Standard of Canada CSA-149.1 and CSA-149.2 "Installation Code for Gas Burning Appliances".

OPERATIONS

Operation Instructions

Before Starting

1. Read all manuals provided with this pressure washer. Become familiar with location and function of all operating and safety controls.

WARNING: Check hoses, fittings, wand, trigger gun and fuel connections daily for signs of wear, cracks and looseness, and replace as needed.

AVERTISSEMENT: Vérifier les boyaux, les raccords, le pistolet à gâchette et les connexions de carburant pour la présence de traces d'usure, de fissures et de desserrement; remplacer au besoin.

2. Connect water supply hose to the standard garden hose connector. The water faucet and supply hose must be capable of providing 6.0 GPM.
3. This machine was factory built for natural gas/propane. See instructions under Fuel Supply.
4. Check pump oil level.
5. If detergents are to be used, only use detergents intended for pressure washers. Follow instructions on the detergent container.

IMPORTANT: Before installing pressure nozzle on initial start-up, turn on the water supply, start the pump by pressing the pump ON switch, and hold the wand trigger open until water appears at the end of the wand. Allow water to run from the end of the wand until clear to prevent the nozzle from clogging.

6. Install the pressure nozzle on end of wand, refer to illustration below.

IMPORTANT: The trigger gun provided with this pressure washer is equipped with a manual trigger lock to prevent accidental operation of the trigger gun, refer to figure above. The safety trigger lock should be used whenever the trigger gun is not in use.

IMPORTANT: On initial start-up or if maintenance has been performed on the burner assembly, it will be necessary to bleed the air from the gas line before the pilot will light.

7. If you are running the machine for the first time, or have performed maintenance on the burner assembly, there will be air in the gas line. To bleed the air from the gas line run the pressure washer with pump and burner switches on and thermostat on highest setting. Squeeze the trigger of the trigger gun for 15 seconds. If the burner has not ignited, release the trigger for 5 seconds, then squeeze for 15 seconds. If the burner has not ignited after 10 tries, see the Troubleshooting Guide in this manual.

CAUTION: Have a qualified gas service technician modify, install and service your equipment.

ATTENTION: La modification, l'installation et l'entretien de l'équipement doivent être confiés à un technicien d'entretien qualifié dans le domaine du gaz.

DANGER: Never expose a spark or flame where there may be unburned gas present.

DANGER: Ne jamais exposer les endroits où il pourrait y avoir présence de gaz non brûlé à une étincelle ou une flamme.

DANGER: Some gases are heavier than air and will spill out on the floor in the 2 to 3 minutes required for the safety pilot valve to close off gas supply. Therefore, always provide adequate space and ventilation around these units.

DANGER: Certains gaz sont plus lourds que l'air et s'accumuleront au sol le temps requis pour la soupape de sûreté de la veilleuse pour couper l'alimentation en gaz.

To Start

WARNING: Risk of injection or severe injury - Keep clear of nozzle - DO NOT direct discharge stream at persons - This machine is to be used only by qualified operators.

AVERTISSEMENT: Risque d'injection et de blessures graves. Se tenir à l'écart du jet. ne pas diriger le jet de sortie vers d'autres personnes. Confier l'utilisation de ce matériel à un opérateur qualifié.

WARNING: Wear eye, ear, hand, foot and skin protection at all times while operating pressure washer.

AVERTISSEMENT: Porter une protection des yeux, des mains, des pieds et de la peau en tout temps en utilisant la laveuse à pression.

WARNING: Before changing pressure nozzle, engage manual trigger gun lock.

AVERTISSEMENT: Avant de changer le buse de projection, engager le dispositif de verrouillage manuel du pistolet à gâchette.

IMPORTANT: The water must be turned on before starting. Running the pump dry will cause damage and void warranty.

IMPORTANT: Do not allow the machine to run with trigger of the trigger gun released for more

OPERATIONS

than 10 minutes at any one time or damage to pump may occur.

1. Turn ON water supply.
2. Turn ON gas supply.
3. Hold wand firmly, release trigger of trigger gun and turn pump switch ON. Squeeze trigger of trigger gun and allow air to purge from system.
4. If HOT water is desired, adjust the thermostat to the proper temperature and turn burner switch ON. Squeeze trigger of trigger gun. The pilot will automatically light, quickly followed by the firing of the burner ring. When the trigger of the trigger gun is released or when the thermostat temperature setting is reached, the burner will automatically turn off.

IMPORTANT: If ignition or flame failure is experienced, discontinue use of pressure washer at once. Turn off burner and shut off fuel supply. Have cause of failure corrected by an authorized service technician before use of pressure washer is continued.

To Clean

WARNING: Risk of injection or severe injury - Keep clear of nozzle - Do not direct discharge stream at persons - This machine is to be used only by qualified operators.

AVERTISSEMENT: Risque d'injection et de blessures graves. Se tenir à l'écart du jet. ne pas diriger le jet de sortie vers d'autres personnes. Confier l'utilisation de ce matériel à un opérateur qualifié.

1. Insert detergent inlet line into container of mixed detergent. Open detergent ON/OFF valve. The detergent will be pulled automatically into the system. Allow detergent to reach end of wand before proceeding to step 3.
2. Select pressure nozzle with spray pattern that matches your cleaning needs. Engage manual trigger lock and install selected nozzle.
3. Wash from the bottom to the top, using side to side motions. This washes away heavy dirt and allows the detergent to soak as you work toward the top.
4. Do not wash at a 90° angle to the work (straight at it). This will allow water to splash back at you and reduces your cleaning power. Wash at a 30° to 60° angle to the work. This will allow the water to splash away from you and the water will wash the dirt away faster and easier.
5. Use the width of the spray pattern to wash in

a wide path. Overlap spray paths for complete coverage. Wash from side to side, using slow, steady motions.

6. The nozzle should be 12" to 24" from work, closer for tough areas. Be careful on painted or delicate surfaces, the pressure may damage surface if nozzle is too close.
7. Small parts should be washed in a basket and larger, lightweight parts should be clamped down so the pressure does not push them away.
8. Close the detergent ON/OFF valve to permit rinse. Always rinse with cold water after using detergents. Rinse from the top to the bottom to prevent detergent from dripping onto a rinsed area. For the best results, contact your Hotsy dealer to help you select the best detergent for your application.

Shutdown Instructions

To Stop

1. If detergents were used, draw clear water through the detergent line to purge detergent. Failure to do so may clog detergent injector valve.
2. Turn burner switch off and continue spraying, allowing the water to cool to below 100°F.
3. Turn pump switch OFF.
4. Turn water supply OFF.
5. Squeeze trigger gun open to relieve system pressure.
6. Depress gas control knob slightly and turn to OFF position.
7. Turn off main shut-off valve on gas supply.

Storage Instructions

DANGER: Do not store flammable liquids (gasoline, diesel fuel, petroleum, solvents, etc.) near pressure washer, or in non-ventilated areas.

DANGER: Ne pas entreposer de liquides inflammables (essence, mazout, pétrole, solvants, etc.) à proximité de la laveuse à pression ou dans des endroits non ventilés.

IMPORTANT: Machine must be stored indoors.

OPERATIONS

⚠ WARNING: Protect from freezing by storing in a heated area, or by flushing the system with antifreeze (use an automotive engine antifreeze or windshield washer solvent to antifreeze).

AVERTISSEMENT : Protéger du gel en stockant dans un endroit chauffé ou en rinçant le système avec de l'antigel (utiliser un antigel pour moteur automobile ou un solvant pour lave-glace pour antigel).

To flush the system fill the float tank with antifreeze and remove pressure nozzle from wand. Start the machine and allow it to run until antifreeze runs from the end of the wand. Place wand into float tank and circulate the solution through system for several minutes. Open and close the trigger gun several times to circulate antifreeze through the unloader valve system. Also draw antifreeze through

the detergent inlet line to antifreeze the detergent system. For added protection after anti-freezing, disconnect the pressure hose from machine and remove the coil drain plug (refer to Component Identification illustration for location). After coil has drained, replace pressure hose and coil drain plug. If the pressure washer is not to be used for an extended length of time, it is recommended that the system be flushed with antifreeze for rust protection.

WARNING: Unauthorized machine modification or use of non-approved replacement parts may cause personal injury and/or property damage and will void the manufacturer warranty.

AVERTISSEMENT: Une modification non autorisée de la machine ou l'utilisation de pièces de rechange non approuvées peut causer des lésions corporelles et/ou des dommages à la propriété, et annulera la garantie du fabricant.

MAINTENANCE

Pump

Use Hotsy Pump Oil (8.923-422.0) 10W-40 for pump crankcase. Crankcase must be filled to the full mark on the dipstick or to center of sight glass window found on the rear of the pump. During the break-in-period, make sure the oil is changed after the first 50 hours of operation. After that, replace oil every year or 500 hours of operation, whichever comes first.

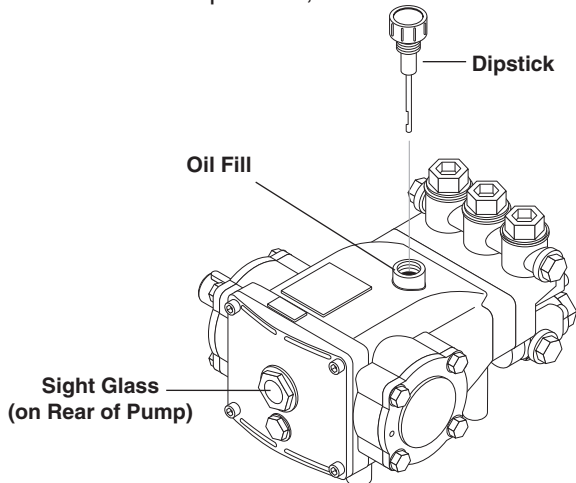

Proper Pump Care

- Do not pump acids.
- Do not allow pump to run dry.
- Winterize if storing in freezing temperatures; refer to Storage for details.
- Use a water softener on the water system if known to be high in mineral content.
- Use only high quality detergents and follow manufacturer's mix recommendations.
- Flush the system with clear water immediately

after using detergent solutions.

- Clean filter screen on detergent inlet line periodically.
- Flush the pressure washer system with antifreeze if storing for an extended period of time; refer to Storage for details.

Pump Motor

On a yearly basis, oil pump motor per instructions on motor nameplate.

NOTE: Some motors may be equipped with permanently lubricated bearings and will not require additional lubrication.

Gas Burner

It is recommended that the gas burner be serviced yearly or as needed. Contact your local service center.

Relief Valve

Each machine is equipped with a relief valve to relieve pressure in the system when higher than normal operating pressures are encountered or if the unloader valve should fail. Unusually high pressures come from an object plugging the spray nozzle. If operating pressure is found to be normal and the relief valve continues to leak, repair or replace valve. The Safety Relief Valve should be opened to release any sediment yearly. Start the pressure washer and use an Allen wrench to turn the pressure relief valve counter clockwise until water is pouring out the valve. Then turn the adjustment nut/bolt until the valve stops leaking. Open and close the trigger gun and if water squirts out the valve when you close the trigger gun turn clockwise one full turn until there is no leaking when the trigger gun is closed.

MAINTENANCE

Unloader Valve

WARNING: The unloader valve on this pressure washer has been factory set and sealed and is a field nonadjustable part. Tampering with the factory setting may cause personal injury and/or property damage, and will void the manufacturer warranty.

AVERTISSEMENT: La soupape de décompression sur cette laveuse à pression a été réglée en usine, puis scellée, et est une pièce non réglable. L'altération du paramètre de l'usine pourrait causer des lésions corporelles et/ou des dommages à la propriété, et annulera la garantie du fabricant.

Heating Coil

Coil Descaling: In hard water areas, scale buildup within the heating coil will occur. Scale deposits will decrease the water temperature rise and may eventually clog the heating coil. Contact your local service center when descaling is needed.

Coil Desooting: Poor grades of fuel oil or inadequate combustion air will cause heavy soot buildup on the outside surface of the heating coil. These deposits will insulate the coil. This will restrict the air flow through the coil, further aggravating the soot buildup. Contact your local service center when desooting is needed.

Smart Relay Instructions

Digital Timer (Optional)

The following are instructions on how to set the parameters on the digital timer in Programming Mode. To define these settings please follow the steps below.

Setting the Clock:

1. Press the ESC key located next to the display window and under the arrow key pad (see figure below). Pressing the ESC key will access the Parameter Assignment Menu.

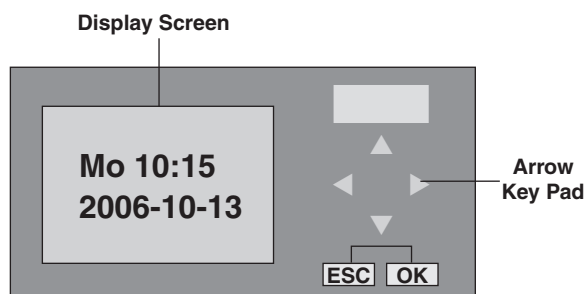

Stop
Program
Setup
Network
Diagnostics

2. Using the up/down arrow keys ▲ or ▼, move the cursor to highlight 'Setup' and press OK to accept.

Msg Config
Start Screen
Clock
LCD
Menu Language
Switch to OP

3. Move the cursor to highlight 'Clock' and press OK to accept.

NTP
Set Clock
S/W Time

4. Move the cursor to highlight 'Set Clock' and press OK to accept.

Set Clock
Mon. 10:15
YYYY-MM-DD

NOTE: When setting time on clock, use only military time.

5. Move the cursor to the value wanting to be changed using the left/right arrow keys t or u, and change the value by using the up/down arrow keys s or t. When you are done setting the time

and date press OK to accept your changes.

6. Press ESC three times to exit to the main menu.

Programming Instructions

The 900/1400 can be configured to run in Time Delay or Auto Start/Stop with lockout. Machines are factory set with Auto Start/Stop with 4 hour Lockout. A Smart Relay controls how the machine will operate by using three internal timers; these timers are adjustable. The following is a brief description of these timers:

Timer 1: 'Lockout Timer' (Time Delay)

- Timer 1 de-energizes (lockout) the machine if not being used for a preset time. If machine has 'Locked out' it can only be re-energized by pressing the 'Pump On' switch. Timer 1 is factory set to 4 hours.

Timer 2: 'Auto Start/Stop Timer'

- Timer 2 allows the pump to run in bypass for a preset time. If the pump runs in bypass longer than the allotted time the timer will drop power

MAINTENANCE

to the motor contactor and machine will be in standby mode. Squeezing the gun trigger will restart the pump (if Timer 1 has not locked out). Timer 2 is factory set to 30 seconds.

Timer 3: 'Reset Delay Timer'

- Timer 3 controls how long the pump must run before resetting the 'Lockout Timer' (Timer 1). This allows the pump to run long enough to re-pressurize the system if there is pressure loss when not in use. Timer 3 is factory set to 15 seconds.

To change to the parameters of the internal timers in the Smart Relay complete the following steps:

1. Turn on the power to the machine but do not press the start switch. Remove the front panel and then the control panel cover. Note: Use extreme caution when reaching into the control box, the machine has live power. Once powered the Smart Relay window will display the following screen, see figure 1 (if screen does not appear press the left/right arrow keys ◀ or ▶ until correct screen appears).

Display Screen

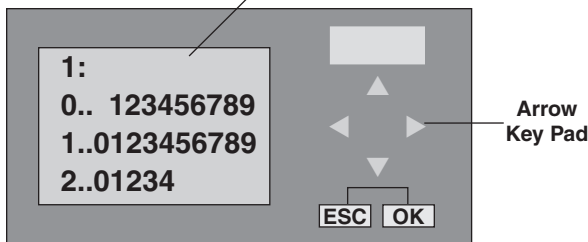

Fig. 1

2. Press the ESC key located next to the display window and under the arrow key pad to access the Menu.

Stop
Program
 Setup
 Network
 Diagnostics

3. Using the up/down arrow key ▲ or ▼, move the cursor to highlight 'Program' and press OK to confirm.

Set Parameter
 Prog Name

4. Using the up/down arrow key ▲ or ▼, move the cursor to highlight 'Set Parameter' and press OK to confirm.

Timer-1
 Timer-2
 Timer-3

5. The display window will display the Timers. Highlight the Timer desired to change and press OK.

NOTE: Ta is the accumulator timer and T is the adjustable timer (the variable that changes).

Timer-1 1/1
 T= 04:00h
 Ta= 00:00

6. Highlight the T field and press OK to edit the value. Use the left/right arrow keys t or u, move the cursor to the used the up/down arrow keys ▲ or ▼ to change this value. Each timer has optional units of time in seconds (s), minutes (m), and hours (h). To change the unit of time using the arrows up/down keys ▲ or ▼. Once all values have been set press, OK to accept and ESC to back up to the Timer selection menu.

Repeat steps 5 and 6 for the other times if needed. When finished press ESC three times to go to the main menu.

MAINTENANCE

Factory Set Parameters (Auto Start/Stop with Lockout)

TIMER	VALUE	DESCRIPTION
Timer 1	04:00 Hours	Turns machine off after 4 hours of non-use. To restart push the 'Pump On' switch.
Timer 2	30:00 Seconds	Pump will run in bypass for 30 seconds before shutting off, machine is still in standby mode. Pulling the gun trigger will restart the pump.
Timer 3	15:00 Seconds	In case of pressure loss when machine is in standby, the pump can run up to 15 seconds before resetting 'Timer 1' (lockout)

Time Delay Parameters

TIMER	VALUE	DESCRIPTION
Timer 1	04:00 Hours	When machine is not in use, pump will run in bypass for 3 minutes and shut off. To restart push the 'Pump On' switch.
Timer 2	30:00 Seconds	To operate in time delay mode timer 2 must be deactivated. This is done by setting timer 2 to value greater than timer 1.
Timer 3	15:00 Seconds	Pump must run more than 15 seconds to reset timer 1.

Preventative Maintenance	
Pressure Relief Valve	Open annually to remove any sediment.

MAINTENANCE

Optional — Water Inlet Solenoid

A water inlet solenoid can be added to the machine that will open only when the machine is running or in standby. The solenoid closes when the machine is off to prevent possible water overflow when unattended.

Installation

- Connect a 24V/AC normally closed solenoid on the water inlet, contact local Hotsy dealer for solenoid options.
- Connect solenoid to the remote terminal using 16 ga minimum wire
- Wire solenoid to remote terminal according to figure below

Before powering up machine, fill float tank to prime the system.

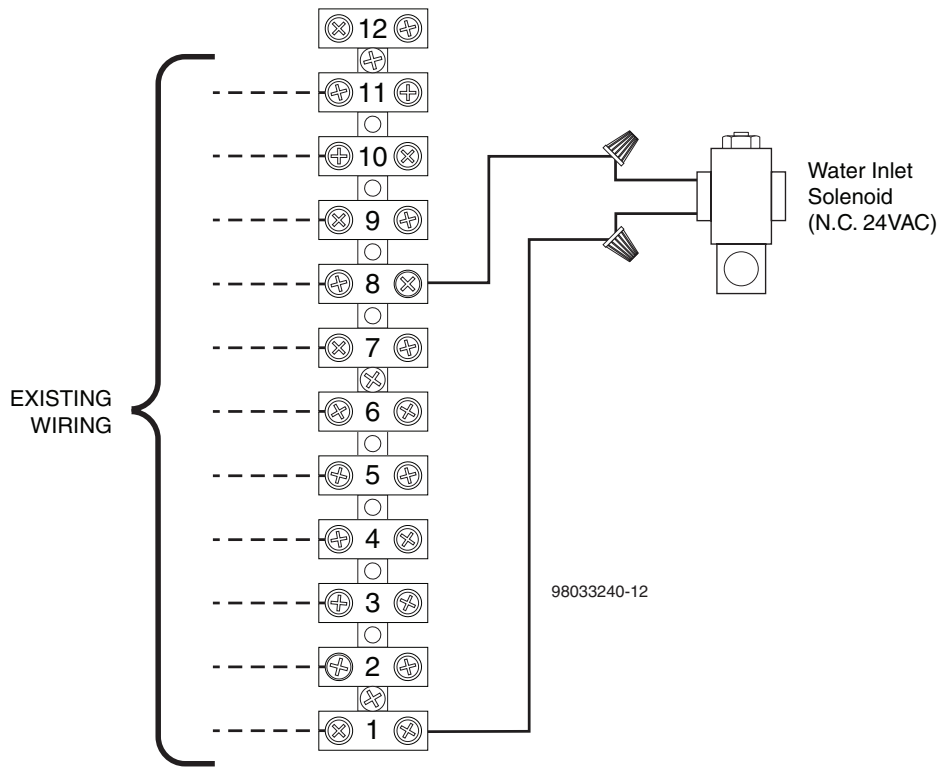

Water Inlet Solenoid Wiring Schematic
(Remote Terminal Located Inside Machine)

Water Inlet Solenoid Wiring Schematic

MAINTENANCE

Troubleshooting

SYMPTOMS	POSSIBLE CAUSES	CORRECTIVE ACTION
PRESSURE WASHER WILL NOT RUN	Pump switch in OFF position	Place switch in ON position.
	Power supply disconnected	Connect power supply.
	Fuse blown or circuit breaker tripped in electrical supply line	Replace fuse or reset circuit breaker. Use only circuits of adequate capacity.
	Motor circuit overload tripped	Allow sufficient time for motor to cool down. Place pump switch in ON position.
PRESSURE WASHER RUNS BUT WON'T SPRAY	Trigger of trigger gun released	Squeeze trigger.
	Water supply not turned on	Open water supply valve.
	Clogged pressure nozzle	Clean pressure nozzle opening.
	Inlet water screen clogged	Check screen and clean if necessary.
	Pump sucking air	Fill the detergent container and check for loose hose clamps or fittings.
LOW SPRAY PRESSURE AT NOZZLE	Inadequate water supply	Fully open faucet. Check for kinked or damaged hose. Use 5/8" minimum hose. Check for debris clogging inlet screen.
	Partially clogged or damaged pressure nozzle	Clean or replace.
	Air being drawn through detergent inlet line	Refill detergent container. Ensure that pick-up screen is fully immersed.
UNEVEN SPRAY PATTERN	Partially clogged or damaged pressure nozzle	Clean or replace.
PRESSURE WASHER WILL NOT PRODUCE HOT WATER	Burner switch in OFF position	Place switch in ON position.
	Gas valve switch in OFF position	Place switch in ON position.
	Inadequate fuel supply	Check fuel supply.
	Pump switch turned off	Pump must be running before burner will light.
PRESSURE WASHER WILL NOT PRODUCE HOT WATER (CONTINUED)	Inadequate water supply	Fully open faucet. Check for kinked or damaged hose. Use 5/8" minimum hose. Check for debris clogging inlet screen.
	Trigger of trigger gun released	Squeeze trigger. Water must be spraying for burner to light.
	Thermostat set too low, or defective	Raise thermostat setting. Replace if defective.
	Manual gas valve not open	Turn ON gas valve.
	Defective gas valve	Replace gas valve.

MAINTENANCE

Troubleshooting

SYMPTOMS	POSSIBLE CAUSES	CORRECTIVE ACTION
POOR OR NO DETERGENT FLOW	Inadequate detergent supply	Refill detergent container. Ensure that pick-up screen is fully immersed.
	Detergent screen or hose clogged	Clean. Always start with a clean detergent container.
	Clogged detergent injector check valve	Clean check valve at detergent injector.
POOR CLEANING	Improper detergent concentration or mixing	Mix detergent per manufacturer's instructions. Ensure that powdered detergents are fully dissolved.
	Wrong detergent for the application	Select appropriate detergent.
	Rinsing with hot water	A final rinse with cold water will reduce water spotting.
	Detergent valve not opening	Check that handle or knob is not slipping on shaft.
UNLOADER CYCLES WHEN TRIGGER GUN IS OPENED OR CLOSED	Air in system	Open and close trigger gun several times.
	Unloader defective	Replace if defective.
	Water leak between unloader valve and trigger gun	Check fittings, hose and trigger gun for leaks. Repair or replace.
BURNER SMOKES OR HAS OBNOXIOUS ODOR	Stack restriction	See Venting under Installation.
PRESSURE RELIEF VALVE LEAKING	Excessive pressure due to defective unloader valve	Replace unloader valve.
	Defective relief valve	Replace relief valve.
	Dirty relief valve	Clean relief valve seat

MAINTENANCE

Burner Troubleshooting

PROBLEM	POSSIBLE CAUSE	SOLUTIONS
HAVE PILOT FLAME, MAIN BURNER WILL NOT TURN ON	Faulty main valve coil in the gas valve	Set test meter to 24 volt scale.
	Faulty igniter/sensor and/or its wiring	With pilot flame on igniter/sensor, probe terminals MV and MV/PV on the ignition control unit. If you read 24 volts here, but not at the gas valve, there is a loose wiring connection. Repair or replace as needed.
	Ground wire not attached to machine chassis	If you do read 24 volts at MV and MV/PV and the pilot flame is impinging on the igniter/sensor rod, the problems may be:
	Faulty ignition control unit	a. Faulty igniter/sensor and/or its wiring.
		b. Faulty ignition control unit.
		Set test meter to the ohm scale. Turn burner switch off.
		Check continuity through the green ground wire and its connections.
Reconnect the igniter/sensor wire and the ground wire.		
Turn burner switch on. With the pilot burning and the flame on the igniter/sensor rod, the main burner should turn on. If it does not, replace the ignition control unit.		
SHORT-CYCLING OF MAIN BURNER. MAIN BURNER TURNS OFF BEFORE THE BURNER SWITCH OR FLOW SWITCH IS TURNED OFF	Draft condition pulls flame from igniter/sensor rod.	Check the thermostat by bypassing at terminals P1 & 1.
		Set thermostat high. With main burner on, observe the pilot flame impingement on the igniter/sensor.
	Faulty thermostat or water temperature is too high	If pilot flame is small and draft condition pulls flame from igniter sensor rod, the burner will turn off and then on again. a. Adjust pilot flame higher or clean pilot orifice. b. Bend igniter/sensor rod closer to pilot flame.
		If flame impingement on the igniter/sensor is stable and the system short-cycles, check the limit switch.
		Set test meter to 110 volt scale; a. When the system cycles off, probe the switch terminals of the limit switch. b. If you read 24V across the switch terminals the limit switch is open. Replace the limit switch.
A pilot flame set too high will also cause burner to short cycle. Pilot flame lifts over igniter/sensor.		

MAINTENANCE

Burner Troubleshooting

PROBLEM	POSSIBLE CAUSE	SOLUTIONS
FLOW & BURNER SWITCH ON; NO SPARK, NO PILOT GAS	A. No main power	With power switch on, open trigger on spray gun and set your test meter to the 24 volt scale. Probe terminals 24V and 24V(GND). If you do not read 24 volts, the problem is not the ignition system. Perform normal system checks of main power, transformer, thermostat and the limit control. If you do read 24 volts at TH and GND, the problem is in the ignition system. Check for loose or defective wiring. If wiring is good, replace the ignition control unit.
	B. Faulty transformer	
	C. Faulty burner & flow switch	
	D. Faulty ignition control unit	
HAVE SPARK, NO PILOT GAS FLOW	Main gas supply turned off	Set test meter to 24 volt scale.
		1. Be sure main gas valve (gas cock or selector arm) is turned on.
		2. With gas on and system sparking, probe terminals PV and 24V(GND). If pilot gas does not flow with 24 volts at these terminals, replace gas valve.
		3. Probe terminals PV and MV/PV. If 24 volts not present, replace ignition control box.
HAVE PILOT GAS, NO SPARK	A. Defective igniter/sensor and or its wiring	Set test meter to ohm scale.
		1. Disconnect the wire from the IGN terminal on the ignition control unit.
	B. Faulty ignition control unit	2. Touch one meter probe to the tip of the igniter/sensor rod in the pilot. Touch the other probe to the quick connect at the other end of igniter/sensor wire.
		3. If you have continuity from the tip of the igniter/sensor rod to the connector and no spark, replace the ignition control unit.
		4. If you do not have continuity through wire and the igniter/sensor, check for a loose wire connection in the wire. Repair as needed.
		5. Check to see if spark shorts to burner ring through a cut in the igniter wire.

MAINTENANCE

IMPORTANT

If the pressure washer demonstrates other symptoms or the corrective actions listed do not correct the problem, contact the local authorized Hotsy Service Center. The Hotsy Service Center can be identified by visiting www.hotsy.com.

When ordering from your dealer, please provide the following:

Model Number: _____ **Release:** _____

Machine Serial Number: _____

Component Part Number: _____

Description: _____

GAS-FIRED SERIES OPTIONAL EQUIPMENT

8.717-728.0 Draft Diverter, 8"

If you need **SERVICE** on your pressure washer, contact your local Hotsy dealer or visit www.Hotsy.com. Smart phone users scan the code below to link directly to the Service Request page.



To **REGISTER** your pressure washer, please visit our Warranty Registration page at www.hotsy.com/WarrantyRegistration.aspx or scan the code below with your smart phone.



9.802-199.0 - Printed in U.S.A.