

High Pressure Gun

HP 1500S-V-E-24V

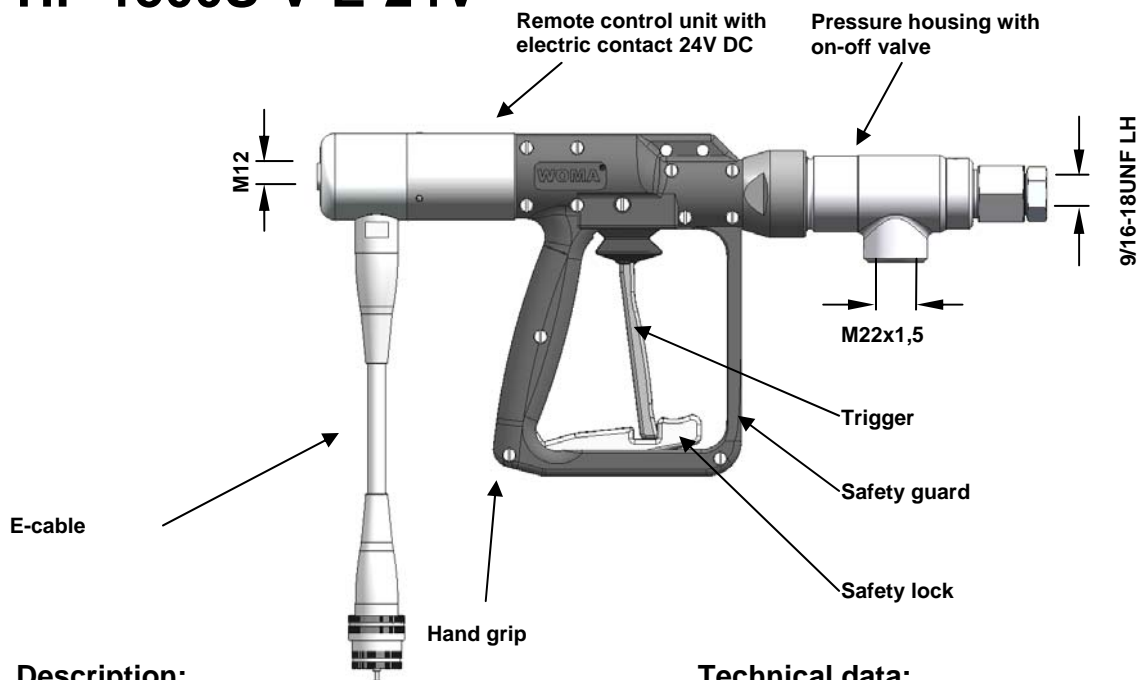

Description:

The HP 1500S-V-E-24V is a positive shutoff type high pressure jetting gun which incorporates an internal on/off valve and low voltage micro switch into its design.

Via the micro switch the high-pressure operation of the unit can be switched on or off. This facilitates work and increases worker safety.

Standard equipment includes: A trigger safety guard and latching trigger lock to prevent unintentional use, forged steel pressure housing and light weight polymerized hand grip.

Advantages:

High safety standard

Turnable hand grip for easy operation

Full encapsulated polymerized hand grip offers high tensile strength and excellent resistant to most chemicals.

All functional parts are protected from dirt and water invasion.

Technical data:

Material-No.:	9.871-328.0
Operating pressure:	max. 1500 bar
Medium temperature:	max. +100°C
Recoil force perm. without body support:	max. 150 N
Recoil force perm. with body support:	max. 250 N
Pressure loss:	5 bar at 30 l/min
Weight:	appr. 3,0 kg
Length:	appr. 460 mm
Height:	appr. 196 mm
Width:	appr. 72 mm

HP 1500S-V-E-24V – Components

Nozzle connection	
Material No.	Nozzle form
9.873-090.0	1 and 8
9.872-008.0	4 and 19
9.878-291.0	21

Nozzle connection for nozzle form 4
for coherent jet forming
Mat.-No.: 9.872-183.0

Orbimaster

Turbo nozzle

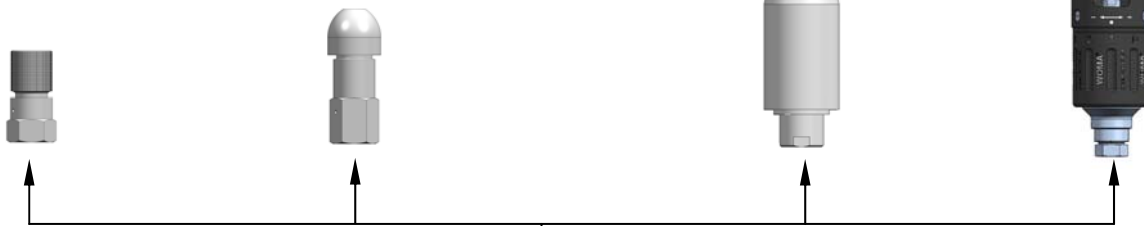

Nozzle pipe		Weight
Material No.	L (mm)	kg
9.891-181.0	300	0,26
9.891-182.0	500	0,43
9.891-183.0	750	0,64
9.891-184.0	1000	0,85
9.891-207.0	1500	1,30
9.891-185.0	2000	1,69
9.891-186.0	3000	2,53
9.891-187.0	4000	3,37
9.891-188.0	5000	4,21
9.891-189.0	6000	5,05
9.891-383.0	7000	5,89

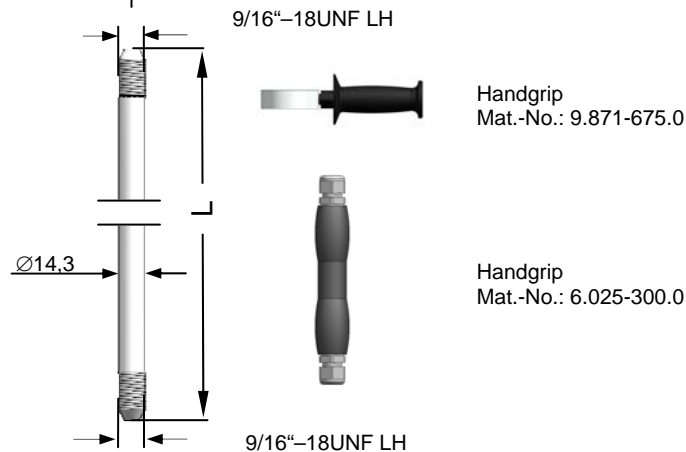

Gun housing cpl. HP 1500S-V-24V
Mat.-No.: 9.871-328.0
Weight: appr. 3,0 kg

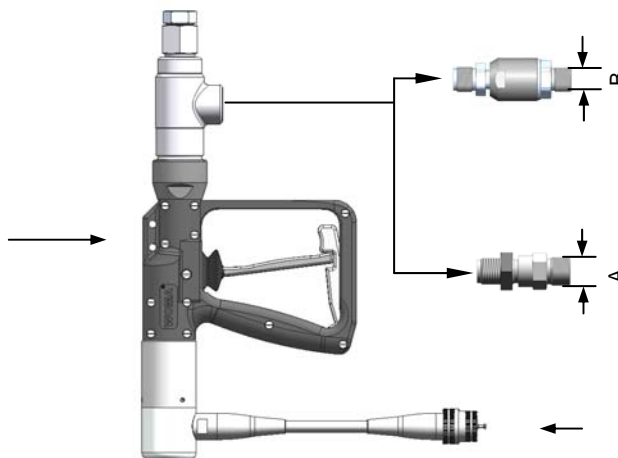

Turnable hose connection	
Material No.	B
9.872-624.0	M22x1,5 24° DK
9.872-436.0	M22x1,5 60° DK
9.872-437.0	M24x1,5 24° DK
9.872-438.0	G1/2 60° DK

Hose connectionr	
Material No.	A
9.871-967.0	M22x1,5 24° DK
9.871-968.0	M22x1,5 60° DK
9.871-969.0	M24x1,5 24° DK
9.871-970.0	G1/2 A 60° DK
9.871-971.0	G3/4 A 60° DK

E-cable 300 mm long
Electric connection 24V DC

Body support
Mat.-No.: 6.025-301.0
Weight: appr. 0,73 kg

