

Höchstdruckschlauch

Very high pressure hose



DN 12 – HST4G – SR3

Betriebsdruck	:	max.	1100 bar	Aufbau :
Operating pressure	:	max.	15950 psi	Schlauchseele aus synthetischem Gummi
Prüfdruck	:		1650 bar	Druckträger aus vier Draht-Spirallagen.
Test pressure	:		23925 psi	Oberdecke aus synthetischem Gummi
				Temperaturbereich: -10°C bis +80°C

Verwendung für : alle WOMA Produkte
To use for : all WOMA products

Construction :

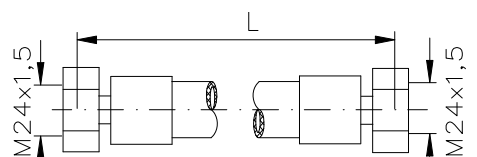
Synthetic rubber inner tube
4 spiralwire reinforcement
Synthetic rubber cover
Operating temperature range: -10°C to +80°C

Schlauchleitungen Hose tubes				Schlauchmeterware Hose per metre					
									
Material-Nr. Material-No.	Nennlänge Nominal length L = m	Gewicht Weight kg	Einbindung mit Armaturen Equipped with fittings Werkstoff/Material	Material-Nr. Material-No.	Innen-φ Inner-φ φ i mm	Außen-φ Outer-φ φ a mm	Biegeradius Bendradius R = mm	Gewicht Weight kg/m	max. Lieferlänge max. delivery length m
9.887-887.0	10	14,9	Stahl / Steel	9.887-890.0	12,7	27,0	250	1,39	40
9.887-888.0	20	28,8	Stahl / Steel						
9.887-889.0	40	56,6	Stahl / Steel						

Gewinde M nach DIN 13 / ISO 261; thread M as per DIN 13 / ISO 261

Schlaucharmaturen und Zubehör

Hose fittings and accessories

DN 12 – HST4G – SR3

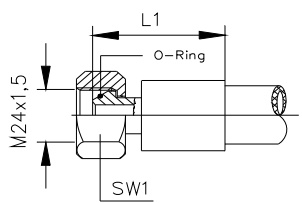
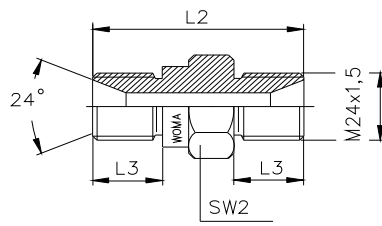
Überwurfarmatur Swivel fitting					Schlauchverbinder Hose connector				
									
Material-Nr. Material-No.	Werkstoff Material	L 1 mm	SW 1 Width across flats mm	O-Ring Material-Nr. Material-No.	Teile-Nr. Part-No.	L 2 mm	L 3 mm	SW 2 mm	Werkstoff Material
9.887-891.0	Stahl / Steel	110	30	6.025-315.0	9.877-911.0	65	20	32	NIRO / SS

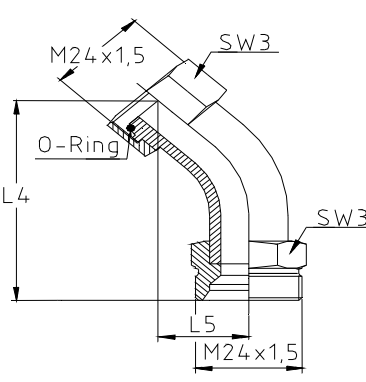
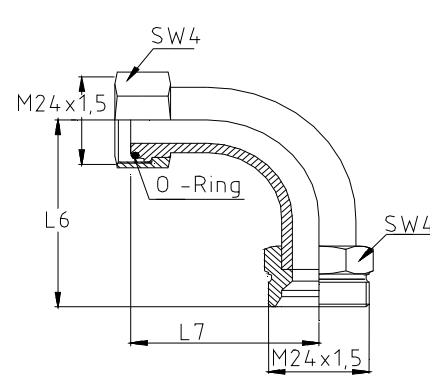
45° Rohrkrümmer 45° Elbow						90° Rohrkrümmer 90° Elbow					
											
Material-Nr. Material-No.	Werkstoff Material	L 4 mm	L 5 mm	SW 3 mm	O-Ring Material-Nr. Material-No.	Material-Nr. Material-No.	Werkstoff Material	L 6 mm	L 7 mm	SW 4 mm	O-Ring Material-Nr. Material-No.
9.887-325.0	Stahl / Steel	100	43	30	9.882-191.0	9.887-324.0	Stahl / Steel	77	76	30	9.882-191.0
						9.888-507.0	NIRO / SS	96	64	30	

Gewinde M nach DIN 13 / ISO 261; thread M as per DIN 13 / ISO 261

NIRO = nichtrostender Stahl, SS = Stainless Steel