

<b>1</b>	<b>GENERAL .....</b>	<b>3</b>
<b>2</b>	<b>SCOPE.....</b>	<b>3</b>
<b>3</b>	<b>PURPOSE .....</b>	<b>3</b>
<b>4</b>	<b>NOTES.....</b>	<b>3</b>
4.1	IMPORTANT STANDARDS FOR SAFETY TESTING.....	3
4.2	DEFINITIONS .....	4
4.3	PROTECTIVE CLASSES.....	4
<b>5</b>	<b>TYPES OF TESTS .....</b>	<b>4</b>
5.1	INDIVIDUAL TESTS .....	4
5.2	PROTECTIVE CONDUCTOR TESTING (PE).....	5
5.3	INSULATION TESTING (ISO) .....	6
5.4	HIGH-VOLTAGE TESTING (HV TEST) .....	6
5.4.1	<i>Test voltages for AC testing (testing with AC current, approx. 50 HZ) .....</i>	<i>6</i>
5.4.2	<i>Test voltages for DC testing (testing with DC current, approx. 5 HZ) .....</i>	<i>7</i>
5.4.3	<i>High voltage thermal test .....</i>	<i>7</i>
5.4.4	<i>HV test on electrical motors .....</i>	<i>7</i>
5.4.5	<i>High voltage test on battery chargers.....</i>	<i>8</i>
5.4.6	<i>HV testing on equipment with PRCD-K protect switch.....</i>	<i>8</i>
<b>6</b>	<b>LAYOUT OF THE TEST BENCHES.....</b>	<b>8</b>
6.1	AREA OF APPLICATION .....	8
6.2	LAYOUT OF A TEST BENCH (ACCORDING TO EN 50191).....	9
6.2.1	<i>Cordoning off the test area .....</i>	<i>9</i>
6.2.2	<i>Signal lamps and markings .....</i>	<i>9</i>
6.2.3	<i>Emergency-stop mechanism.....</i>	<i>9</i>
6.3	OPERATING TEST BENCHES.....	9
6.3.1	<i>General .....</i>	<i>9</i>
6.3.2	<i>Personnel.....</i>	<i>9</i>
<b>7</b>	<b>TEST PROCEDURES.....</b>	<b>10</b>
7.1	DAILY INSPECTION OF TEST UNITS .....	10
7.2	APPLIANCE TESTING .....	10
7.2.1	<i>Preparation.....</i>	<i>10</i>
7.2.2	<i>Conducting the protective conductor and insulation tests according to EN 60204.....</i>	<i>10</i>
7.2.3	<i>Conducting protective conductor test according to EN 50106.....</i>	<i>11</i>
7.2.4	<i>Conducting high voltage test.....</i>	<i>11</i>
7.2.5	<i>Conducting high voltage tests on switch-boards .....</i>	<i>12</i>
<b>8</b>	<b>MARKING TESTED DEVICES.....</b>	<b>12</b>
8.1	APPLIANCES WITH TEST RESULTS "HV GOOD" .....	12
8.2	APPLIANCES WITH TEST RESULTS "HV POOR" .....	12
8.2.1	<i>Defective appliances during functional testing.....</i>	<i>13</i>
<b>9</b>	<b>CALIBRATION.....</b>	<b>13</b>
9.1	TEST UNIT.....	13

ACHTUNG! Ein Ausdruck dient nur zur Information! Die aktuelle Version ist im Kärcher-Inside hinterlegt.

Ersetzt Ausgabe vom:	2014-07-18	Erstellt:	OQM / Elliott	Freigabe:	OQM / Stütz
Ausgabedatum:	2018-02-15	Geprüft:	OQD-L / OQM	Seite 1 von 16	

9.2	TEST DUMMY .....	13
10	TRAINING FOR SAFETY INSPECTORS .....	13
11	PROCESS DESCRIPTION .....	14
11.1	TESTING FLOW .....	14
11.2	FLOW WHEN ERRORS AT FUNCTION TEST BENCH .....	15
12	REFERENCE .....	16
13	MODIFICATIONS .....	16

*ACHTUNG! Ein Ausdruck dient nur zur Information! Die aktuelle Version ist im Kärcher-Inside hinterlegt.*

Ersetzt Ausgabe vom:	2014-07-18	Erstellt:	OQM / Elliott	Freigabe:	OQM / Stütz
Ausgabedatum:	2018-02-15	Geprüft:	OQD-L / OQM	Seite 2 von 16	

	<h1>IM-Procedure</h1>	
	<h2>Electrical Safety Testing</h2>	<b>06-B07e</b>

### 1 General

Summarized the changes to the previous version:

- a.) Add chapter 'General' and chapter 2 'Scope'
- b.) The former chapter 1 has been split into chapter 3 ' Purpose' and 4 ' Notes'
- c.) The note to the DIN 60204 was changed and the determinations for Kärcher have been added in chapter 5.2
- d.) Replacement of process description into chart format description (chapter 11)
- e.) New Kärcher logo
- f.) Add new chapter 12 'References)

### 2 Scope

The scope includes the whole Kärcher Group.

### 3 Purpose

Electrical safety testing has to be done to protect the user of electrical appliances against dangers from defects in the electrical part. We carry out individual testing during the production, i.e. each appliance has to be subjected to electrical safety testing. The EN standards EN 60335 respectively EN 50106 as well as EN 60 204 form the basis of electrical safety testing.

The applicable standards can be found in the current FKV of the appliance to be tested. FKV = "Fertigungs- und Kontrollvorschrift" in German, "Instruction for Manufacturing and Inspection" in English.

### 4 Notes

#### 4.1 Important standards for safety testing

**EN 60335:** Safety of electrical household appliances and similar devices.

**EN 50106:** Special rules for individual testing of appliances in the area of application of EN 60335.

**EN 60204:** Electrical equipment of machines.

**EN 50191:** Setting up and operating stationary and mobile electrical testing units.

**Appliances produced for USA and Canada has to be tested according to the following testing standards:**

**UL 1776:** Standard for high-pressure cleaner

**UL 1017:** Standard for vacuum cleaner

**UL 499:** Standard for steam cleaner

<i>ACHTUNG! Ein Ausdruck dient nur zur Information! Die aktuelle Version ist im Kärcher-Inside hinterlegt.</i>		
Ersetzt Ausgabe vom:	2014-07-18	Erstellt: OQM / Elliott
Ausgabedatum:	2018-02-15	Geprüft: OQD-L / OQM
		Freigabe: OQM / Stütz
		Seite 3 von 16

	<h1>IM-Procedure</h1>	
	<h2>Electrical Safety Testing</h2>	<b>06-B07e</b>

## 4.2 Definitions

According to **EN 60335 Part 1**:

### Basic insulation:

The insulation of parts subjected to voltage for providing them basic protection against electrical shocks (e.g. insulation of individual wires of a cable).

### Small safety voltage:

Voltage, whose nominal value between two conductors or between a conductor and neutral conductor, does not exceed 42 Volts. The open-circuit voltage should not exceed 50 Volts.

### Double insulation:

Insulation consisting of basic insulation and additional insulation.

## 4.3 Protective classes

**Device of protective class I** (short: SK I) is an appliance, where protection against electrical shocks is not solely dependent on the basic insulation; but all metal parts that come into contact are connected to the protective conductor system of the power supply in such a way that no dangerous touching potential is generated when the basic insulation fails.

**Device of protective class II** (SK II) is an appliance where protection against electrical shocks is ensured through the basic insulation and an additional double or increased insulation. No protective conductors provided. The structure and quality of the power supply network does not have any effect on the safety of such appliances.

**Device of protective class III** (SK III) is an appliance, where protection against electrical shock is ensured by using safety low-voltage. This has to be generated through a safety transformer or a battery. The safety low-voltage should not exceed 42 V; in case of floor cleaners (EN 60335-2-72), max. 48 V if the battery poles are covered.

## 5 Types of tests

Tests are meant to prove that the appliances are totally safe for the user or the environment provided if used properly or mishandled to known extent.

We distinguish between type testing and individual testing.

All the tests described in part 1 of EN 60335 are part of type testing.

Individual testing procedures are described in EN 50106, EN 60204 respectively in the corresponding UL standards.

### 5.1 Individual tests

These tests have to be conducted by the manufacturer on each appliance after soon its production has been completed. They are meant to cover unacceptable changes in the materials or production processes from a safety point of view. Generally, the manufacturer is expected to carry out additional tests based on his experience (for e.g. an audit or repeated type testing).

<i>ACHTUNG! Ein Ausdruck dient nur zur Information! Die aktuelle Version ist im Kärcher-Inside hinterlegt.</i>		
Ersetzt Ausgabe vom:	2014-07-18	Erstellt: OQM / Elliott
Ausgabedatum:	2018-02-15	Geprüft: OQD-L / OQM
		Freigabe: OQM / Stütz
		Seite 4 von 16

The following individual tests are required:

## 5.2 Protective conductor testing (PE)

The protective conductor test checks the conductivity and the correct fixed connection of the protective conductor. For this purpose, it is necessary to do a visual inspection according to EN 60335-1 Section 27 along with a manual sample (draw test) at the connection point of the protective conductor. During electrical testing a current of min.10 A is passed via the protective contact to all touchable metal parts from a current source with an open-circuit voltage of max. 12 volts. The fall in voltage is measured and the resistance is calculated with this and the current flow. The tests are done at  $20\text{ °C} \pm 5\text{ °C}$ . The limiting values are:

According to EN 50106

$R < 0.2\text{ Ohm}$  for appliances with a non-detachable connection;

$R < 0.1\text{ Ohm}$  for all other appliances.

In case of devices with long power cords, the resistance may exceed 0.2 Ohm; however, it must not be greater than the sum of the resistance of the power cord + 0.1 Ohm.

According to EN 60204

The measured resistance has to be in a range according to their length, profile and material of the expected protective conductor.

Determination Kärcher: Test according to EN 50106. Means here  $R < 0.2\text{ Ohm}$

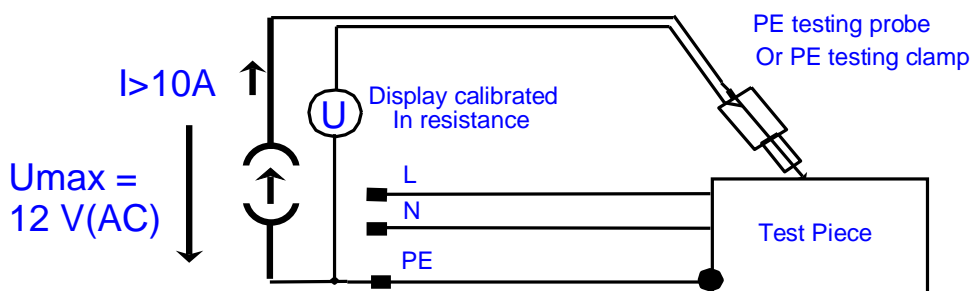

Appliances equipped with a PRCD-K protect switch (e.g. vacuum cleaner at fire departments) have to get their electrical safety testing done with a PRCD-K protect switch and with the appliance.

The PRCD-K protect switch is an all-pole switching differential current circuit breaker with low voltage circuit breaker and protective conductor monitoring, with a varistor in the protective conductor path.

That's why a PE test with a protect switch is not possible (high electrical resistance). The PE current path has to be externally bypassed at the PRCD-K protect switch to conduct a PE test with the appliances and the feeder. (note: open protect switch and combine clip PE IN with PE OUT)

*ACHTUNG! Ein Ausdruck dient nur zur Information! Die aktuelle Version ist im Kärcher-Inside hinterlegt.*

Ersetzt Ausgabe vom:	2014-07-18	Erstellt:	OQM / Elliott	Freigabe:	OQM / Stütz
Ausgabedatum:	2018-02-15	Geprüft:	OQD-L / OQM	Seite 5 von 16	

### 5.3 Insulation testing (Iso)

This test is conducted only for devices that have to be tested according to EN 60204. The insulation resistance between the conductors (L1 to L3; N) and PE is measured. The measurement voltage is 500 Volts. The insulation resistance must be higher than  $10^6$  Ohm (1MOhm).

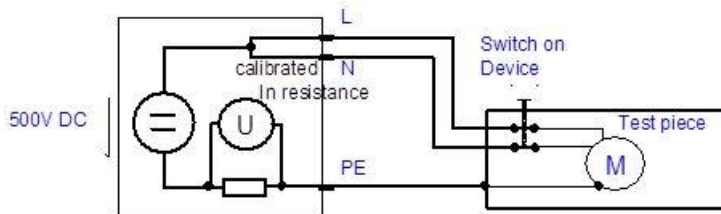

### 5.4 High-voltage testing (HV test)

A sinus-shaped voltage with a frequency of 50 Hz between PE and all short-circuited conductors (L1 to L3 and N) (in the test unit) and the value given in table 2.4.1 is applied for duration of 1 s.

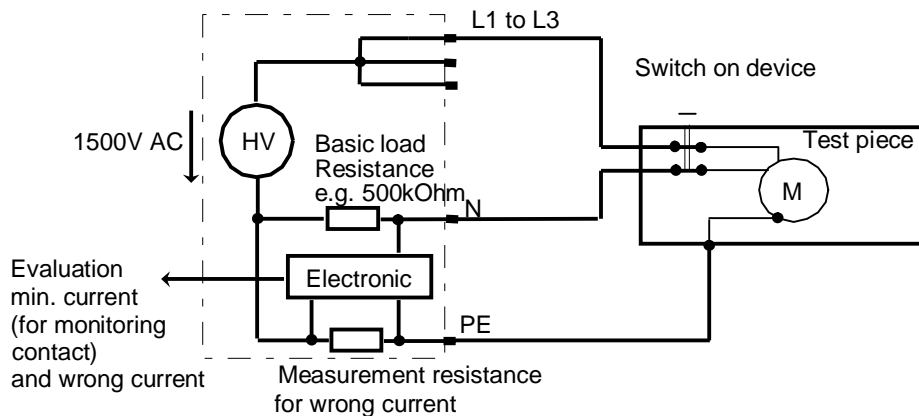

#### 5.4.1 Test voltages for AC testing (testing with AC current, approx. 50 HZ)

Test time 1 sec.

	Protection class I	Protection class II	Protection class III
<b>EN 50106</b>	1000 V	2500 V	400 V <sup>*3</sup>
<b>EN 60204</b>	1000 V	Not applicable	Not applicable
<b>UL / CSA</b>	$1200 + 2.4 \times U_{\text{nenn}}^{*2}$	$1200 + 2.4 \times U_{\text{nenn}}^{*2}$	Not applicable
<b>Kärcher commitment<sup>*1</sup></b>	<b>1500 V <sup>*2</sup></b>	<b>2500 V <sup>*2</sup></b>	<b>No testing <sup>*3</sup></b>

<sup>\*1</sup> to avoid failures during switching to a different voltage, Kärcher is testing with a standardized test voltage (1500 V AC for SK I, 2500 V AC for SKII), which covers all requirements described, besides exceptions <sup>\*2</sup> and <sup>\*3</sup>.

<sup>\*2</sup> the following is applicable for devices that are to be tested according to UL / CSA:

- $U_{\text{rated}} < 125$  V: Uniform testing with  $U=1500$  V AC at protection class I.

*ACHTUNG! Ein Ausdruck dient nur zur Information! Die aktuelle Version ist im Kärcher-Inside hinterlegt.*

Ersetzt Ausgabe vom:	2014-07-18	Erstellt:	OQM / Elliott	Freigabe:	OQM / Stütz
Ausgabedatum:	2018-02-15	Geprüft:	OQD-L / OQM	Seite 6 von 16	

- $U_{\text{rated}} > 125 \text{ V}$ : AC testing with  $U = (1200 + 2.4 \times U_{\text{rated}})$ . Test voltage at least 1500 V AC at protection class I and 2500 V AC at protection class II.
  - Body-held devices (e.g. back cleaner) are tested with 3000 V AC.
- <sup>\*3</sup> It is necessary to conduct HV testing if  $U > 42 \text{ V}$  (or 48 V in case of floor cleaners).

### The tripping current should not exceed 5mA.

The tripping current can be max. 30 mA, but only in case of appliances with a high system-related leakage (e.g. in case of Y-capacitors).

### 5.4.2 Test voltages for DC testing (testing with DC current, approx. 5 HZ)

Test time 1 sec.

	Protection class I	Protection class II	Protection class III
<b>EN 50106</b>	1500 V	3750 V	600 V <sup>*3</sup>
<b>EN 60204</b>	1000 V	Not applicable	Not applicable
<b>UL / CSA</b>	$(1200 + 2.4 \times U_{\text{rated}}) \times 1,414$ <sup>*2</sup>	$1200 + 2.4 \times U_{\text{rated}}$ <sup>x</sup> $1,414$ <sup>*2</sup>	Not applicable
<b>Kärcher commitment<sup>*1</sup></b>	<b>2250 V</b> <sup>*2</sup>	<b>3750 V</b> <sup>*2</sup>	<b>No testing</b> <sup>*3</sup>

<sup>\*1</sup> to avoid failures during switching to a different voltage, Kärcher is testing with a standardized test voltage (2250 V DC for SK I, 3750 V DC for SKII), which covers all requirements described, besides exceptions <sup>\*2</sup> and <sup>\*3</sup>.

<sup>\*2</sup> the following is applicable for devices that are to be tested according to UL / CSA:

- $U_{\text{rated}} < 125 \text{ V}$ : Uniform testing with  $U = 2250 \text{ V}$  DC at protection class I.
- $U_{\text{rated}} > 125 \text{ V}$ : DC testing with  $U = (1200 + 2.4 \times U_{\text{rated}}) \times 1,414$ . Test voltage at least 2250 V DC at protection class I and 3750 V DC at protection class II.
- Body-held devices (e.g. back cleaner) are tested with 4250 V DC.

<sup>\*3</sup> It is necessary to conduct HV testing if  $U > 42 \text{ V}$  (or 48 V in case of floor cleaners).

### The tripping current should not exceed 5mA.

The tripping current can be max. 30 mA, but only in case of appliances with a high system-related leakage (e.g. in case of Y-capacitors).

### 5.4.3 High voltage thermal test

In devices equipped with a GFCI switch (with low-voltage trigger); the switch cannot be activated in a potential-free state. A so-called thermal test is conducted to include the electrical circuits behind the switch in the high voltage test. The high voltage is overlaid on the normal operating voltage of e.g. 230 Volts when the appliance is in operation. This means – the potential at L as well as N is increased respectively to say 1500 Volt (as compared to PE).

Attention: The GFCI switch may get destroyed if it is operated beyond its specified limits (e.g. with 230 Volts instead of 110 Volts).

### 5.4.4 HV test on electrical motors

Section 8 of EN 60034 is specifically applicable to the testing of electrical motors. Based on this standard, we have defined the following values for testing at Kärcher:

- Motors with a rated voltage of 250 V and a rated power of  $< 5 \text{ kW}$  will be tested with 1800 V for 1 sec.

*ACHTUNG! Ein Ausdruck dient nur zur Information! Die aktuelle Version ist im Kärcher-Inside hinterlegt.*

Ersetzt Ausgabe vom:	2014-07-18	Erstellt:	OQM / Elliott	Freigabe:	OQM / Stütz
Ausgabedatum:	2018-02-15	Geprüft:	OQD-L / OQM	Seite 7 von 16	

	<h1>IM-Procedure</h1>	
	<h2>Electrical Safety Testing</h2>	<b>06-B07e</b>

- For motors with a rated voltage > 250 V to 400 V and/or a rated power of > 5kW until 200 kW the testing time will be increased to 5 sec.

Testing should only be done once on new appliances. If a repeating test is necessary, the test voltage has to be reduced to 80% of the above value.

### 5.4.5 High voltage test on battery chargers

Battery chargers are subjected to an additional test for proof voltage between the input and output circuits. The test voltage is 2500 V AC or 3750V DC. A disruptive discharge shall not occur. In general, the test has to be conducted by the manufacturer of the charger.

If Kärcher makes any modifications to the charger, a repeating of this test is necessary.

Additionally, this test has to be done whenever the battery charger is manufactured by Kärcher (for e.g. RC 3000).

### 5.4.6 HV testing on equipment with PRCD-K protect switch

With the low-voltage trigger and the varistor in the protective conductor path (see 2.2.1) a HV test with a power plug is not possible. Even a HV thermal test is, because of the high resistance protective conductor circuit, not possible.

With a bypassed protective conductor (see 2.2.1) a HV thermal test can be conducted on a PRCD-K protect switch, as described in 2.4.3.

As alternative, a not bypassed protective conductor in the PRCD-K protect switch can be tested in 2 stages.

Thereby is,

- a.) The HV test conducted between power switch and connector- input at the PRCD-K protect switch (IN), as described in 2.4
- b.) Then test between input appliance (out clip PRCD-K switch) and appliance, as described above.

## 6 Layout of the test benches

### 6.1 Area of application

EN 50191 provides details about the set up and operation of stationary and mobile electrical testing units.

It is not necessary to conform to this standard if a contact with parts under potential is not dangerous.

This is assured if:

- The voltage at frequencies up to 500 Hz with a maximum of 25 V AC or 60 V DC (small protective voltage).
- The voltage at frequencies up to 500 Hz above 25 V AC or 60 V DC the current caused by it through an induction-free resistance of 2kΩ is not higher than 3mA AC respectively 12 mA DC.

The requirements of EN 50191 have to be met if the test bench is not only used for high voltage testing but also for functional testing. In this case, the fault current limit (3 respectively 12 mA) is in-active. Furthermore, the supply voltage is e.g. 230 V and not < 25 respectively 60 V.

<i>ACHTUNG! Ein Ausdruck dient nur zur Information! Die aktuelle Version ist im Kärcher-Inside hinterlegt.</i>		
Ersetzt Ausgabe vom:	2014-07-18	Erstellt: OQM / Elliott
Ausgabedatum:	2018-02-15	Freigabe: OQM / Stütz
		Seite 8 von 16

	<h1>IM-Procedure</h1>	
	<h2>Electrical Safety Testing</h2>	<b>06-B07e</b>

## 6.2 Layout of a test bench (according to EN 50191)

The test unit has to be designed in such a way that it ensures the protection against direct contact through insulation of active parts, lids, covers, barriers or safe distances.

A safe distance is ensured, when the tester cannot reach the prohibited zone either physically or even with the help of objects. Protection can also be ensured by using a two-hand switch or two safety-testing probes.

### 6.2.1 Cordoning off the test area

Test areas must be cordoned off from working places and traffic routes. The cordoning off must be designed in such a way that

- No other person than the tester can enter the test area.
- Persons who are located outside the limits cannot reach the operating elements of the unit.
- Tester and test piece must have proper ground insulation.

### 6.2.2 Signal lamps and markings

- Test units must have fittings to indicate the switching status of the unit, for e.g. signal lamps.
- Testing units and test areas must be marked clearly and visibly with warning signs.

### 6.2.3 Emergency-stop mechanism

- Test units must be equipped with emergency stop mechanism so that all electrical energies, which can be dangerous, can be switched off.
- It is necessary to provide an adequate number of emergency stop facilities within and outside the test area, depending on its size, and the visibility of the arrangement.

## 6.3 Operating test benches

### 6.3.1 General

- Test benches must only be operated under the management and supervision of a trained electronic-technician. This is not applicable to test benches with compulsory anti-contact guards.
- Operating instructions have to be available for operating the test units. These have to contain all important details necessary for safe operation.
- The test benches must be visually inspected for external damages or defects before using them.
- Test benches should not be operated if damages or defects, which can be hazardous, occur.
- Maintenance and repair of test benches must only be done by electronic-technicians.

### 6.3.2 Personnel

- Only electronic-technicians or persons trained in electrical work must be allowed to work on the test benches.

<i>ACHTUNG! Ein Ausdruck dient nur zur Information! Die aktuelle Version ist im Kärcher-Inside hinterlegt.</i>		
Ersetzt Ausgabe vom:	2014-07-18	Erstellt: OQM / Elliott
Ausgabedatum:	2018-02-15	Freigabe: OQM / Stütz
		Seite 9 von 16

- All involved persons must be trained in safety requirements, safety regulations and operating instructions and regulations that are to be applied in the course of their work.
- This training is to be repeated annually.
- The staff must be instructed to strictly conform to these requirements, regulations and instructions.
- Training documents and reports must be documented.

## **7 Test procedures**

### **7.1 Daily inspection of test units**

The testing unit must be inspected every day before starting testing, during change of shifts or before use to ensure that it is **functioning** correctly and there are no **externally visible damages**.

The functional testing of the units is done with the help of a dummy which can be used to simulate a “good test” as well as a “bad test” (by changing the dummy settings) for all the individual tests (HV, Iso, PE) which have to be conducted.

The swipe-out function in simulated faults has to be checked also for automatic lines. There must be a test instruction available for using the dummy.

The inspection of the unit has to be confirmed and documented with date and signature of an authorised person. A list of “daily inspection routine” has to be fixed at each test bench. The supervisor is responsible for ensuring correct execution and documentation of the daily inspection activities.

**Caution! Faults detected during inspection are to be immediately reported to the superiors. Safety inspection must NOT be done on defective units.**

A manual dummy inspection can be omitted in case of test benches with automatic inspection through a good/bad testing (resistance simulation conducted by the test bench) under the following circumstances:

- Inspection is being carried out at least once daily.
- Inspection incl. test results are being documented.
- The dummy function is being checked during annual calibration of the unit.

### **7.2 Appliance testing**

#### **7.2.1 Preparation**

- Close the testing room respectively cordon it off with a chain.
- Ensure that only one person is present in the testing room.
- Insert the appliance plug in the switch-board of the test unit or clamp the open ends.
- Switch on the main switch of the test piece.
- Activate contactors (mechanically).
- Turn on the main switch of the test unit.

#### **7.2.2 Conducting the protective conductor and insulation tests according to EN 60204**

- Set the limit value for the protective conductor resistance for the tested appliance according to the list (depending on the length and wire cross-section of the connecting cable). Select the respective testing plan for automatic testing systems.

*ACHTUNG! Ein Ausdruck dient nur zur Information! Die aktuelle Version ist im Kärcher-Inside hinterlegt.*

Ersetzt Ausgabe vom:	2014-07-18	Erstellt:	OQM / Elliott	Freigabe:	OQM / Stütz
Ausgabedatum:	2018-02-15	Geprüft:	OQD-L / OQM	Seite 10 von 16	

- Check the limit value for insulation resistance (1M $\Omega$ ).
- Check whether the appliance switch and all protectors have been activated. Be careful with GFCI switches with low-voltage trigger; refer 2.4.3.
- Scan the points mentioned in the test instruction for this appliance using the PE test probe.
- The PE testing device must show a good signal (e.g. green lamp) for each scanned point; this means that the measured value lies below the set limit value.

It needs to be noted that insulation testing is normally conducted using a sequence operation of the PE test (e.g. Elabo test units). This means that insulation testing is started using the probe only if the PE test has been OK.

- The measured value for insulation must lie above the set limit value.
- Insulation measuring devices must show good results (for e.g. glowing green lamp).
- Check for good message for both the tests (normally a continuous sound).
- If no good message is received, then you will see a PE or insulation error (for e.g. red lamp glows).
- Cancel the test if there is an error and send the appliance for repair.

### **7.2.3 Conducting protective conductor test according to EN 50106**

- It is not necessary to measure insulation resistance.
- Check the set limit value for the protective conductor resistance (it must be equal to 0.2  $\Omega$  or 0.1 $\Omega$  + resistance of the supply cable).
- Scan the points mentioned in the test instruction for the appliance using the PE test probe.
- There must be a “good” indication for each scanned point (e.g. green lamp); this means that the measured value lies below the set limit value.
- Check for good message (normally a continuous sound).
- If there is no “good” message, it means the protective conductor system has an error.
- Cancel the test if there is an error and send the appliance for repair.

### **7.2.4 Conducting high voltage test**

- Check whether the appliance switch has been turned on and all protectors have been activated. Be careful with GFCI switches with low-voltage trigger; refer 4.2.2.
- Check testing time (normally 1 sec) and test voltage.
- Start high voltage test.
- The voltage display must indicate the set value.
- Current indicator must show a value less than 5mA; in exceptional cases it can also be 30 mA, refer point 2.4.2.
- Faults are audible (acoustic interval signal) and visible; these need to be actively reset.

*ACHTUNG! Ein Ausdruck dient nur zur Information! Die aktuelle Version ist im Kärcher-Inside hinterlegt.*

Ersetzt Ausgabe vom:	2014-07-18	Erstellt:	OQM / Elliott	Freigabe:	OQM / Stütz
Ausgabedatum:	2018-02-15	Geprüft:	OQD-L / OQM	Seite 11 von 16	

	<h1>IM-Procedure</h1>	
	<h2>Electrical Safety Testing</h2>	<b>06-B07e</b>

- There will be an acoustic as well as visual warning when there is testing time shortfall or if the contact control is triggered; these will then have to be reset. In such cases, the test must be repeated.
- Faulty appliances must be forwarded for repairs.

### 7.2.5 Conducting high voltage tests on switch-boards

The contact control of the testing unit cannot check all electrical circuits of the switch-boards. Hence, it is necessary to test the safety of switch-boards according to a test plan. This will describe the protectors which have to be activated, the points where high voltage has to be applied, the points which has to be scanned by the PE probe and also perhaps the electronic parts that need to be short-circuited before conducting the tests. The tester must maintain detailed documentation of the individual steps.

## 8 Marking tested devices

VDE or ISO 9000 prescribes that the good respectively bad appliances have to be marked distinctly and segregated. Hence we have finalized the following marking for each appliance that passes the high voltage test (HV- good):

### 8.1 Appliances with test results “HV good”

#### Manual test benches

Either a sticker (as shown in the figure) or the type plate of the appliance –anyway affixed on the appliance after the HV-good testing- has to be used at all manual test benches to signify whether the appliance has passed the safety tests. The test instruction shall specify the place where this sticker has to be placed.



#### Automatic test benches

Markings can be done in different ways in automatic HV test benches. (Barcode with personal no., autom. stamp, type plate, etc.). The exact marking must be defined in the test specification.

### 8.2 Appliances with test results “HV poor”

Faulty appliances have to be marked with a sign “BLOCKED” (in German ‘Geperrt’) as shown in the adjacent figure. Exception: Lines where the faulty appliances are automatically moved to the repairs station.

After repairs, the appliances are again subjected to complete electrical safety testing.

<i>ACHTUNG! Ein Ausdruck dient nur zur Information! Die aktuelle Version ist im Kärcher-Inside hinterlegt.</i>		
Ersetzt Ausgabe vom:	2014-07-18	Erstellt: OQM / Elliott
Ausgabedatum:	2018-02-15	Geprüft: OQD-L / OQM
		Freigabe: OQM / Stütz
		Seite 12 von 16

	<h1>IM-Procedure</h1>	
	<h2>Electrical Safety Testing</h2>	<b>06-B07e</b>

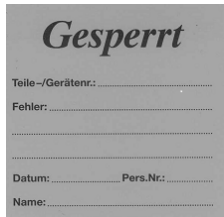

### 8.2.1 Defective appliances during functional testing

If changes are done to the electrical equipment of an appliance during repairs for the “functional testing failed” appliances (e.g. parts are clamped and reconnected), then the “HV good” sticker has to be removed. Complete electrical safety testing has to be conducted once again after repairs.

## 9 Calibration

### 9.1 Test unit

The test units are maintained along with other measuring equipment. They have to be calibrated at least annually. Calibration includes the entire system (high voltage, insulation, protective conductor). To keep the calibration effort to the minimum, Kärcher has approved the following manufacturers for testing systems:

Companies Stahl, Elabo, Gossen Metrawatt, Risatti.

The use of testing systems of other manufacturers is only permitted in justified exceptional cases and only with prior approval from CQM-L.

### 9.2 Test dummy

The dummies for daily functional testing of the units have to be maintained also as part of the measuring equipment and have to be inspected at least once every two years. A sticker with the next inspection date has to be placed.

## 10 Training for safety inspectors

Electrical safety testing may only be conducted by trained persons or qualified Electronic-technicians.

The training must include at least the following points:

- Hazards of electricity
- First aid in the event of electrical accidents
- Explanation of Ohm’s law
- Introduction to EN standards (EN 50 106 and perhaps EN 60 204)
- Different safety classes (SK I to SK III)
- Layout of a test bench (EN 50191)
- Operation of the test unit and the dummies for day-to-day testing
- Daily inspection
- Procedure for conducting electrical safety tests
- Awareness about conscientious conducting of safety tests

<i>ACHTUNG! Ein Ausdruck dient nur zur Information! Die aktuelle Version ist im Kärcher-Inside hinterlegt.</i>		
Ersetzt Ausgabe vom:	2014-07-18	Erstellt: OQM / Elliott
Ausgabedatum:	2018-02-15	Freigabe: OQM / Stütz
		Seite 13 von 16

This training has to be repeated annually and conducted as required (e.g. new employees). Training has to be conducted by an authorised employee (qualified electronic-technician) of the respective plant. Each participant must be given handouts about (initial) training on the subject "Electrical Safety Training". Training has to be documented with a list with name, employee number, date as well as signature of the participant and the trainer. This list must be maintained by the employee of the respective plant who conducts this training and must also be displayed on the test benches. The respective superiors are responsible for nominating the employees respectively for scheduling of these training sessions.

## 11 Process description

### 11.1 Testing flow

1. Tester approved?	
	Testing with list of self-testers No → continue with 2. ↓ Yes → continue with 3.
2. Training electrical safety testing	
↓	... and add to self-tester list
3. Daily inspection of unit	
↓	...with dummy; follow operating instructions for dummy
4. Unit ok?	
↓	No → continue with 5. Yes → continue with 7.
5. Message to superiors.	
↓	
6. Unit blocked	
	Repair and continue with 4.
7. Confirm inspection	
↓	...in list "daily check"
8. Safety testing on device	
↓	
9. Set marginal values in test equipment	
↓	... with setting sheet and test specifications of the device
10. Conduct PE-test	
↓	
11. PE ok?	
↓	No → continue with 12. Yes → continue with 15.

*ACHTUNG! Ein Ausdruck dient nur zur Information! Die aktuelle Version ist im Kärcher-Inside hinterlegt.*

Ersetzt Ausgabe vom:	2014-07-18	Erstellt:	OQM / Elliott	Freigabe:	OQM / Stütz
Ausgabedatum:	2018-02-15	Geprüft:	OQD-L / OQM	Seite 14 von 16	

## 12. Cancel test

↓

## 13. Mark device

...according test operation instruction of the device

- as "HV poor"

## 14. Device for repairs

↓ Repair and continue with 8.

## 15. Isolations-Test started automatically

↓

## 16. Isolations-test ok

No → continue with 12.

↓ Yes → continue with 17.

## 17. Conduct HV-test

↓

## 18. HV-test ok?

No → continue with 12.

↓ Yes → continue with 19.

## 19. Mark device

.. according test operation instruction of the device

↓ Labeling with specification plate, label "HV tested", bar code or automatical stamp.

## 20. Regularly control

↓ .. through production control inspection, which control the list of daily inspections as well.

## 21. Function test

**11.2 Flow when errors at function test bench**

## 1. Function test

↓

## 2. Function test ok

Yes → continue with production process

↓ No → continue with 3.

## 3. Device for repair

↓

*ACHTUNG! Ein Ausdruck dient nur zur Information! Die aktuelle Version ist im Kärcher-Inside hinterlegt.*

Ersetzt Ausgabe vom: 2014-07-18

Erstellt: OQM / Elliott

Freigabe: OQM / Stütz

Ausgabedatum: 2018-02-15

Geprüft: OQD-L / OQM

Seite 15 von 16

4. Intervention in E-equipment necessary?	
↓	No → Repair → continue with 1. Yes → continue with 5.
5. Remove label "HV good"	
↓	Very important !!!
6. Repair device	
↓	
7. Electrical safety test	
	When ok continue with 1.

**12 Reference**

- DIN EN ISO 9001:2015 chapter 8.6 "Release of products and services" and chapter 8.7 "Control of nonconforming outputs"

**13 Modifications**

15.02.2018: siehe Kapitel 1 "Allgemeines"

*ACHTUNG! Ein Ausdruck dient nur zur Information! Die aktuelle Version ist im Kärcher-Inside hinterlegt.*

Ersetzt Ausgabe vom: 2014-07-18	Erstellt: OQM / Elliott	Freigabe: OQM / Stütz
Ausgabedatum: 2018-02-15	Geprüft: OQD-L / OQM	Seite 16 von 16